



STEERING UNITS



OSPB, OSPC, OSPF,
OSPD, OSPQ, OSPL
Load Sensing
Steering Units

OLS Priority Valves

OSQ Flow Amplifiers

Technical
Information



Load Sensing Steering Units, Priority Valves and Flow Amplifiers Technical Information

A Wide Range of Steering Components

Revision History

Table of Revisions

Date	Page	Changed	Rev
Nov 2009	Many	Steering column deleted	BA
Sep 2010	88	New back cover	BB
Feb 2011	4-5, 13	Typos	BC
Jun 2011	33	Flow range	BD
Feb 2012	80	Max pressure options changed	BE

A Wide Range of Steering Components



F500 026

Sauer-Danfoss is the largest producer in the world of steering components for hydrostatic steering systems on off-road vehicles. Sauer-Danfoss offer steering solutions both at component and system levels. Our product range makes it possible to cover applications of all types - ranging from ordinary 2-wheel steering (also known as Ackermann steering) to articulated steering, complicated 4-wheel steering, automatic steering (e.g. by sensor) and remote controlled steering via satellite. We can offer more than 1500 different steering units and 250 different priority valves categorized in types, variants and sizes.

T301033

© 2012 Sauer-Danfoss. All rights reserved.
Sauer-Danfoss accepts no responsibility for possible errors in catalogs, brochures and other printed material. Sauer-Danfoss reserves the right to alter its products without prior notice. This also applies to products already ordered provided that such alterations can be made without affecting agreed specifications. All trademarks in this material are properties of their respective owners. Sauer-Danfoss, the Sauer-Danfoss logotype, the Sauer-Danfoss S-icon, PLUS+1™, What really matters is inside® and Know-How in Motion™ are trademarks of the Sauer-Danfoss Group.

Frontpage: F300 611, F300 612, F300 615, F300 617, F300 620, F300 622, F301 256, F301 470, F300 601. Drawing 151-577



A Wide Range of Steering Components

A Wide Range of Steering Components (continued)

For hydrostatic steering systems Sauer-Danfoss offers:

- Mini steering units with displacements from 32 to 100 cm³/rev [1.95 to 6.10 in³/rev], flow up to 20 l/min [5.28 US gal/min], steering pressure up to 125 bar [1813 psi].
- Steering units with displacements from 40 to 1200 cm³/rev [2.44 to 73.2 in³/rev], flow up to 100 l/min [26.4 US gal/min], steering pressure up to 240 bar [3481 psi].
- Priority valves for rated flows at 40, 80, 120, 160 and 320 l/min [10.6, 21.1, 31.7, 42.3 and 84.5 US gal/min], pressure up to 350 bar [5076 psi].
- Pilot operated flow-amplifiers with amplification factors of 4, 5, 8, 10 or 20 for rated oil flows of 240 and 400 l/min [63.4 and 105.7 US gal/min], steering pressure up to 210 bar [3045 psi].
- Pilot operated steering valve with steering flow up to 100 l/min [26.4 US gal/min], steering pressure up to 250 bar [3625 psi] and with integrated priority valve for pump flow up to 120 l/min [31.7 US gal/min].

For electro hydraulic steering systems Sauer-Danfoss offers:

- Pilot operated steering valves (pilot operated by hydrostatic steering unit or by electrical signal) with steering flows up to 100 l/min [26.4 US gal/min], steering pressure up to 250 bar [3625 psi].
- Steering units with integrated electrical operated steering valve with steering flow up to 50 l/min [13.2 US gal/min], steering pressure up to 210 bar [3045 psi].
- Electrical operated steering valves with steering flow up to 40 l/min [10.57 US gal/min], steering pressure up to 210 bar [3045 psi].

Characteristic features for steering units:

- Low steering torque: From 0.5 Nm to 3 Nm in normal steering situations
- Low noise level
- Low pressure drop
- Many types available: Open center None reaction, Open center Reaction, Closed center None reaction, Load Sensing, Load Sensing Reaction
- One or more built-in valve functions: relief valve, shock valves, suction valves, none return valve in P-line and in LS-line
- Optional port connections (according to ISO, SAE or DIN standards)

Characteristic features for electrohydraulic steering system:

- Electrohydraulic steering valve EHPS: High steering pressure requiring smaller cylinders and flow
- EHPS: Low pilot pressure and flow giving extremely low noise in the cabin
- EHPS: The possibility of manual steering even on very heavy vehicles
- EHPS can be combined with Sauer-Danfoss PVG 32 proportional valve
- Minimization of side acceleration with articulated steering
- Possibility of GPS-, row sensor-, joy stick- steering and variable steering ratio

T301034

Conversion Factors

1 N·m =	[8.851 lbf·in]	1 cm ³ =	[0.061 in ³]
1 N =	[0.2248 lbf]	1 l =	[0.264 US gal]
1 bar =	[14.50 psi]	°F =	[1.8°C + 32]
1 mm =	[0.0394 in]		

T301035



Contents and Technical Literature Survey

Contents

A Wide Range of Steering Components	2
Conversion Factors.....	3
Survey of Literature with Technical Data on Sauer-Danfoss Steering Components.....	6
LS Steering Units OSPB, OSPC, OSPF, OSPD, OSPQ, OSPL	7
Versions.....	7
Code Numbers and Weights	13
OSPB load sensing static non-reaction steering units.....	13
OSPB load sensing dynamic non-reaction steering units.....	14
OSPC load sensing static non-reaction steering unit	15
OSPC load sensing dynamic non-reaction steering units.....	16
OSPC load sensing dynamic reaction steering units	17
OSPF load sensing dynamic non-reaction steering units	18
OSPD load sensing non-reaction steering units.....	19
OSPQ load sensing dynamic non-reaction steering units	20
OSPL load sensing static non-reaction steering units.....	21
OSPL load sensing dynamic non-reaction steering units	21
OSPBX and OSPLX load sensing static steering units for OSQ static	23
OSPCX load sensing dynamic steering units for OSQ dynamic.....	23
Specification Table for Non Catalogue Numbers of LS Steering Units.....	24
Port Thread Versions and Valve Combinations	26
Technical Data	29
Displacement, flow and pressure: OSPB LS, OSPC LS, OSPC LSR.....	29
Displacement, flow and pressure: OSPF LS	30
Displacement, Flow and Pressure: OSPD LS, OSPQ LS.....	31
Displacement, flow and pressure: OSPL LS, OSPBX LS, OSPCX LS, OSPLX LS	32
Valve functions in OSPC, OSPF, OSPD, OSPQ and OSPL LS steering units.....	33
Port Thread Versions.....	35
Dimensions.....	36
OSPB LS for OLS, OSPBX LS for OSQ.....	36
OSPC LS/LSR and OSPF LS for OLS, OSPCX LS for OSQ	37
OSPD LS/LSR for OLS	38
OSPQ LS/LSR for OLS	39
OSPL LS for OLS and OSPLX LS for OSQ.....	40
OSPL 1200 LS for OLS.....	41
Valve Block OVPL	42
Versions.....	42
Code Numbers and Weights	42
Technical Data	46
Installation	48
Dimensions.....	49
Angle Block OVR	51
Version.....	51
Code Numbers and Weight	51
Installation	51
Dimensions.....	52

Contents and Technical Literature Survey

Contents

Priority Valves OLSA and OLS	53
Versions.....	53
System Sizing	56
Code Numbers and Weights	56
OLS/OLSA static priority valves for load sensing static steering units	56
OLS/OLSA static priority valves for load sensing statics steering units	57
OLS/OLSA dynamic priority valves for load sensing dynamic steering units.....	57
OLS/OLSA dynamic priority valves for load sensing dynamic steering units.....	58
OLS dynamic priority valves for OSPF LS dynamic steering units.....	59
Specification Table for Non Catalogue Numbers of Sauer-Danfoss Priority Valves.....	61
Technical Data	62
Max. Pressure on Connections	62
Pressure Drop in Priority Valves.....	63
Dimensions.....	70
OLSA.....	70
OLS 40, OLS 80.....	71
OLS 120.....	72
OLS 160.....	73
OLSP 80.....	74
OLS 320 in-line.....	75
Flow Amplifiers OSQA, OSQB and OSQB/OLSQ.....	76
Versions.....	76
Code Numbers and Weights	78
Specification Table for Non Catalogue Numbers of Sauer-Danfoss Flow Amplifiers	79
Technical Data	80
Flow and Pressure.....	80
Total Displacement of Steering System.....	80
Installation.....	80
Valve functions in the flow amplifiers	81
Dimensions.....	85
OSQA.....	85
OSQB	86
OSQB with OLSQ	87

Contents and Technical Literature Survey

Survey of Literature with Technical Data on Sauer-Danfoss Steering Components

Detailed data on all Sauer-Danfoss steering components and accessories can be found in our steering component catalogues, which is divided in to 6 individual sub catalogues:

- | | |
|--|---|
| • General information | Steering components |
| • Technical data on mini steering units | OSPM |
| • Technical data on open center, and closed center steering units | OSPB, OSPC, and OSPD |
| • Technical data on load sensing steering units, priority valves and flow amplifiers | OSPB, OSPC, OSPF, OSPD, OSPQ, OSPL, OSPBX, OSPLX, OVPL, OLS and OSQ |
| • Technical data on hydraulic and electro-hydraulic pilot operated steering valves, electrical actuation modules and appropriate steering units. | EHPS, EHPS w. OLS 320, PVE for EHPS and OSPCX |
| • Technical data on combined steering unit/electro hydraulic steering valves and steering wheel sensors | OSPE and SASA |

The most important data on all Sauer-Danfoss steering components is highlighted in a general survey brochure.

For technical information on individual variants, please contact the Sauer-Danfoss Sales Organization.

T301036

LS Steering Units OSPB, OSPC, OSPF, OSPD, OSPQ, OSPL

Versions

Load sensing

In load sensing steering systems both the steering system and the working hydraulics can be supplied with oil from the same pump, using a load sensing pump, also delivers the potential for energy saving.

Load sensing steering units have an extra connection for load sensing (LS), so that a load pressure signal can be directed via the steering unit to a Sauer-Danfoss priority valve and/or an LS pump. The load sensing signal controls the oil flow from the priority valve (and/or the LS pump) to the steering unit. The LS connection is open to tank when the steering unit is in the neutral position.

Load sensing static

Load sensing static steering units require load sensing static priority valves and/or load sensing static variable displacement pumps. Load sensing static steering systems have no oil flow in the LS connection when the steering unit is in neutral position.

Load sensing dynamic

Load sensing dynamic steering units require load sensing dynamic priority valves and/or load sensing dynamic variable displacement pumps. Load sensing dynamic steering systems have a constant oil flow in the LS connection in the direction of the steering unit even when the steering unit is in neutral position.

Reaction

With reaction steering units any external forces acting on the steered wheels result in a corresponding movement of the steering wheel when the driver is not steering the vehicle.

Non-reaction

With non-reaction steering units there is no corresponding movement of the steering wheel when the driver is not steering the vehicle

OSPB LS: Steering unit with no valve functions

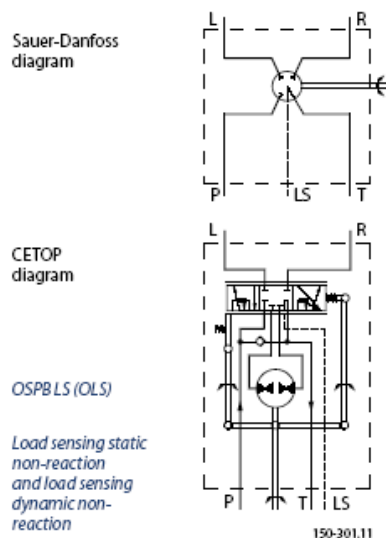

F300614



LS Steering Units OSPB, OSPC, OSPF, OSPD, OSPQ, OSPL

Versions



F300614

OSPC LS: Steering unit load sensing with integrated valve functions for in line priority valve OLS

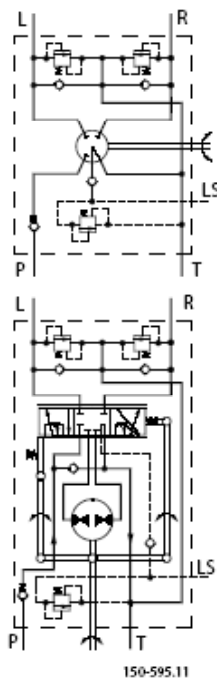

*OSPC LS (OLS)
Load sensing dynamic non-reaction*



F300724

OSPC LS: Steering unit load sensing with integrated valve functions for flange on priority valve OLSA

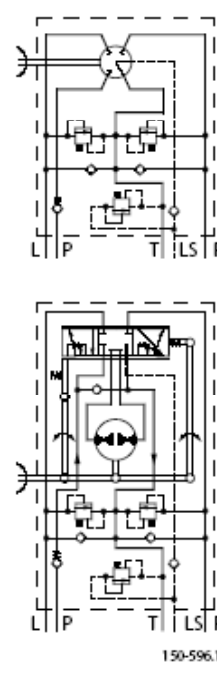

*OSPC LS (OLSA)
Load sensing dynamic non-reaction*



LS Steering Units OSPB, OSPC, OSPF, OSPD, OSPQ, OSPL

Versions



F300617

OSPC LSR: Steering unit load sensing dynamic with integrated valve functions

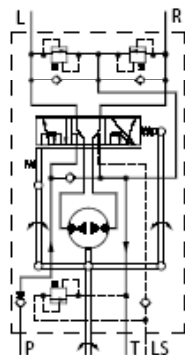
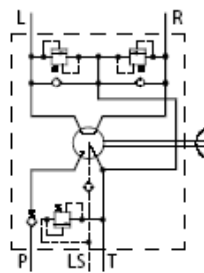

150-598.11

*OSPC LSR (OLS)
Load sensing dynamic reaction*

OSPF LS : Steering unit full drain load sensing dynamic and with integrated valve functions

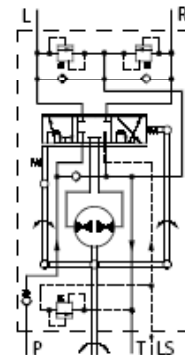
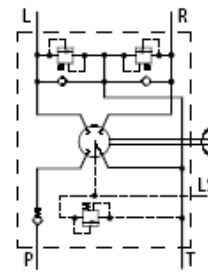

150-597.11

*OSPF LS (OLS)
Load sensing dynamic non-reaction*

LS Steering Units OSPB, OSPC, OSPF, OSPD, OSPQ, OSPL

Version

OSPD LS: Steering unit load sensing dynamic with 2 rotary meters and with integrated valve functions

The OSPD has 2 rotary meters (gear wheel sets). Should the pump supply be lost, only one rotary meter is active for emergency steering. In normal steering situations both rotary meters are active.

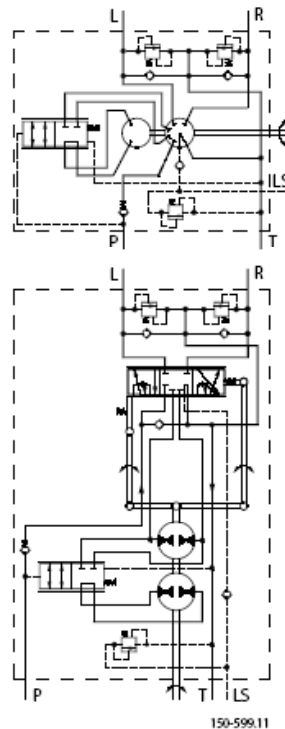

OSPD LS (OLS)
Load sensing dynamic non-reaction

OSPQ LS: Steering unit load sensing dynamic with flow amplification and with integrated valve functions

The OSPQ has incorporated amplification valve. Should pump supply fail or the steering wheel speed be less than approximate 10 rev/min only the rotary meter determines the displacement. In normal steering situations or at higher steering wheel speed, oil is also led to the steering cylinder via the built in amplification valve.

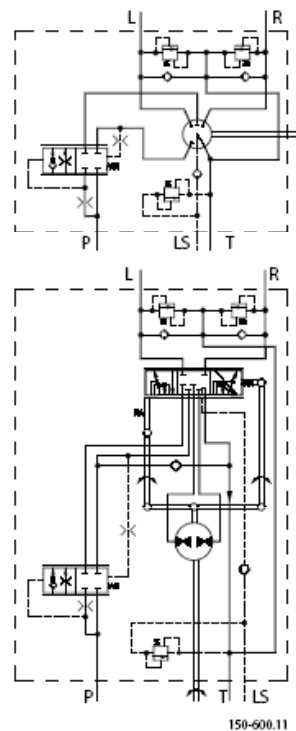

OSPQ LS (OLS)
Load sensing dynamic non-reaction

LS Steering Units OSPB, OSPC, OSPF, OSPD, OSPQ, OSPL

Version

OSPL LS:

Steering unit load sensing for high steering flow, displacement larger than 500 cm³/rev [30.5 in³/rev].



F300611

*OSPL LS (OLS)
Load sensing static
non-reaction*

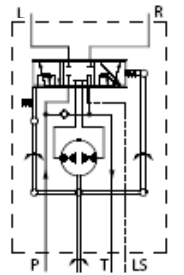
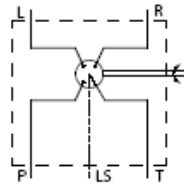

150-301.11

*OSPL LS (OLS)
Load sensing dynamic
non-reaction*

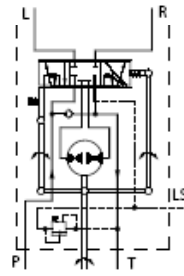
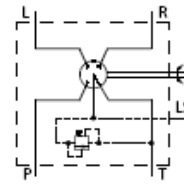

150-601.10

*OSPL 1200 (OLS) Load
sensing dynamic non-
reaction*

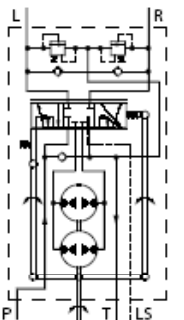
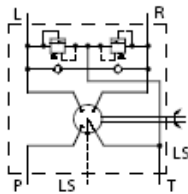

150-613.10



F301082



LS Steering Units OSPB, OSPC, OSPF, OSPD, OSPQ, OSPL

Versions

OSPBX LS, OSPCX LS and OSPLX LS: Steering units load sensing for flow amplifiers.

OSPBX LS, OSPCX LS and OSPX LS are load sensing steering units with the L and the R connections open to tank when in neutral position. OSPBX LS, OSPCX LS and OSPX LS can only be used with Sauer-Danfoss flow-amplifiers OSQA or OSQB. OSPBX LS, OSPCX LS and OSPX LS steering units must not be connected directly to the steering cylinder. OSPCX LS is for OSQ dynamic without pilot pressure relief valve.



.J00614

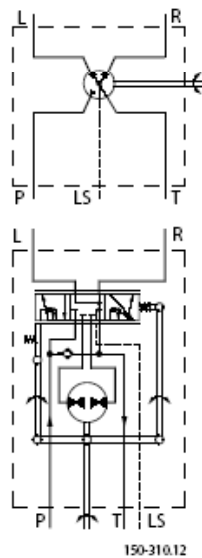

OSPBX LS, OSPLX LS
Load sensing static

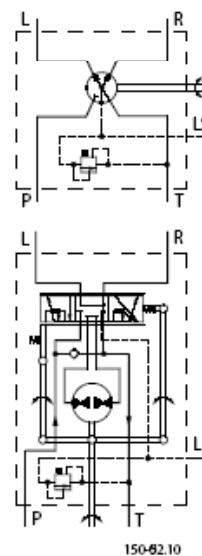

OSPCX LS
Load sensing dynamic

LS Steering Units OSPB, OSPC, OSPF, OSPD, OSPQ, OSPL

Code Numbers and Weights

OSPB load sensing static non-reaction steering units

OSPB LS Static steering units have no valve functions.

OSPB LS in the table below have all standard neutral setting springs, see page 24

Steering unit	Code Numbers		Weight kg [lb]
	Connections		
	European version for OLS G 1/2 G 1/4 - S**	US version for OLS 3/4-16 UNF - O* 7/16-20 UNF - O* + S**	
OSPB 50 LS	-	150G6085	5.2 [11.46]
OSPB 80 LS	-	150G6086	5.3 [11.68]
OSPB 100 LS	-	150G6087	5.4 [11.90]
OSPB 125 LS	-	150G6088	5.5 [12.13]
OSPB 160 LS	-	150G6089	5.6 [12.35]
OSPB 200 LS	150-0103	150G6090	5.8 [12.79]
OSPB 315 LS	150-0104	150-0116	6.2 [13.67]
OSPB 400 LS	150-0105	150-0117	7.0 [15.43]

O*: O-ring chamfer on port connections

S**: Spot face around port connection

Valve blocks OVP and OVR can be mounted on all of the OSPB steering units from the above table.

LS Steering Units OSPB, OSPC, OSPF, OSPD, OSPQ, OSPL

Code Numbers and Weights

OSPB load sensing dynamic non-reaction steering units

OSPB LS Dynamic steering units have no valve functions.

OSPB LS in the table below have all standard neutral setting springs, see page 24

Steering unit	Code Numbers	Weight kg [lb]
	Connections US version for OLS 3/4-16 UNF - O* 7/16-20 UNF - O* + S**	
OSPB 50 LS	150-8204	5.2 [11.46]
OSPB 80 LS	150-8205	5.3 [11.68]
OSPB 100 LS	150-8206	5.4 [11.90]
OSPB 125 LS	150-8207	5.5 [12.13]
OSPB 160 LS	150-8208	5.6 [12.35]
OSPB 200 LS	150-8209	5.8 [12.79]
OSPB 315 LS	150-8210	6.2 [13.67]
OSPB 400 LS	150-8211	7.0 [15.43]

O*: O-ring chamfer on port connections

S**: Spot face around port connection

Valve blocks OVP and OVR can be mounted on all of the OSPB steering units from the above table

LS Steering Units OSPB, OSPC, OSPF, OSPD, OSPQ, OSPL

Code Numbers and Weights

OSPC load sensing static non-reaction steering unit

OSPC LS Static steering units in the table below incorporate all the following valve functions:

- check valve in P-port
- pilot pressure relief valve
- shock valves
- suction valves

OSPC LS in the table below have all standard neutral setting springs, see page 24

Steering unit	Code numbers			Valve settings		Weight kg [lb]
	European for OLS G 1/2 G 1/4 - S**	European and US version for OLSA	US version for OLS 3/4-16 UNF - O* 7/16-20 UNF - O* + S**	Relief valve bar [psi]	Shock valve bar [psi]	
OSPC 80 LS	150-1230	150-1188	150-1222	170 [2465]	225 [3263]	5.3 [11.68]
OSPC 100 LS	150-1231	150-1189	150-1221			5.4 [11.90]
OSPC 125 LS	150-1232	150-1190	150-1220			5.5 [12.13]
OSPC 160 LS	150-1233	150-1191	150-1219			5.6 [12.35]
OSPC 200 LS	150-1234	150-1192	150-1218			5.8 [12.79]
OSPC 315 LS	150-1235	-	150G6091			6.2 [13.67]
OSPC 400 LS	150-1240	-	-			7.0 [15.43]

O*: O-ring chamfer on port connections

S**: Spot face around port connections

If you require other port connections, valve combinations and/or other valve settings or other displacements, please fill in the order form on page 24 and contact the Sauer-Danfoss Sales Organization.

LS Steering Units OSPB, OSPC, OSPF, OSPD, OSPQ, OSPL

Code Numbers and Weights

OSPC load sensing dynamic non-reaction steering units

OSPC LS Dynamic steering units in the table below incorporate all the following valve functions:

- check valve in P-port
- pilot pressure relief valve
- shock valves
- suction valves
- check valve in LS-line for all OSPC LS Dynamic up to and including 200 cm³/rev

OSPC LS in the table below have all standard neutral setting springs, see page 24

Steering unit	Code numbers			Valve settings		Weight kg [lb]
	Connections			Relief valve	Shock valve	
	European version for OLS G 1/2 - S** G 1/4 - S**	European and US version for OLSA	US version for OLS 3/4-16 UNF - O* 7/16-20 UNF - O*+S**	bar [psi]	bar [psi]	
OSPC 50 LS	150-8233	150-8222	150-8215	140 [2030]	200 [2900]	5.2 [11.46]
OSPC 80 LS	150-8234	150-8223	150-8216	170 [2465]	225 [3263]	5.3 [11.68]
OSPC 100 LS	150-8235	150-8224	150-8217			5.4 [11.90]
OSPC 125 LS	150-8236	150-8225	150-8218			5.5 [12.13]
OSPC 160 LS	150-8237	150-8226	150-8219			5.6 [12.35]
OSPC 200 LS	150-8238	150-8227	150-8220			5.8 [12.79]
OSPC 315 LS	150-8239	-	150-8221			6.2 [13.67]
OSPC 400 LS	150-8240	-	-			7.0 [15.43]

O*: O-ring chamfer on port connections

S**: Spot face around port connections

If you require other port connections, valve combinations and/or other valve settings or other displacements please fill in the order form on page 24 and contact the Sauer-Danfoss Sales Organization.

LS Steering Units OSPB, OSPC, OSPF, OSPD, OSPQ, OSPL

Code Numbers and Weights

OSPC load sensing dynamic reaction steering units

OSPC LSR Dynamic steering units in the table below incorporate all the following valve functions:

- check valve in P-port
- pilot pressure relief valve
- shock valves
- suction valves
- check valve in LS-line

OSPC LSR in the table below have all standard neutral setting springs, see page 24

Steering unit	Code numbers	Valve settings		Weight kg [lb]
	Connections European version for OLS G 1/2 - S** G 1/4 - S**	Relief valve bar [psi]	Shock valve bar [psi]	
OSPC 80 LSR	150-8241	170 [2465]	225 [3263]	5.3 [11.68]
OSPC 200 LSR	150-8242			5.8 [12.79]

O*: O-ring chamfer on port connections

S**: Spot face around port connections (can not be used in connection with OVR angular block)

If you require other port connections, valve combinations, valve settings and/or other displacements, please fill in the order form on page 24 and contact the Sauer-Danfoss Sales Organization.

LS Steering Units OSPB, OSPC, OSPF, OSPD, OSPQ, OSPL

Code Numbers and Weights

OSPF load sensing dynamic non-reaction steering units

OSPF LS Dynamic steering units in the table below incorporate all the following valve functions:

- check valve in P-port
- pilot pressure relief valve
- shock valves
- suction valves

OSPF LS in the table below have all soft neutral setting springs, see page 24

Steering unit	Code numbers	Valve settings		Weight kg [lb]
	Connections European version for OLS G 1/2 - S** G 1/4 - S**	Relief valve bar [psi]	Shock valve bar [psi]	
OSPF 80 LS	150G5079	170 [2465]	225 [3263]	5.3 [11.68]
OSPF 100 LS	150G5080			5.4 [11.90]
OSPF 125 LS	150G5081			5.5 [12.13]
OSPF 160 LS	150G5082			5.6 [12.35]
OSPF 200 LS	150G5083			5.8 [12.79]
OSPF 315 LS	150G5084			6.2 [13.67]
OSPF 400 LS	150G5085			7.0 [15.43]

O*: O-ring chamfer on port connections

S**: Spot face around port connections (can not be used in connection with OVR angular block)

If you require other port connections, valve combinations, valve settings and/or other displacements, please fill in the order form on page 24 and contact the Sauer-Danfoss Sales Organization.

LS Steering Units OSPB, OSPC, OSPF, OSPD, OSPQ, OSPL

Code Numbers and Weights

OSPD load sensing non-reaction steering units

OSPD LS Dynamic steering units in the table below incorporate all the following valve functions:

- check valve in P-port
- pilot pressure relief valve
- shock valves
- suction valves
- check valve in LS-line

OSPD LS in the table below have all standard neutral setting springs, see page 24

Steering unit	Code numbers	Valve settings		Weight kg [lb]
	Connections European version G 1/2 - S** G 1/4 - S**	Relief valve bar [psi]	Shock valve bar [psi]	
OSPD 70/230 LS	150G8112	170 [2465]	225 [3263]	7.7 [17.00]
OSPD 70/270 LS	150G8113			7.9 [17.41]
OSPD 70/385 LS	150G8114			8.4 [18.52]
OSPD 125/325 LS	150G8128			8.1 [12.79]
OSPD 125/440 LS	150G8129			8.6 [18.96]

S**: Spot face around port connections (can not be used in connection with OVR angular block)

If you require other port connections, valve combinations, valve settings and/or other displacements, please fill in the order form on page 24 and contact the Sauer-Danfoss Sales Organization.

LS Steering Units OSPB, OSPC, OSPF, OSPD, OSPQ, OSPL

Code Numbers and Weights

OSPQ load sensing dynamic non-reaction steering units

OSPQ LS Dynamic steering units in the table below incorporate all the following valve functions:

- check valve in amplification valve, act as check valve in P-port
- pilot pressure relief valve
- shock valves
- suction valves
- check valve in LS-line

OSPQ LS in the table below have all standard neutral setting springs, see page 24

Steering unit	Code numbers	Valve settings		Weight kg [lb]
	Connections European version M 18 x 1.5 - O* + S** M 12 x 1.5 - O* + S**	Relief valve bar [psi]	Shock valve bar [psi]	
OSPQ 80/125 LS	150G8012	170 [2465]	225 [3263]	5.3 [11.68]
OSPQ 125/250 LS	150G8011			5.5 [12.79]
OSPQ 160/320 LS	150G8030			5.6 [12.35]

O*: O-ring chamfer on port connections

S**: Spot face around port connections (can not be used in connection with OVR angular block)

If you require other valve combinations, valve settings and/or other displacements, please fill in the order form on page 24 and contact the Sauer-Danfoss Sales Organization.

LS Steering Units OSPB, OSPC, OSPF, OSPD, OSPQ, OSPL

Code Numbers and Weights

OSPL load sensing static non-reaction steering units

OSPL LS Static steering units have no valve functions.

OSPL LS in the three tables below have all strong neutral setting springs, see page 24

Steering unit	Code numbers			Weight kg [lb]
	Connections			
	European version for OLS G 1/2 G 1/4 - S**	US version for OLS 3/4-16 UNF - O* 7/16-20 UNF - O* + S**	US version for OLS and OVPL LS - port 7/16-20 UNF - O* + S**	
OSPL 520 LS	150-7169	150-7167	150-7168	8.1 [17.86]
OSPL 630 LS	150-7107	150-7164	150-7113	8.4 [18.52]
OSPL 800 LS	150-7108	150-7165	150-7114	8.8 [19.40]
OSPL 1000 LS	150-7110	150-7166	150-7115	10.0 [22.05]

O*: O-ring chamfer on port connections S**: Spot face around port connection

OSPL load sensing dynamic non-reaction steering units

OSPL LS Dynamic steering units in the table below have no valve functions.

Steering unit	Code numbers		Weight kg [lb]
	Connections		
	US version for OLS 3/4-16 UNF - O* 7/16-20 UNF - O* + S**		
OSPL 520 LS	150-8243		8.1 [17.86]
OSPL 630 LS	150-8212		8.4 [18.52]
OSPL 800 LS	150-8213		8.8 [19.40]
OSPL 1000 LS	150-8214		10.0 [22.05]

O*: O-ring chamfer on port connections S**: Spot face around port connection

OSPL LS Dynamic steering units in the table below incorporate all the following valve function: • pilot pressure relief valve

Steering unit	Code numbers		Valve settings Relief valve bar [psi]	Weight kg [lb]
	Connections European version for OLS and OVPL LS: G 1/4 - S**			
OSPL 520 LS	150-8244		170 [2465]	8.1 [17.86]
OSPL 1000 LS	150-8245			10.0 [22.05]

S**: Spot face around port connection

If you require other displacements or other valve setting, please fill in the order form on page 24 and contact the Sauer-Danfoss Sales Organization.

LS Steering Units OSPB, OSPC, OSPF, OSPD, OSPQ, OSPL

Code Numbers and Weights

OSPL 1200 LS Dynamic steering unit in the table below incorporate all the following valve function:

- shock valves
- suction valves

OSPL 1200 LS in the table below has strong neutral setting springs, see page 24

Priority valve	Code numbers	Valve settings	Weight kg [lb]
	Connections US version for OLS 3/16 - 16 UNF - O* CF: 11/16 - 12 UN 7/16 - 20 UNF - O* + S**	Shock valves bar [psi]	
OSPL 1200 LS	150-7175	280 [4061]	11 [24.25]

O*: O-ring chamfer on port connections

S**: Spot face around port connection

If you require other displacements or other valve setting, please fill in the order form on page 24 and contact the Sauer-Danfoss Sales Organization.

LS Steering Units OSPB, OSPC, OSPF, OSPD, OSPQ, OSPL

Code Numbers and Weights

OSPBX and OSPLX load sensing static steering units for OSQ static

OSPBX LS and OSPLX LS Static steering units in the table below have no valve functions. OSPBX LS in the table below have all standard neutral setting springs, see page 24. OSPLX LS in the table below have all strong neutral setting springs, see page 24.

Steering unit	Code numbers		Weight kg [lb]
	Connections		
	European version G 1/2 G 1/4 - S**	US version 3/4-16 UNF - O* 7/16-20 UNF - O* + S**	
OSPBX 160 LS	150-1082	150-1078	5.6 [12.35]
OSPBX 200 LS	150-1083	150-1079	5.8 [12.79]
OSPBX 315 LS	150-1084	150-1080	6.2 [13.67]
OSPBX 400 LS	150-1085	150-1081	7.0 [15.43]
OSPLX 520 LS	150-7170	150-7173	8.1 [17.86]
OSPLX 630 LS	150-7171	150-7174	8.4 [18.52]
OSPLX 800 LS	150-7172	150-7155	8.8 [19.40]

O*: O-ring chamfer on port connections

S**: Spot face around port connection

OSPCX load sensing dynamic steering units for OSQ dynamic

OSPCX LS Dynamic steering unit in the table below incorporates the following valve function:

- pilot pressure relief valve

OSPCX LS in the table below has standard neutral setting springs, see page 24

Steering unit	Code numbers	Valve settings	Weight kg [lb]
	Connections		
	European version for OLS and OVPL G 1/2 - S** G 1/4 - S**	Relief valve bar [psi]	
OSPCX 160 LS	150-8188	200 [2900]	5.6 [12.35]

S**: Spot face around port connection

If you require other displacements or other valve setting, please fill in the order form on page 24 and contact the Sauer-Danfoss Sales Organization.

LS Steering Units OSPB, OSPC, OSPF, OSPD, OSPQ, OSPL

Specification Table for Non Catalogue Numbers of LS Steering Units

Fill in your company data and place x's in the table where appropriate, then send to your Sauer-Danfoss Sales Organisation.

Your company	Name		Vehicle			Potential pcs/year				Completed by		Date								
Steering unit type	OSPC		OSPF		OSPD		OSPQ		OSPL		OSPLX		OSPCX							
Reaction type	LS (Non-reaction)						LSR (Reaction: only OSPC, OSPF, OSPD, OSPQ)													
Load Sensing type	Static (Only OSPC, OSPL, OSPLX, OSPCX)						Dynamic													
DP, cm ³ /rev OSPC LS OSPF LS	40	50	60	70	80	100	125	160	185	200	230	250	315	400						
DP, cm ³ /rev OSPC LSR	40		50		60		70		80		100		125		160		185		200	
DP, cm ³ /rev OSPD LS	60/185	60/220	60/260	70/195	70/230	70/270	70/385	100/200	100/260	100/300	125/285	125/325	125/440							
DP, cm ³ /rev OSPD LSR	60/185			60/220			70/195			70/230			100/200							
DP, cm ³ /rev OSPQ LS	80/125	80/140	80/160	100/160	100/180	100/200	125/200	125/250	160/250	160/320										
DP, cm ³ /rev OSPQ LSR	80/125		80/140		80/160		100/160		100/180		100/200		125/200							
DP, cm ³ /rev OSPL, OSPLX	520			630			800			1000			1200 (only OSPL)							
DP, cm ³ /rev OSPCX	160			200			250			315			400							
Port threads OSPC, OSPF	G1/2			G1/2- S**			M18 x 1.5 - O* + S**			3/4-16 UNF - O*			for OLSA (only OSPC)							
Port threads OSPD	G1/2- S**						M18 x 1.5 - O* + S**						3/4-16 UNF - O*							
Port threads OSPL, OSPLX	G1/2		3/4-16 UNF - O*				For OPVL and without RV (LS = 7/16 - 20 UNF)				For OVPL and with RV (LS = G 1/4)									
Relief valve*** bar	70	80	90	100	110	120	140	170	190	200	210	no relief valve								
Shock valves bar	160		180		200		225		240		280		no shock valves							
Suction valves	Yes						No													
Check valve in LS	Yes (Only for OSPC dynamic, OSPD and OSPQ)						No (Only for OSPC, OSPF and OSPL)													
Neutral setting springs	Soft: 0.5 - 1.8 Nm in normal steering situations				Standard: 0.8 - 3 Nm in normal steering situations				Strong: 1.5 - 4 Nm in normal steering situations											
Unit black painted	Yes						No													

LS Steering Units OSPB, OSPC, OSPF, OSPD, OSPQ, OSPL

Specification Table for Non Catalogue Numbers of LS Steering Units (continued)

DP = Displacement, RV = Pilot pressure relief valve.

O*: O-ring chamfer on port connections.

S** : Spot face around port connections (can not be used in connection with OVR angular block).

RV*** see "Technical data" page 29-30 for limitation in maximum pressure depending on displacements.

Port and valve combinations possible: see tables page 26 - 28.

Types not mentioned with port connections in the table above, are only available in the version(s) stated in the code number tables.

An alternative way to specify a variant is to state an existing code number and add the modifications, you would like to have implemented in the basic steering unit.

Code number of basic steering unit: _____

Requested modifications: _____

LS Steering Units OSPB, OSPC, OSPF, OSPD, OSPQ, OSPL

Port Thread Versions and Valve Combinations

The following combinations of port threads and valves are available for OSPC LS/LSR:
Housings for low flow: 40 - 200 cm³/rev [2.44 - 12.20 in³/rev] gear wheel set.

Threads			Valves			
Main ports (P, T, L, R)	LS-port	For steering column	Pilot pressure relief valve	Shock valves	Suction valves	Check valve in LS (only for LS Dynamic)
DIN 3852-2 G 1/2	DIN 3852-2 G 1/4 w. spot face	M10 x 1.5	Yes	Yes	Yes	Yes
			Yes	Yes	Yes	No
DIN 3852-2 G 1/2 w. spot face	DIN 3852-2 G 1/4 w. spot face	M10 x 1.5	Yes	Yes	Yes	Yes
			Yes	Yes	Yes	No
ISO 6149-1 M18 x 1.5, w. O-ring chamfer and spot face	ISO 6149-1 M12 x 1.5, w. O-ring chamfer and spot face	M10 x 1.5	Yes	Yes	Yes	Yes
			Yes	Yes	Yes	No
ISO 11926-1 3/4 - 16 UNF, O-ring boss port	ISO 11926-1 7/16 - 20 UNF O-ring boss port and spot face	3/8 - 16 UNC	Yes	Yes	Yes	Yes
			Yes	No	No	No
ISO 11926-1 3/4 - 16 UNF, O-ring boss port	ISO 11926-1 7/16 - 20 UNF O-ring boss port and spot face	M10 x 1.5	Yes	Yes	Yes	Yes
			Yes	Yes	Yes	Yes
For OLSA	For OLSA	M10 x 1.5	Yes	Yes	Yes	Yes
			Yes	Yes	Yes	No
			Yes	No	No	No

The following combinations of port threads and valves are available for OSPC LS/LSR:
Housings for high flow: 250 - 400 cm³/rev [15.25 - 24.4 in³/rev] gear wheel set.

Threads			Valves			
Main ports (P, T, L, R)	LS-port	For steering column	Pilot pressure relief valve	Shock valves	Suction valves	Check valve in LS (only for LS Dynamic)
DIN 3852-2 G1/2	DIN 3852-2 G 1/4 w. spot face	M10 x 1.5	Yes	Yes	Yes	No
			No	Yes	Yes	No
DIN 3852-2 G 1/2 w. spot face	DIN 3852-2 G 1/4 w. spot face	M10 x 1.5	Yes	Yes	Yes	No
			Yes	No	No	Yes
ISO 11926-1 3/4 - 16 UNF, O-ring boss port	ISO 11926-1 7/16 - 20 UNF O-ring boss port and spot face	3/8 - 16 UNC	Yes	Yes	Yes	No
			Yes	No	No	No
			No	Yes	Yes	No
			No	Yes	No	No
ISO 11926-1 3/4 - 16 UNF, O-ring boss port	ISO 11926-1 7/16 - 20 UNF O-ring boss port and spot face	M10 x 1.5	Yes	Yes	Yes	No
			Yes	No	No	No
For OLSA	For OLSA	M10 x 1.5	Yes	Yes	Yes	No

Housings with spot face around port connections on main ports cannot be used in connection with OVR angular block.



LS Steering Units OSPB, OSPC, OSPF, OSPD, OSPQ, OSPL

Port Thread Versions and Valve Combination (continued)

The following combinations of port threads and valves are available for OSPQ LS/LSR:

Threads			Valves			
Main ports (P, T, L, R)	LS-port	For steering column	Pilot pressure relief valve	Shock valves	Suction valves	Check valve in LS (only for LS Dynamic)
ISO 6149-1 M18 x 1.5, w. O-ring chamfer and spot face	ISO 6149-1 M12 x 1.5, w. O-ring chamfer and spot face	M10 x 1.5	Yes	Yes	Yes	Yes
			No	Yes	Yes	Yes

Housings with spot face around port connections on main ports cannot be used in connection with OVR angular block.

For OSPL, OSPBX, OSPCX and OSPLX only the versions listed in the tables with code numbers are available.

LS Steering Units OSPB, OSPC, OSPF, OSPD, OSPQ, OSPL

Technical Data

Displacement, flow and pressure: OSPB LS, OSPC LS, OSPC LSR

Common data: Look in sub catalogue: "General Steering Components "

Steering unit	Displacement cm ³ /rev [in ³ /rev]	*Rated oil flow l/min [US gal/min]	Max. pressure on connections		
			P bar [psi]	T bar [psi]	L. R bar [psi]
OSPC 40 LS Static	40 [2.44]	4 [1.06]	140 [2030]	40 [580]	280 [4061]
OSPB/OSPC 50 LS Static	50 [3.05]	5 [1.32]			
OSPC 60 LS Static	60 [3.66]	6 [1.58]			
OSPC 70 LS Static	70 [4.27]	7 [1.85]	175 [2538]		
OSPB/OSPC 80 LS Static	80 [4.88]	8 [2.11]			
OSPB/OSPC 100 LS Static	100 [6.10]	10 [2.64]			
OSPB/OSPC 125 LS Static	125 [7.63]	13 [3.43]	175 [2538]		
OSPB/OSPC 160 LS Static	160 [9.76]	16 [4.23]			
OSPC 185 LS Static	185 [11.29]	19 [5.02]			
OSPB/OSPC 200 LS Static	200 [12.20]	20 [5.28]	175 [2538]		
OSPC 230 LS Static	230 [14.03]	23 [6.07]			
OSPC 250 LS Static	250 [15.25]	25 [6.60]			
OSPB/OSPC 315 LS Static	315 [19.22]	32 [8.45]	175 [2538]		
OSPB/OSPC 400 LS Static	400 [24.41]	40 [10.57]			
OSPC 40 LS Dynamic	40 [2.44]	4 [1.06]		140 [2030]	40 [580]
OSPB/OSPC 50 LS Dynamic	50 [3.05]	5 [1.32]			
OSPC 60 LS Dynamic	60 [3.66]	6 [1.58]			
OSPC 70 LS Dynamic	70 [4.27]	7 [1.85]	175 [2538]		
OSPB/OSPC 80 LS Dynamic	80 [4.88]	8 [2.11]			
OSPB/OSPC 100 LS Dynamic	100 [6.10]	10 [2.64]			
OSPB/OSPC 125 LS Dynamic	125 [7.63]	13 [3.43]	210 [3045]		
OSPB/OSPC 160 LS Dynamic	160 [9.76]	16 [4.23]			
OSPC 185 LS Dynamic	185 [11.29]	19 [5.02]			
OSPB/OSPC 200 LS Dynamic	200 [12.20]	20 [5.28]	210 [3045]		
OSPC 230 LS Dynamic	230 [14.03]	23 [6.07]			
OSPC 250 LS Dynamic	250 [15.25]	25 [6.60]			
OSPB/OSPC 315 LS Dynamic	315 [19.22]	32 [8.45]	210 [3045]		
OSPB/OSPC 400 LS Dynamic	400 [24.41]	40 [10.57]			
OSPC 40 LSR Dynamic	40 [2.44]	4 [1.06]		140 [2030]	40 [580]
OSPC 50 LSR Dynamic	50 [3.05]	5 [1.32]			
OSPC 60 LSR Dynamic	60 [3.66]	6 [1.58]			
OSPC 70 LSR Dynamic	70 [4.27]	7 [1.85]	175 [2538]		
OSPC 80 LSR Dynamic	80 [4.88]	8 [2.11]			
OSPC 100 LSR Dynamic	100 [6.10]	10 [2.64]			
OSPC 125 LSR Dynamic	125 [7.63]	13 [3.43]	210 [3045]		
OSPC 160 LSR Dynamic	160 [9.76]	16 [4.23]			
OSPC 185 LSR Dynamic	185 [11.29]	19 [5.02]			
OSPC 200 LSR Dynamic	200 [12.20]	20 [5.28]	210 [3045]		

*Rated flow at 100 rpm

LS Steering Units OSPB, OSPC, OSPF, OSPD, OSPQ, OSPL

Technical Data

Displacement, flow and pressure: OSPF LS

Common data: Look in sub catalogue: "General Steering Components"

Steering unit	Displacement cm ³ /rev [in ³ /rev]	*Rated oil flow l/min [US gal/min]	Max. pressure on connections		
			P bar [psi]	T bar [psi]	L R bar [psi]
OSPF 50 LS Dynamic	50 [3.05]	5 [1.32]	140 [2030]	40 [580]	280 [4061]
OSPF 60 LS Dynamic	60 [3.66]	6 [1.58]			
OSPF 70 LS Dynamic	70 [4.27]	7 [1.85]			
OSPF 80 LS Dynamic	80 [4.88]	8 [2.11]	175 [2538]		
OSPF 100 LS Dynamic	100 [6.10]	10 [2.64]			
OSPF 125 LS Dynamic	125 [7.63]	13 [3.43]			
OSPF 160 LS Dynamic	160 [9.76]	16 [4.23]	210 [3045]		
OSPF 185 LS Dynamic	185 [11.29]	19 [5.02]			
OSPF 200 LS Dynamic	200 [12.20]	20 [5.28]			
OSPF 230 LS Dynamic	230 [14.03]	23 [6.07]			
OSPF 250 LS Dynamic	250 [15.25]	25 [6.60]			
OSPF 315 LS Dynamic	315 [19.22]	32 [8.45]			
OSPF 400 LS Dynamic	400 [24.41]	40 [10.57]			

*Rated flow at 100 rpm

LS Steering Units OSPB, OSPC, OSPF, OSPD, OSPQ, OSPL

Technical Data

Displacement, flow and pressure: OSPL LS, OSPBX LS, OSPCX LS, OSPLX LS

Common data: Look in sub catalogue: "General Steering Components "

Steering unit	Displacement cm ³ /rev [in ³ /rev]	*Rated oil flow l/min [US gal/min]	Max. pressure on connections		
			P bar [psi]	T bar [psi]	L R bar [psi]
OSPL 520 LS Static	520 [31.73]	52 [13.74]	210 [3045]	40 [580]	280 [4061]
OSPL 630 LS Static	630 [38.44]	63 [16.64]			
OSPL 800 LS Static	800 [48.82]	70** [18.49]			
OSPL 1000 LS Static	1000 [61.02]	70** [18.49]			
OSPL 520 LS Dynamic	520 [31.73]	52 [13.74]	240 [3081]	40 [580]	280 [4061]
OSPL 630 LS Dynamic	630 [38.44]	63 [16.64]			
OSPL 800 LS Dynamic	800 [48.82]	70** [18.49]			
OSPL 1000 LS Dynamic	1000 [61.02]	70** [18.49]			
OSPL 1200 Dynamic	1200 [73.22]	70** [18.49]			
OSPBX 160 LS Static	160 [9.76]	16 [4.23]	210 [3045]	40 [580]	280 [4061]
OSPBX 200 LS Static	200 [12.20]	20 [5.28]			
OSPBX 250 LS Static	250 [15.25]	25 [6.60]			
OSPBX 315 LS Static	315 [19.22]	32 [8.45]			
OSPBX 400 LS Static	400 [24.41]	40 [10.57]			
OSPCX 160 LS Dynamic	160 [9.76]	16 [4.23]	210 [3045]	40 [580]	280 [4061]
OSPCX 200 LS Dynamic	200 [12.20]	20 [5.28]			
OSPCX 250 LS Dynamic	250 [15.25]	25 [6.60]			
OSPCX 315 LS Dynamic	315 [19.22]	32 [8.45]			
OSPCX 400 LS Dynamic	400 [24.41]	40 [10.57]			
OSPLX 520 LS Static	520 [31.73]	52 [13.74]	210 [3045]	40 [580]	280 [4061]
OSPLX 630 LS Static	630 [38.44]	63 [16.64]			
OSPLX 800 LS Static	630 [38.44]	70** [18.49]			

* Rated flow at 100 rpm

** Please contact Sauer-Danfoss Sales Organization for flow higher than 70l/min [18.49 US gal/min].
70l/min [18.49 US gal/min] results in lower max. speed than 100 rpm on steering wheel for OSPL 800 and OSPL 1000:
OSPL 800 max. speed at 70l/min [18.49 US gal/min] 87 rpm
OSPL 1000 max speed at 70l/min [18.49 US gal/min] 70 rpm

LS Steering Units OSPB, OSPC, OSPF, OSPD, OSPQ, OSPL

Technical Data

Valve functions in OSPC, OSPF, OSPD, OSPQ and OSPL LS steering units

Pilot pressure relief valve; (P - T, Qp) characteristic

The pilot pressure relief valve protects the steering unit against excessive pressure. The pilot pressure relief valve in the OSPC LS, OSPF LS, OSPD LS, OSPQ LS and OSPL LS steering unit together with the priority valve limit the maximum steering pressure P-T. The pilot pressure relief valve is set at an oil flow to the priority valve of 25 l/min [6.60 US gal/min].

For OSPC, OSPD, OSPQ and OSPL load sensing dynamic steering units, the setting values are valid at a dynamic flow of 0.6 l/min [0.16 US gal/min].

For OSPF load sensing dynamic steering units, the setting values are valid at a dynamic flow of 1.1 l/min [0.29 US gal/min].

Setting tolerance:

<= 170 bar: rated value +5 bar [72.5 psi].

> 170 bar: rated value +10 bar [145 psi].

$$A = 170 \begin{matrix} +5 \\ -0 \end{matrix} \text{ bar } [2465 + \begin{matrix} 73 \\ -0 \end{matrix} \text{ psi}]$$

$$B = 140 \begin{matrix} +5 \\ -0 \end{matrix} \text{ bar } [2030 + \begin{matrix} 73 \\ -0 \end{matrix} \text{ psi}]$$

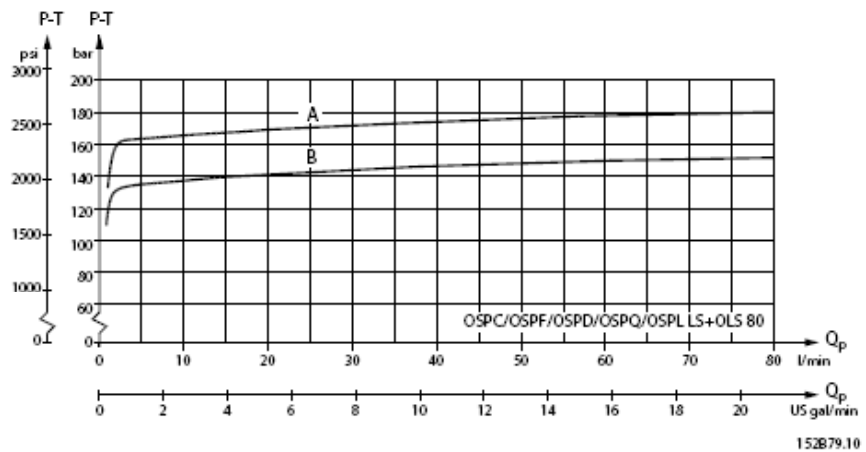

Shock valves

The shock valves protect the steering unit and reduce external forces on the steering cylinder by limiting the pressure difference from L to T and from R to T.

The shock valves are set at 3 l/min [0.792 US gal/min]

At higher flow pressure peaks may occur.

The shock valves are of the direct acting type, so they react very quickly.

Setting tolerance: rated value +20 bar [290 psi].

LS Steering Units OSPB, OSPC, OSPF, OSPD, OSPQ, OSPL

Technical Data

Suction Valves

The suction valves allow oil suction to avoid cavitation in the steering cylinder. To provide correct suction, a back pressure valve must be fitted in the tank line from the steering unit.

Generally Sauer-Danfoss recommend a back pressure of 2 bar [29 psi], but on vehicles with strong self straightening tendencies and on articulated steered vehicles, we recommend 5-10 bar [72.5 - 145 psi]. For further advice, please contact the Sauer-Danfoss Sales Organisation.

Note: A connection which incorporates a check valve must be established to allow oil flow to by-pass the back pressure valve (and filter) from the tank to steering unit. See diagramme examples in sub catalogue "General Steering Components" page 37 - 39.

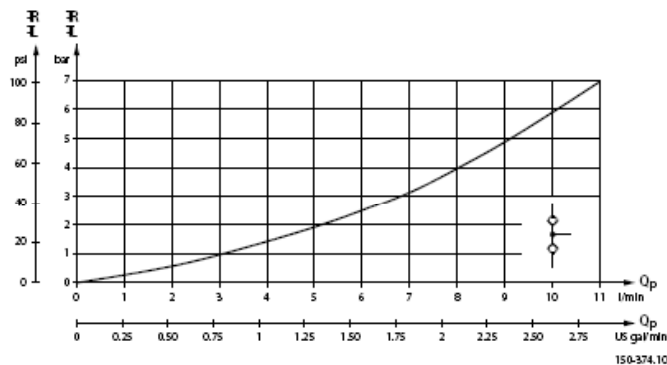

Check valves

The check valve in the P connection of the steering unit protects the driver against steering wheel jerks. The check valve prevents oil from flowing backwards into the pump line when steering against a high pressure on the cylinder side. The pressure drop across the check valve is indicated on the following graph, which assumes the use of port adaptors with 11 mm [0.43 in] minimum bore.

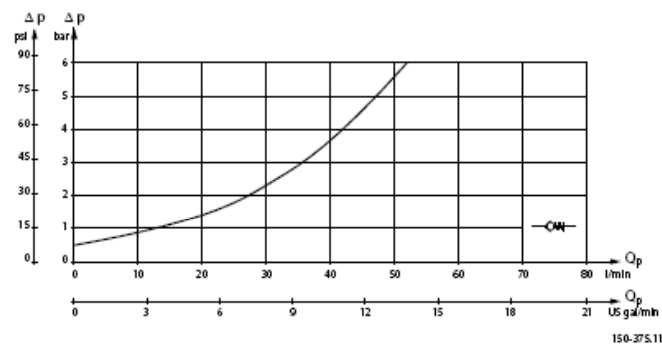

The check valve in the LS line of OSPC LS, OSPD LS and OSPQ LS dynamic steering units also protects the driver against steering wheel jerks. The check valve prevents oil from flowing backwards into the LS line to the priority valve when steering against a high pressure on the cylinder side.

In OSPF LS oil cannot flow backwards into the LS line, look in sub catalogue: "General Steering Components" page 26.



LS Steering Units OSPB, OSPC, OSPF, OSPD, OSPQ, OSPL

Port Thread Versions for

OSPB LS,
OSPC LS/LSR,
OSPF LS,
OSPD LS/LSR,
OSPQ LS/LSR,
OSPL LS,
OSPBX LS,
OSPCX LS,
OSPLX LS

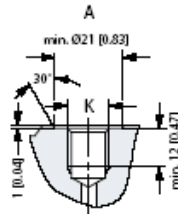

A: G port w. spot face
(LS in OSPB and OSPL
with no valves)
K: DIN 3852-2 - G ¼

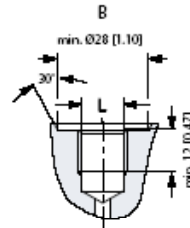

B: G port w. spot face
(LS in OSPC/F/D/Q
and OSPL with valves)
L: DIN 3852-2 - G ¼

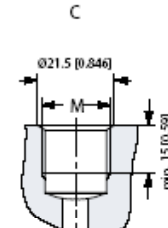

C: G ports (P, T, L, R)
M: DIN 3852-2 - G ¼

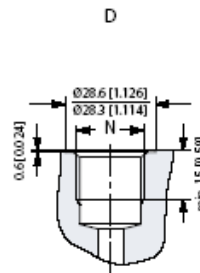

D: G ports w. spot face
(P, T, L, R)
N: DIN 3852-2 - G ¼

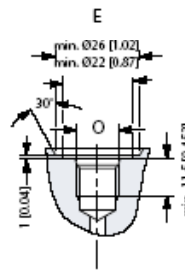

E: Metric port w. spot
face and O-ring
chamfer (LS)
O: ISO 6149-1 - M12 x 1.5

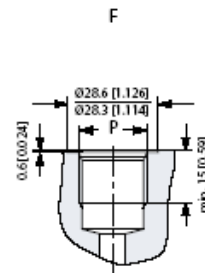

F: Metric ports
w. spot face and
O-ring chamfer
(P, T, L, R)
P: ISO 6149-1 - M18 x 1.5

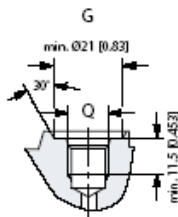

G: UNF port w. O-ring chamfer
(LS in OSPB
and OSPL with
no valves)
Q: ISO 11926-1 - 7/16-20UNF
O-ring boss port

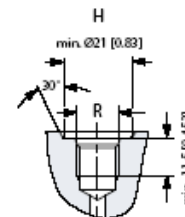

H: UNF ports w. O-ring
chamfer (LS in OSPC/
F/D and OSPL
with valves)
R: ISO 11926-1 - 7/16-20 UNF
O-ring boss port

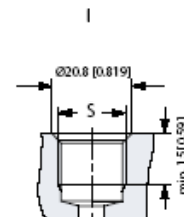

I: UNF ports w. O-ring^{150-609.10}
chamfer (P, T, L, R)
S: ISO 11926-1 - ¾-16UNF
O-ring boss port

LS Steering Units OSPB, OSPC, OSPF, OSPD, OSPQ, OSPL

Dimensions

OSPB LS for OLS, OSPBX LS for OSQ

Type	L ₁ mm [in]	L ₂ mm [in]
OSPB 50	126 [4.96]	6.5 [0.26]
OSPB 80	129 [5.08]	10.4 [0.41]
OSPB 100	132 [5.20]	13.0 [0.51]
OSPB 125	135 [5.31]	16.2 [0.64]
OSPB/ OSPBX 160	140 [5.51]	20.8 [0.82]
OSPB/ OSPBX 200	145 [5.71]	26.0 [1.02]
OSPB/ OSPBX 250	151 [5.94]	32.5 [1.28]
OSPB/ OSPBX 315	160 [6.30]	40.9 [1.61]
OSPB/ OSPBX 400	171 [6.73]	52.0 [2.05]

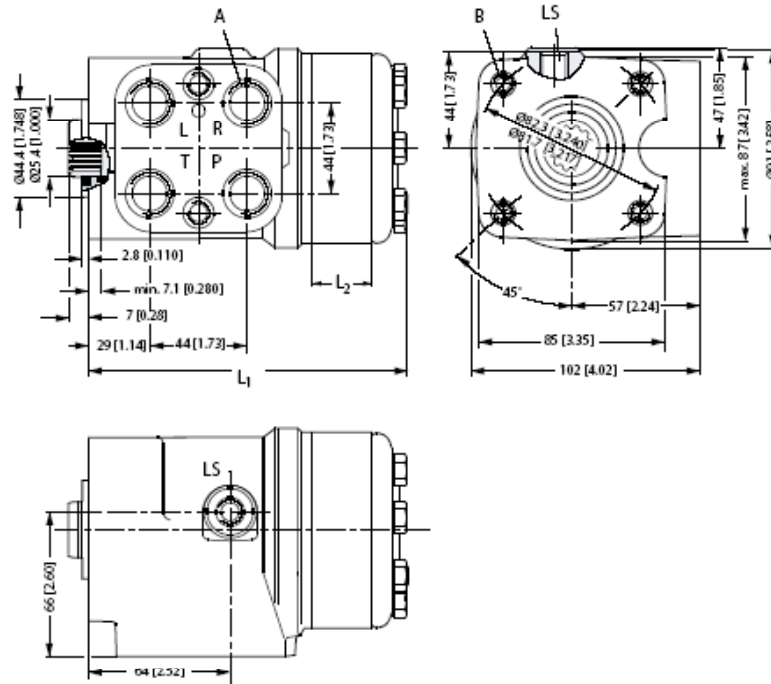

European version:

- A: G ½; 15 mm [0.59 in] deep
- B: M10 × 1.5,
16 mm [0.63 in] deep
- LS: G ¼ with spot face, 11 mm
[0.43 in] deep

US version:

- A: ¾ - 16 UNF O-ring boss,
15 mm [0.59 in] deep
- B: 3/8 - 16 UNC,
16 mm [0.63 in] deep
- LS: G 7/16 - 20 UNF O-ring boss,
11.5 mm [0.45 in] deep



150-590.11

LS Steering Units OSPB, OSPC, OSPF, OSPD, OSPQ, OSPL

Dimensions

OSPD LS/LSR for OLS

Type	mm L ₁ [in]	mm L ₂ [in]	mm L ₃ [in]
OSPD 60/185	195 [7.70]	9.1 [0.36]	20.8 [0.82]
OSPD 60/220	200 [7.87]	9.1 [0.36]	26.0 [1.02]
OSPD 70/195	190 [7.48]	9.1 [0.36]	16.2 [0.65]
OSPD 70/230	195 [7.70]	9.1 [0.36]	20.8 [0.82]
OSPD 70/270	200 [7.87]	9.1 [0.36]	26.0 [1.02]
OSPD 70/385	215 [8.46]	9.1 [0.36]	40.9 [1.61]
OSPD 100/200	191 [7.52]	13.0 [0.51]	13.0 [0.51]
OSPD 100/260	199 [7.83]	13.0 [0.51]	20.8 [0.82]
OSPD 100/300	204 [8.03]	13.0 [0.51]	26.0 [1.02]
OSPD 125/285	202 [7.95]	16.2 [0.64]	20.8 [0.82]
OSPD 125/325	207 [8.15]	16.2 [0.64]	26.0 [1.02]
OSPD 125/440	222 [8.74]	16.2 [0.64]	40.9 [1.61]

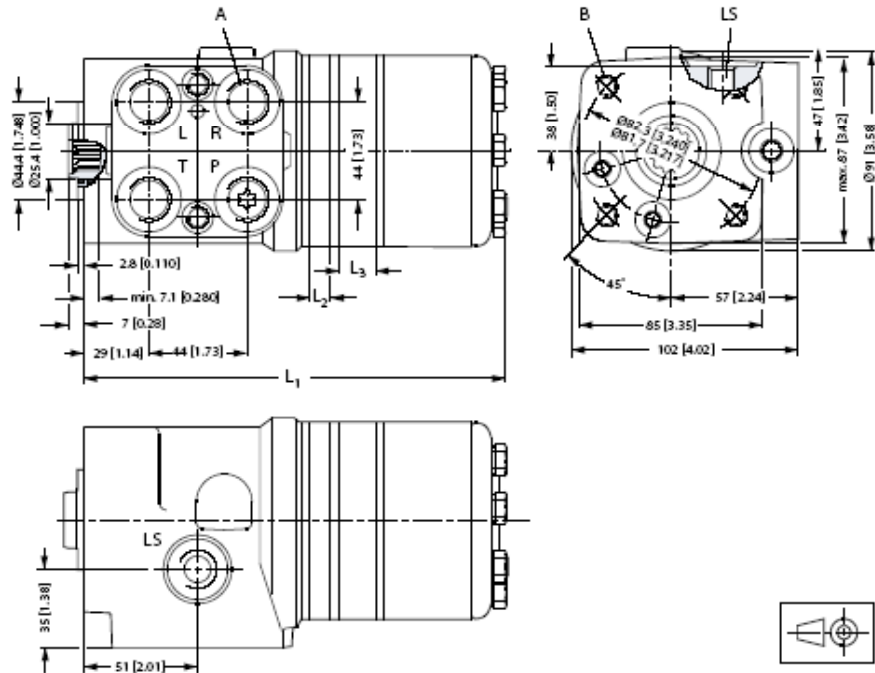

150-S93.11

European version:

- A: G ½ w. spot-face
or M18 × 1.5 ISO 6149
15 mm [0.59 in] deep
- B: M10 × 1.5, 16 mm [0.63 in]
deep
- LS: G ¼ w. spot face or
M 12 x 1.5 ISO 6149
11.5 mm [0.45 in] deep

US version:

- A: ¾ - 16 UNF O-ring boss;
15 mm [0.59 in] deep
- B: M 10 × 1.5, 16 mm [0.63 in]
deep,
- LS: 7/16 - 20 UNF o-ring boss,
11.5 mm [0.45 in] deep

LS Steering Units OSPB, OSPC, OSPF, OSPD, OSPQ, OSPL

Dimensions

OSPQ LS/LSR for OLS

Type	L ₁ mm L ₁ [in]	L ₂ mm L ₂ [in]
OSPQ 80/125	129 [5.08]	10.4 [0.41]
OSPQ 80/140	129 [5.08]	10.4 [0.41]
OSPQ 80/160	129 [5.08]	10.4 [0.41]
OSPQ 100/160	132 [5.20]	13.0 [0.51]
OSPQ 100/180	132 [5.20]	13.0 [0.51]
OSPQ 100/200	132 [5.20]	13.0 [0.51]
OSPQ 125/200	135 [5.31]	16.2 [0.64]
OSPQ 125/250	135 [5.31]	16.2 [0.64]
OSPQ 160/250	140 [5.51]	20.8 [0.82]
OSPQ 160/320	140 [5.51]	20.8 [0.82]

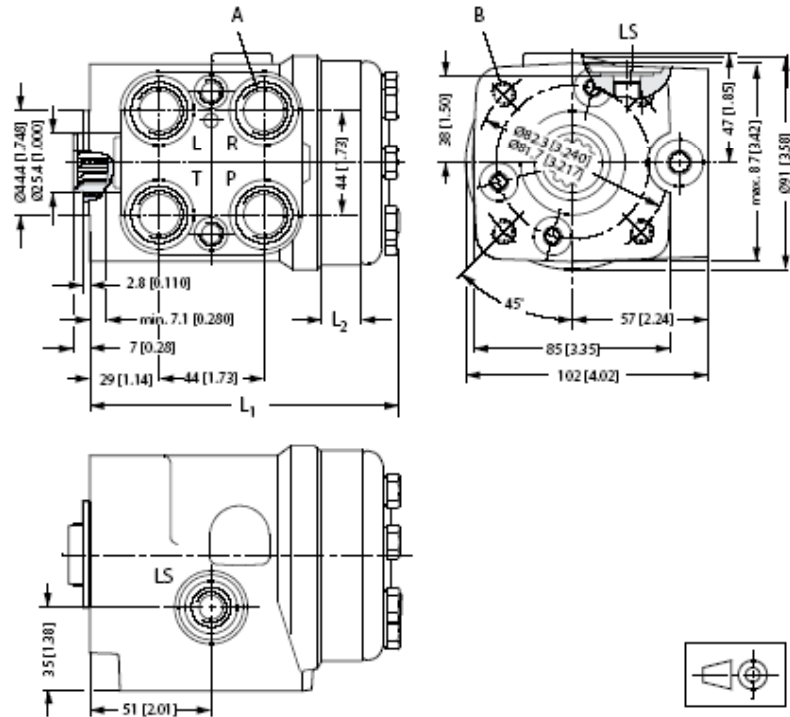

150-594.12

European version:

- A: M18 x 1.5 ISO 6149,
15 mm [0.59 in] deep
- B: M10 x 1.5, 16 mm [0.63 in]
deep
- LS: M12 x 1.5 ISO 6149,
11.5 mm [0.45 in] deep

LS Steering Units OSPB, OSPC, OSPF, OSPD, OSPQ, OSPL

Dimensions

OSPL LS for OLS and OSPLX LS for OSQ

Type	mm L ₁ [in]	mm L ₂ [in]
OSPL/OSPLX 520	197 [7.76]	67.8 [2.67]
OSPL/OSPLX 630	211 [8.31]	82.0 [3.23]
OSPL/OSPLX 800	233 [9.17]	104.0 [4.09]
OSPL 1000	263 [10.35]	134.0 [5.27]

European version:
 A: G 1/2; 15 mm [0.59 in] deep
 B: M10 x 1.5, 16 mm [0.63 in] deep
 LS: G 1/4 w. spot face, 11.5 mm [0.45 in] deep

US version:
 A: 3/4-16 UNF O-ring boss, 15 mm [0.59 in] deep or for OVPL
 B: M10 x 1.5, 16 mm [0.63 in] deep
 LS: 7/16-20 UNF O-ring boss, 11.5 mm [0.45 in] deep

OSPL LS with pilot pressure relief valve:

European version:
 A: for OVPL
 B: M10 x 1.5, 16 mm [0.63 in] deep
 LS: G 1/4 w. spot face, 11.5 mm [0.45 in] deep

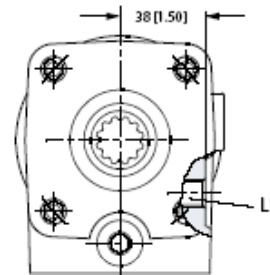
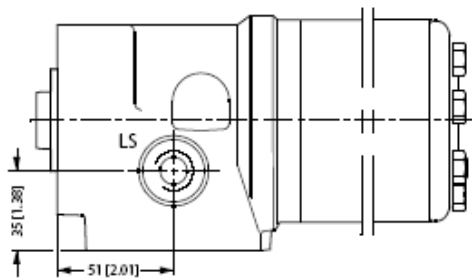
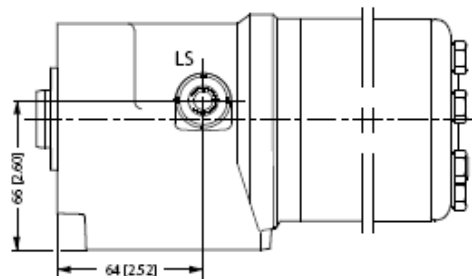
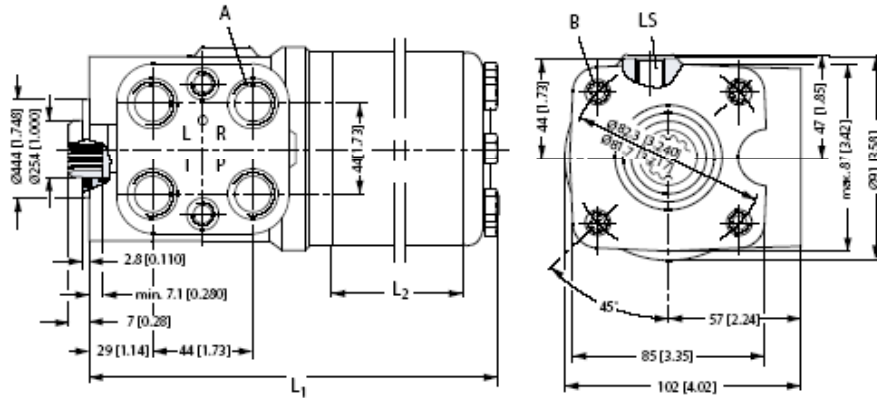

OSPL LS with relief valve

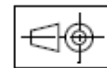

P301 030

LS Steering Units OSPB, OSPC, OSPF, OSPD, OSPQ, OSPL

Dimensions

OSPL 1200 LS for OLS

Type	mm L ₁ [in]	mm L ₂ [in]	mm L ₃ [in]
OSPL 1200 LS	288 [10.34]	104 [4.09]	52 [2.05]

- A: $\frac{3}{4}$ -16 UNF O-ring boss,
15 mm [0.59 in] deep
B: M10 x 1.5, 16 mm [0.63 in] deep
LS: $\frac{7}{16}$ -20 UNF O-ring boss
11.5 mm [0.45 in] deep

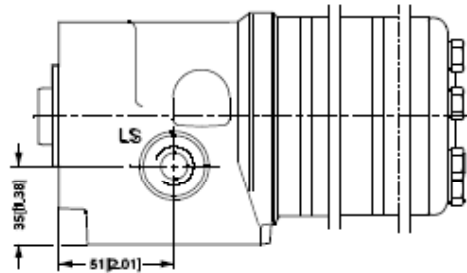
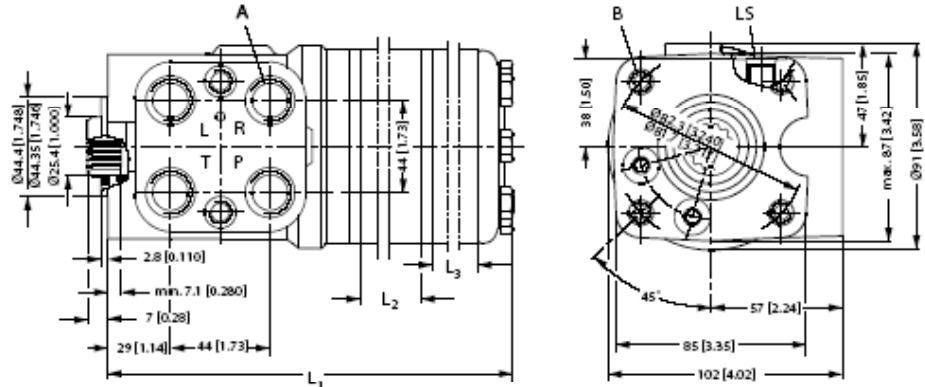

150-012.10

Valve Block OVPL

Valve Block OVPL

OVPL valve blocks can be flanged onto Sauer-Danfoss steering units type OSPL, which are prepared for OVPL mounting.

Versions

OVPL valve blocks contain shock valves, suction valves, check valve and back-pressure valve. OVPL valve blocks are available with 4, 5 or 7 connections. OVPL with 7 connections have 2 L and 2 R connections, which means that 2 steering cylinders can be connected directly to the valve block.



F300629

OVPL, 7 ports

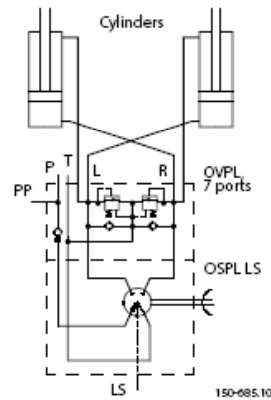

150-685.10

Code Numbers and Weights

OVPL Valve blocks

OVPL in the table below have all the following valve functions incorporated:

- Check valve in P-port
- Shock valves
- Suction valves

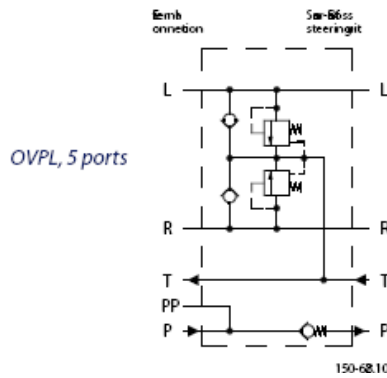

OVPL, 5 ports

150-682.10

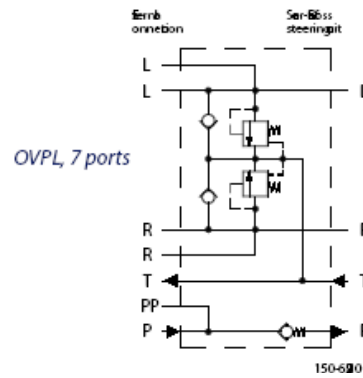

OVPL, 7 ports

150-680

Valve block	Code numbers	Number of ports	Valve settings	Weight	
	Connections European version P, T, L, R: G 1/2-5** PP: G 1/4-5**		Shock valve bar [psi]	kg	[lb]
OVPL 24	152-1117	5	240 [3480]	2.0	[4.41]
OVPL 28	152-1114	5	280 [4061]	2.0	[4.41]
OVPL 28	152-1116	7	280 [4061]	2.0	[4.41]

S** : Spot face around port connections



Valve Block OVPL

Code Numbers and Weights (continued)

OVPL in the table below has the following valve functions incorporated:

- Check valve in P-port
- Shock valves
- Suction valves
- Backpressure valve, with by-pass to reduce stand-by pressure in neutral position.

OVPL, 5 ports and backpressure valve with by-pass

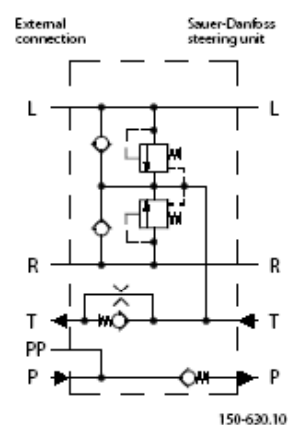

150-630.10

Valve block	Code numbers	Number of ports	Valve settings	Weight	
	Connections European version P, T, L, R: G 1/2-S** PP: G 1/4-S**		Shock valve bar [psi]	kg	[lb]
OVPL 24	152-1120	5	240 [3480]	2.0	[4.41]
OVPL 28	152-1130	5	280 [4061]	2.0	[4.41]

S** : Spot face around port connections

Valve Block OVPL

Code Numbers and Weights (continued)

OVPL in the table below have all the following valve functions incorporated:

- Check valve in P-port
- Shock valves
- Suction valves
- Backpressure valve, without by-pass.

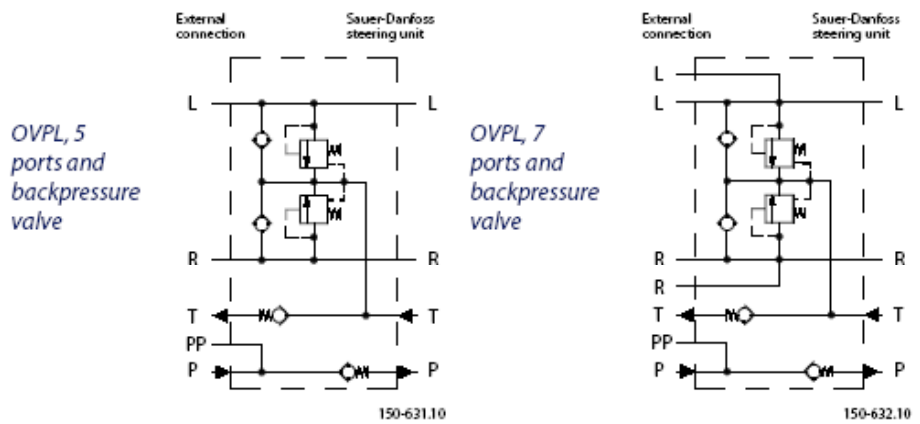

Valve block	Code numbers	Number of ports	Valve settings	Weight	
	Connections European version P, T, L, R: G 1/2- S** PP: G 1/4- S**		Shock valve bar [psi]	kg	[lb]
OVPL 24	152-1132	5	240 [3480]	2.0	[4.41]
OVPL 28	152-1115	7	280 [4061]	2.0	[4.41]

S** : Spot face around port connections

Valve Block OVPL

Code Numbers and Weights (continued)

OVPL in the table below has following valve functions incorporated:

- Check valve in P-port
- Shock valves
- Suction valves

OVPL, 4 ports

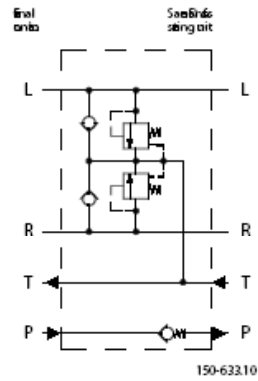

Valve block	Code numbers	Number of ports	Valve settings	Weight	
	Connections US version 3/4- 16 UNF O* + S**		Shock valve bar [psi]	kg	[lb]
OVPL 28	152-1133	4	280 [4061]	2.0	[4.41]

O* : O-ring chamfer on port connections
S** : Spot face around port connections

OVPL in the table below has the following valve functions incorporated:

- Check valve in P-port
- Shock valves
- Suction valves
- Backpressure valve with by-pass to reduce stand-by pressure in neutral position.

OVPL, 4 ports and backpressure valve with by-pass

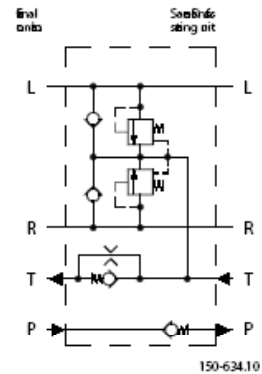

Valve block	Code numbers	Number of ports	Valve settings	Weight	
	Connections US version 3/4- 16 UNF O* + S**		Shock valve bar [psi]	kg	[lb]
OVPL 28	152-1136	4	280 [4061]	2.0	[4.41]

O* : O-ring chamfer on port connections
S** : Spot face around port connections



Valve Block OVPL

Technical Data

Common data

Look in sub-catalogue: "General, steering components"

Valve functions

The data below come from measurements on a representative sample of valve blocks from production.

An oil with a viscosity of 21 mm²/s [SUS] at 50°C [122°F] was used during measuring.

Valve block	Max. Oil flow l/min [US gal/min]		Max. pressure on connections					
			P, PP bar [psi]		T bar [psi]		L, R bar [psi]	
OVPL 24	100	[26.42]	190	[2756]	15	[218]	240	[3480]
OVPL 28	100	[26.42]	225	[3263]	15	[218]	280	[4061]

Shock valves

The shock valves protect the valve block and steering unit and limit maximum external forces on the steering cylinder. The shock valves in the valve block limit the maximum pressure drop from L to T and from R to T.

The shock valves are set at 10 l/min. [2.64 US gal/min].

The shock valves are of the direct acting type, so they react very quickly.

Setting tolerance: rated value +/- 10 bar [145 psi], ex. 240 [3480 psi] +/- 10 bar [145 psi].

Suction valves

The suction valves ensure oil suction to avoid cavitations in the steering cylinder. To provide correct suction, a back pressure valve must be fitted in the tank line from the steering unit.

The capacity of the suction valves can be increased by building in a back pressure in the valve block.

The curve below shows pressure drop across a suction valve

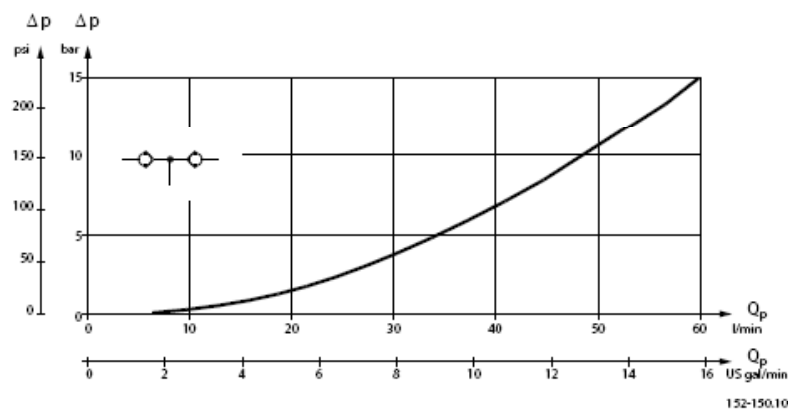

Valve Block OVPL

Technical Data (continued)

Check valve

The check valve protects the driver against steering wheel jerks. The check valve prevents oil from flowing backwards into the pump line when steering against a high pressure on the cylinder side.

The check valve is built into the P connection of the valve block.

The curve below shows pressure drop across the check valve in p-connection

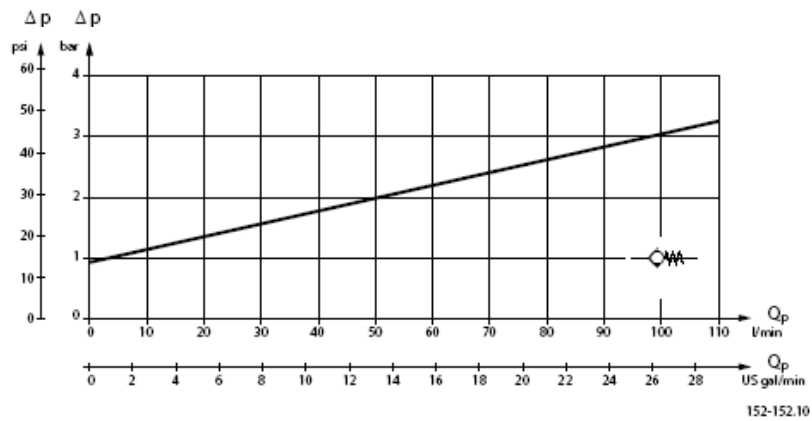

Backpressure valve

A backpressure valve increases the capacity of the suction valves.

The curve below shows pressure drop for backpressure valve without by-pass.

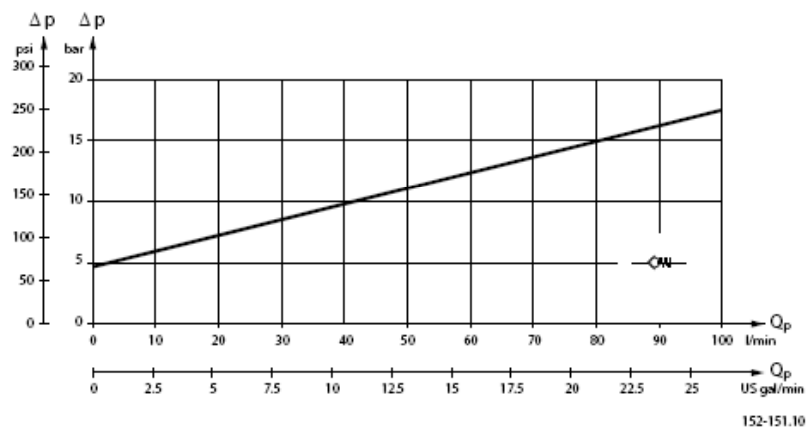

Valve Block OVPL

Technical Data (continued)

The curve below shows pressure drop for backpressure valve with by-pass.

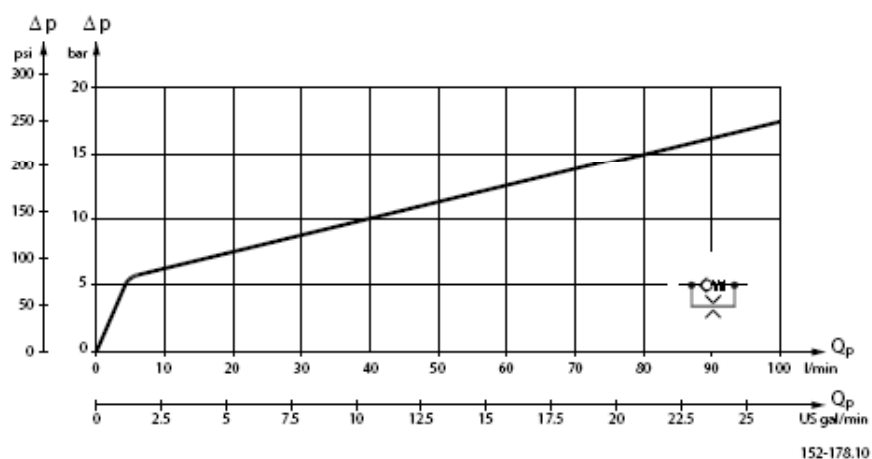

Installation

Connection P in the valve block must be placed over the connection P in the steering unit, so OVPL is provided with a positioning pin to fit the positioning hole in the steering unit.

The valve block is supplied inclusive of 2 mounting screws and 4 O-rings for building onto the steering unit.

Tightening torque $65 \pm 5 \text{ N}\cdot\text{m}$ [$575 \pm 44 \text{ lbf}\cdot\text{in}$]. It is only allowed to mount OVPL blocks on steering units with a flat port flange, no spot face is allowed.

Valve Block OVPL

Dimensions

OVPL, 5 ports

European version:

P, T, L and R:

G ½ w. spot face,

15 mm (0.59 in) deep

PP: G ¼, w. spot face,

11,5 mm (0.45 in) deep

X: 30,2 +0,2

Y: 21,3 +/- 0,2

OVPL, 4 ports (no PP)

US version:

P, T, L and R:

¾ -16 UNF O-ring boss

15 mm (0.59 in) deep

X: 30,2 +0,2

B: Positioning pin
premounted in OVPL

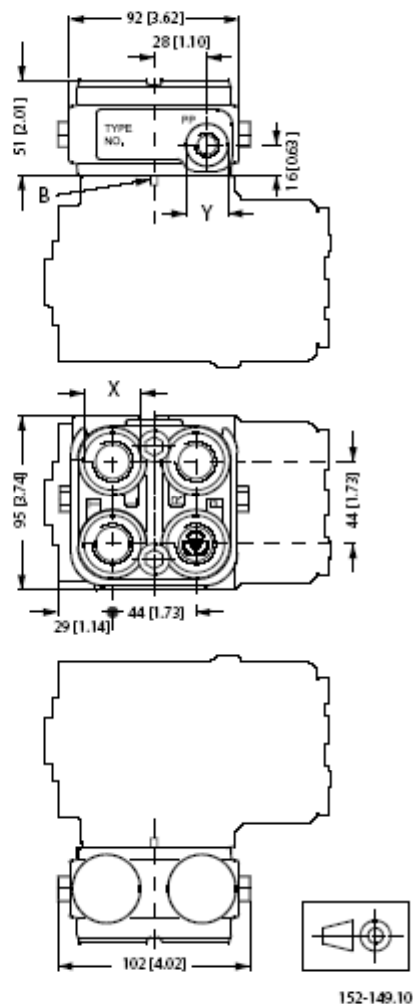

Valve Block OVPL

Dimensions (continued)

OVPL, 7 ports

European version:
 P, T, 2xL and 2xR:
 G ½ w. spot face,
 15 mm (0.59 in) deep
 PP: G ¼, w. spot face,
 11,5 mm (0.45 in) deep
 X: 30,2 +0,2
 Y: 21,3 +/- 0,2

B: Positioning pin
 premounted in OVPL

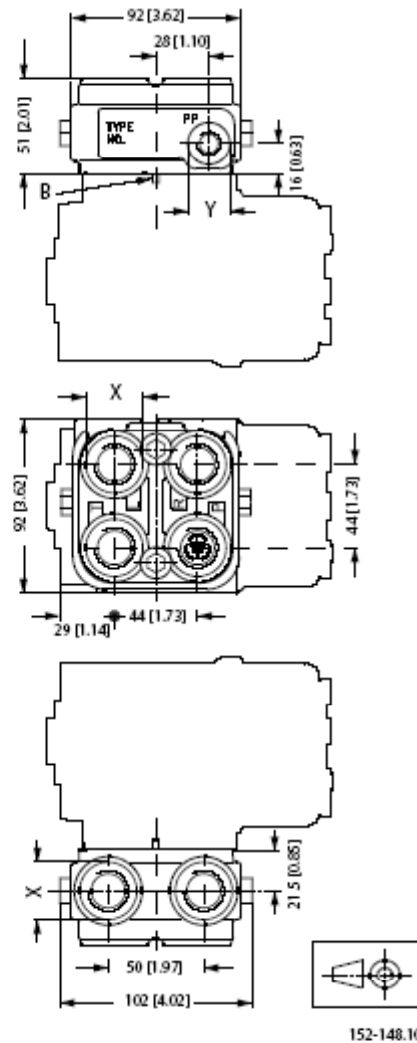

Angle Block OVR

Angle Block OVR

OVR angle blocks are especially designed for applications in which pipes and/or hoses must run parallel with the steering column axis, and where space is limited. The valve block can be flanged onto Sauer-Danfoss steering unit OSPB, OSPC, OSPD, OSPF, OSPQ and OSPL, which have no spot face around the ports. Use the angle block makes angle and swivel connections and pipe bends unnecessary. The OVR connections are positioned away from the steering wheel. (see *dimensions* page 53)

Version

OVR

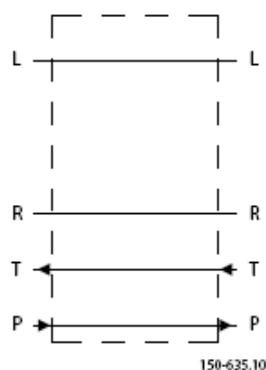

F300 626

Code Numbers and Weight

OVR in the table below has no valve functions incorporated.

Angle block	Code numbers	Weight	
	Connections European version P, T, L, R: G 1/2 S**	kg	[lb]
OVR	152-0201	2.0	[4.41]

S** : Spot face around port connections

Installation

The valve block is supplied inclusive of 2 mounting screws and 4 O-rings for building onto the steering unit.

Tightening torque $65 \pm 5 \text{ N}\cdot\text{m}$ [$575 \pm 44.3 \text{ lbf}\cdot\text{in}$]. OVR blocks may only be mounted on steering units with a flat port flange, (no spot facing).

For OVR blocks with other thread ore kind of valves mounted, please contact the Sauer-Danfoss Sales organisation.



Angle Block OVR

Dimensions

OVR

European version:
P, T, L and R:
G ½, 15 mm (0.59 in) deep

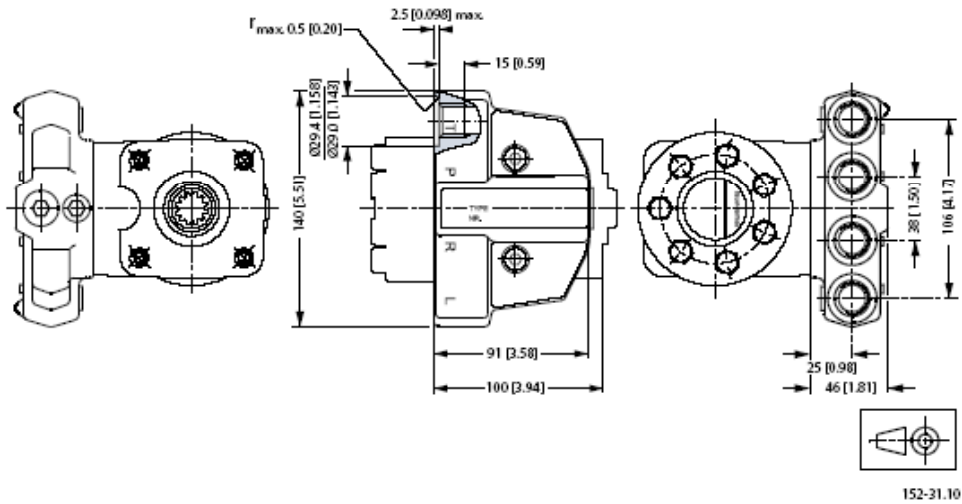

152-31.10

Priority Valves OLSA and OLS

Versions

Sauer-Danfoss priority valves are used in steering systems with load sensing steering units. In such systems steering always has first priority

Load sensing static priority valves

Load sensing static steering units require load sensing static priority valves. Load sensing static steering systems have no oil flow in the LS connection when the steering unit is in neutral position.

Load sensing dynamic priority valves

Load sensing dynamic steering units require load sensing dynamic priority valves. Load sensing dynamic steering systems have a constant oil flow in the LS connection from the priority valve to the steering unit even when the steering unit is in neutral position.

Ports:

P = pump,
 CF = controlled flow (priority oil flow),
 EF = excess flow,
 L = left,
 R = right,
 T = tank,
 LS = load sensing,
 PP = pilot pressure

OLSA 40/80

The OLSA 40 and OLSA 80 "flange on" priority valves are used in load sensing steering systems, built onto OSPC LS (OLSA) steering units.



F200625

OLSA static

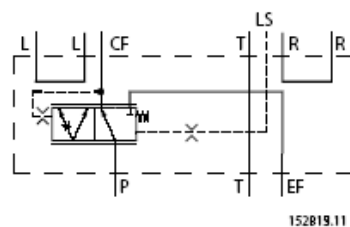

152819.11

OLSA dynamic

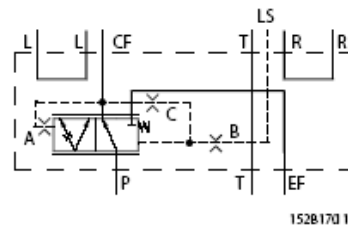

1528170.1

A: PP-damping orifice
 B: LS-orifice
 C: Dynamic-orifice



Priority Valves OLSA and OLS

Versions

The OLS 40, OLS 80 and OLS 120 "in line" priority valves are used in load sensing steering systems together with OSPB LS, OSPC LS, OSPF LS, OSPD LS, OSPQ LS and OSPL LS steering units.

OLS 40/80



F300624

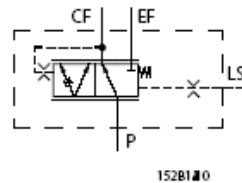

152B110

OLS static

OLS 120



F300623

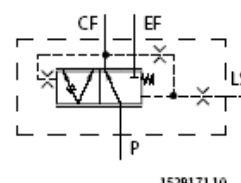

152B171.10

OLS dynamic

The OLS 160 "in line" priority valve is used in load sensing steering systems together with OSPB LS, OSPC LS, OSPF LS, OSPD LS, OSPQ LS and OSPL LS steering units.

OLS 160



F300622

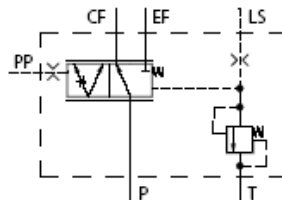

152B12.11

OLS static

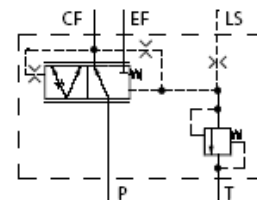

152B172.11

OLS dynamic

OLS 160 is also available without pilot pressure relief valve.



Priority Valves OLSA and OLS

Versions (continued)

The priority valve OLSP 80 is to be used in connection with e.g. Sauer-Danfoss gear pumps type SNP and steering units type OSPB LS, OSPC LS, OSPF LS, OSPD LS and OSPQ LS in load sensing steering systems, where maximum oil flow doesn't exceed 80 l/min [21.7 USgal/min].

OLSP 80 priority valves are to be flanged on gear pumps with outlet ports square flange type 35 (35 mm pitch diameter of 4x M6 bolt holes for fixing the priority valve on pump).

OLSP 80

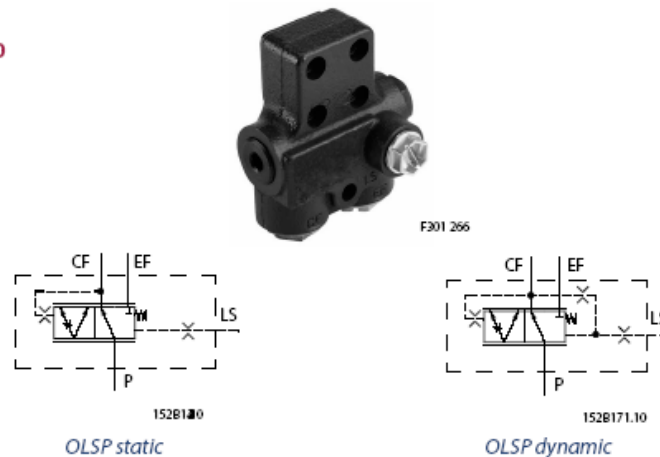

The priority valve OLS 320 is to be used in connection with large pumps and steering units type OSPB LS, OSPC LS, OSPF LS, OSPD LS, OSPQ LS and OSPL LS or with EHPS steering valve in load sensing steering systems, where maximum oil flow doesn't exceed 320 l/min [84.5 USgal/min].

OLS 320

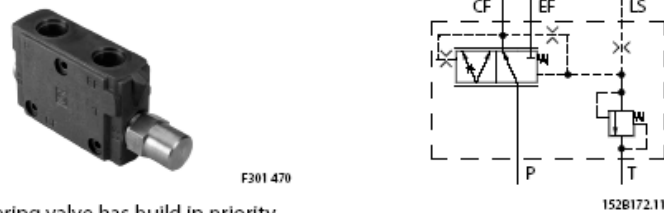

EHPS steering valve has built in priority valve, but for max. pump flow 120 l/min [31.7 USgal/min]. In systems with EHPS and pump flow between 120 l/min [31.7 USgal/min] and 320 l/min [84.5 USgal/min] a combination of EHPS and OLS 320 gives a good compact solution to reduce hosing and installation cost compared with stand alone components. For further details of this OLS 320: look in EHPS catalogue 520L0521.



F301 471



Priority Valves OLSA and OLS

System Sizing

The steering system pump is sized so that satisfactory performance is achieved for both steering and working hydraulics - even at idle.

Before selecting a priority valve, consider

- the type of steering unit (LS static, LS dynamic or OSPF LS dynamic)
- the displacement of the steering unit
- the pump flow
- the application's requirement for energy optimization, initial steering response time and stability, as these all govern the selection for control spring pressure
- whether the priority valve should have internal PP (Pilot Pressure) or external PP-connection depends on the pressure drop in the pump line between the priority valve's CF-port (Controlled Flow) and the steering unit's P-port. With normal hose and tube dimensions and less than 5 m distance between priority valve and steering unit, the immediate choice is normally a priority valve with internal PP.

The following survey lists the code numbers of the priority valves that are the most frequently used in connection with the above Sauer-Danfoss steering unit types. All priority valves in the code number tables, except OLS 160 static, have internal PP connection. OLS 160 static in the code number table all have external PP connection.

Code Numbers and Weights

OLS/OLSA static priority valves for load sensing static steering units

OLSA 40 static and OLSA 80 static

Priority valve	Code Numbers		Control spring pressure bar [psi]	Weight kg [lb]
	Connections			
	European version T, R, L: G 3/8 P, EF: G 1/2	US version T, R, L: 9/16 - 18 UNF P, EF: 7/8 - 14 UNF		
OLSA 40	152B0001	-	4 [58]	2.1 [4.63]
OLSA 40	152B0002	152B0122	7 [101.5]	2.1 [4.63]
OLSA 40	152B0003	152B0124	10 [145]	2.1 [4.63]
OLSA 80	152B0016	152B0019	4 [58]	2.1 [4.63]
OLSA 80	152B0017	152B0020	7 [101.5]	2.1 [4.63]
OLSA80	152B0015	152B0125	10 [145]	2.1 [4.63]

OLS 40 static and OLS 80 static

Priority valve	Code Numbers		Control spring pressure bar [psi]	Weight kg [lb]
	Connections			
	European version LS: G 1/4 P, EF, CF: G 1/2	US version LS: 7/16 - 20 UNF CF: 3/4 - 16 UNF P, EF: 7/8 - 14 UNF		
OLS 40	152B0231	152B0237	4 [58]	1.0 [2.2]
OLS 40	152B0232	152B0238	7 [101.5]	1.0 [2.2]
OLS 40	152B0233	152B0253	10 [145]	1.0 [2.2]
OLS 80	152B0261	152B0267	4 [58]	1.0 [2.2]
OLS 80	152B0262	152B0268	7 [101.5]	1.0 [2.2]
OLS 80	152B0263	152B0280	10 [145]	1.0 [2.2]

Priority Valves OLSA and OLS

Code Numbers and Weights (continued)

OLS/OLSA static priority valves for load sensing static steering units

OLS 120 static

Priority valve	Code Numbers		Control spring pressure bar [psi]	Weight kg [lb]
	Connections			
	European version LS: G 1/4 CF: G 1/2 P, EF: G 3/4	US version LS: 7/16 - 20 UNF CF: 3/4 - 16 UNF P, EF: 1 1/16 - 12 UNF		
OLS 120	152B2232	152B2238	7 [101.5]	2.1 [4.63]
OLS 120	152B2233	152B2239	10 [145]	2.1 [4.63]

OLS 160 static

Priority valve	Code Numbers		Control spring pressure bar [psi]	Pilot pressure relief valve bar [psi]	Weight kg [lb]
	Connections				
	European version LS, PP, T: G 1/4 CF: G 1/2 P, EF: G 3/4	US version LS, PP, T: 7/16 - 20 UNF CF: 3/4 - 16 UNF P, EF: 1 1/16 - 12 UNF			
OLS 160	152B1005	152B1085	7 [101.5]	170 [2465]	4.4 [9.7]
OLS 160	152B1006	152B1086	10 [145]	170 [2465]	4.4 [9.7]

OLS/OLSA dynamic priority valves for load sensing dynamic steering units

OLSA 40 dynamic and OLSA 80 dynamic for OSPC LS dynamic

Priority valve	Code Numbers		Control spring pressure bar [psi]	Weight kg [lb]
	Connections			
	European version T,R,L: G 3/8 P/EF: G 1/2	US version T,R,L: 9/16 - 18 UNF P/EF: 7/8 - 14 UNF		
OLSA 40	152B8001	-	4 [58]	2.1 [4.63]
OLSA 40	152B8041	152B8042	7 [101.5]	2.1 [4.63]
OLSA 40	152B8046	152B8043	10 [145]	2.1 [4.63]
OLSA 80	152B8047	-	4 [58]	2.1 [4.63]
OLSA 80	152B8048	152B8044	7 [101.5]	2.1 [4.63]
OLSA 80	152B8049	152B8045	10 [145]	2.1 [4.63]

Priority Valves OLSA and OLS

Code Numbers and Weights (continued)

OLS/OLSA dynamic priority valves for load sensing dynamic steering units

OLS 40 dynamic and OLS 80 dynamic for OSPB, OSPC, OSPD, OSPQ and OSPL LS dynamic

Priority valve	Code Numbers		Control spring pressure bar [psi]	Weight kg [lb]
	Connections			
	European version LS: G 1/4 P, EF, CF: G 1/2	US version LS: 7/16 - 20 UNF CF: 3/4 - 16 UNF P, EF: 7/8 - 14 UNF		
OLS 40	152B8231	-	4 [58]	1.0 [2.20]
OLS 40	152B8232	152B8253	7 [101.5]	1.0 [2.20]
OLS 40	152B8233	152B8254	10 [145]	1.0 [2.20]
OLS 80	152B8261	-	4 [58]	1.0 [2.20]
OLS 80	152B8256	152B8268	7 [101.5]	1.0 [2.20]
OLS 80	152B8257	152B8260	10 [145]	1.0 [2.20]

OLS 80 dynamic with low pressure drop (P-EF) spool for OSPB, OSPC, OSPD, OSPQ and OSPL LS dynamic

Priority valve	Code Numbers		Control spring pressure bar [psi]	Weight kg [lb]
	Connections			
	European version LS: G 1/4 P, EF, CF: G 1/2			
OLS 80	152B8259		7 [101.5]	1.0 [2.20]

OLS 120 dynamic for OSPB, OSPC, OSPD, OSPQ and OSPL LS dynamic

Priority valve	Code Numbers		Control spring pressure bar [psi]	Weight kg [lb]
	Connections			
	European version LS: G 1/4 CF: G 1/2 P, EF: G 3/4	US version LS: 7/16 - 20 UNF CF: 3/4 - 16 UNF P, EF: 1 1/16 - 12 UNF		
OLS 120	152B8132	152B8143	7 [101.5]	2.1 [4.63]
OLS 120	152B8133	152B8144	10 [145]	2.1 [4.63]

OLS 160 dynamic for OSPB, OSPC, OSPD, OSPQ and OSPL LS dynamic

Priority valve	Code Numbers		Control spring pressure bar [psi]	Pilot pressure relief valve bar [psi]	Weight kg [lb]
	Connections				
	European version LS, T: G 1/4 CF: G 1/2 P, EF: G 3/4	US version LS, T: 1/16 - 20 UNF CF: 3/4 - 16 UNF P, EF: 1 1/16 - 12 UNF			
OLS 160	152B8159	152B8154	7 [101.5]	170 [2465]	4.4 [9.7]
OLS 160	152B8160	152B8155	10 [145]	170 [2465]	4.4 [9.7]
OLS 160	152B8105	-	12 [174]	170 [2465]	4.4 [9.7]
OLS 160	152B8161	152B8156	7 [101.5]	210 [3045]	4.4 [9.7]
OLS 160	152B8162	152B8157	10 [145]	210 [3045]	4.4 [9.7]

Priority Valves OLSA and OLS

Code Numbers and Weights (continued)

OLS dynamic priority valves for OSPF LS dynamic steering units

OLS 40 dynamic and OLS 80 dynamic

Priority valve	Code Numbers	Control spring pressure bar [psi]	Weight kg [lb]
	Connections European version LS: G 1/4 P, EF, CF: G 1/2		
OLS 40	152B8031	10 [145]	1.0 [2.20]
OLS 80	152B8258	7 [101.5]	1.0 [2.20]

OLS 120 dynamic

Priority valve	Code Numbers	Control spring pressure bar [psi]	Weight kg [lb]
	Connections European version LS: G 1/4, CF: G 1/2 P, EF, CF: G 3/4		
OLS 120	152B8147	7 [101.5]	2.1 [4.63]

OLS 160 dynamic

Priority valve	Code Numbers	Control spring pressure bar [psi]	Pilot pressure relief valve bar [psi]	Weight kg [lb]
	Connections European version LS: G 1/4, CF: G 1/2 P, EF, CF: G 3/4			
OLS 160	152B8158	7 [101.5]	none	4.4 [9.7]
OLS 160	152B8113	10 [145]	none	4.4 [9.7]

OLSP static and dynamic

Priority valve	Code Numbers	Control spring pressure bar [psi]	Weight kg [lb]
	Connections European version LS: G 1/4 CF: G 3/8 EF: G 1/2		
OLSP 80 static	152B5002	4 [58]	1.0 [2.2]
OLSP 80 dynamic	152B5200	7 [101.5]	1.0 [2.2]
OLSP 80 dynamic for OSPF	152B5201	7 [101.5]	1.0 [2.2]

Priority Valves OLSA and OLS

OLS Dynamic Priority Valves for OSPF LS Dynamic Steering Units (continued)

OLS 320 dynamic in-line/stand alone with pilot pressure relief valve, black painted

Priority valve	Code Numbers	Control spring pressure bar [psi]	Pilot pressure relief valve bar [psi]	Weight kg [lb]
	Connections European version LS, T: G $\frac{3}{4}$ CF: G $\frac{1}{2}$ P, EF: G 1			
OLS 320	11006593	7 [101.5]	170 [2465]	5.9 [13.0]

OLS 320 dynamic in-line/stand alone without pilot pressure relief valve, black painted

Priority valve	Code Numbers	Control spring pressure bar [psi]	Weight kg [lb]
	Connections US version LS: 7/16 - 20 UNF CF: 11/16 - 12 UN P, EF: 15/16 - 12 UN		
OLS 320	11007475	10 [145]	5.9 [13.0]

OLS 320 for EHPS: look in EHPS catalogue 520L0521

If you require other port connections, other control spring pressure and/or other PP connection, go to the survey on page 50, and tick off the desired specifications, then consult the Sauer-Danfoss Sales Organization.

Priority Valves OLSA and OLS

Specification Table for Non Catalogue Numbers of Sauer-Danfoss Priority Valves

Your company	Name		Vehicle				Potential, pcs/year				Completed by		Date
Your application	Pump flow to OLS/OLSA at idle, l/min [USgal/min]						Pump flow to OLS/OLSA at max. engine speed, l/min [USgal/min]						
Priority valve type	OLSA 40	OLSA 80	OLS 40	OLS 80	OLS 120	OLS 160	OLSP 80	OLS 320 in-line					
Load sensing type	Static		Dynamic				Dynamic for OSPF steering unit						
Spool type	Standard		Low pressure drop, P-EF (only OLS/OLSA 80 dynamic)				No CF cut-off (only for OLS 320 for flanging on EHP5)						
Control spring, bar	4 (only OLS 80, 120, 160, OLSP 80)		5.5 (only OLS/OLSA 40/80)				7	10	12 (only OLS 160)	16 (only OLS 160)			
PP connection	Internal						External (not OLSP)						
Ports, OLSA	G: P, EF: G½ - S** T, L, R: G3/8 - S**		Metric 1: P, EF, T, L, R: M18 • 1.5 - O*** + S**				Metric 2: P, EF: M22 • 1.5 - O*** + S** T, L, R: M18 • 1.5 - O*** + S**		UNF: P, EF: 7/8 - 14 UNF - O*** T, L, R: 9/16 - 18 UNF - O***				
Ports, OLS 40/80	G: P, CF, EF: G½ - S** LS: G½ - S**		Metric: P, EF: M22 • 1.5 - O*** + S** CF: M18 • 1.5 - O*** + S** LS: M12 • 1.5 - O*** + S**				UNF: P, EF: 7/8 - 14 UNF - O*** CF: 3/4 - 16 UNF - O*** LS: 7/16 - 20 UNF - O***						
Ports, OLS 120	G: P, EF: G¾ - S** CF: G½ - S** LS, PP: G¾ - S**		Metric: P, EF: M27 • 2 - O*** + S** CF: M18 • 1.5 - O*** + S** LS: M12 • 1.5 - O*** + S**				UNF: P, EF: 1 1/16 - 14 UNF - O*** CF: 3/4 - 16 UNF - O*** LS: 7/16 - 20 UNF - O***						
Ports, OLS 160	P, EF: G¾ - S** G 1: CF: G½ - S** LS, PP, T: G¾ - S**		P, EF: G1 - S** G 2: CF: G¾ - S** LS, PP, T: G¾ - S**		P, EF: 11/16 - 12 UN - O*** UNF 1: CF: 3/4 - 16 UNF - O*** LS, PP, T: 7/16 - 20 UNF - O***		UNF 2: P, EF: 15/16 - 12 UN - O*** CF: 7/8 - 14 UNF - O*** LS, PP, T: 7/16 - 20 UNF - O***						
Ports, OLSP 80 (P: square flange 35)	G: EF: G½ - S** CF: G3/8 - S** LS: G¾ - S**		Metric: EF: M22 • 1.5 - O*** + S** CF: M18 • 1.5 - O*** + S** LS: M12 • 1.5 - O*** + S**				UNF: EF: 7/8 - 14 UNF - O*** CF: 3/4 - 16 UNF - O*** LS: 7/16 - 20 UNF - O***						
Ports, OLS 320 in-line	G: P, EF: G1 - S** CF: G½ - S** LS, PP: G¾ - S**		UNF 1: P, EF: 1 5/16 - 12 UN - O*** CF: 3/4 - 16 UNF - O*** LS, PP, T: 7/16 - 20 UNF - O***				UNF 2: P, EF: 1 5/16 - 12 UN - O*** CF: 1 1/16 - 12 UNF - O*** LS, PP, T: 7/16 - 20 UNF - O***						
RV-bar OLS 160 OLS 320	80	90	100	110	120	140	170	190	200	210	Other settings		No relief valve
Unit black painted	Yes										No		

Priority Valves OLSA and OLS

Specification Table for Non Catalogue Numbers of Sauer-Danfoss Priority Valves (continued)

Ports: PP-port only exists when external PP connection is used. T-port only exists for OLS 160 and OLS 320 with integrated pilot pressure relief valve (RV)

O*: O-ring chamfer on port connections

S**: Spot face around port connections

An alternative way to specify a variant is to state an existing code number and add the modifications, you would like to have implemented in the basic steering unit.

Code number of basic steering unit: _____

Requested modifications: _____

Technical Data

Max. Pressure on Connections

Priority valve	Rated flow to P-connection		Max. pressure on connections											
	l/min	[US gal/min]	P, EF		CF		L, R		LS		T		PP	
			bar	[psi]	bar	[psi]	bar	[psi]	bar	[psi]	bar	[psi]	bar	[psi]
OLSA 40	40	[10.57]	250	[3625]	210	[3045]	280	[4061]	210	[3045]	20	[290]		
OLSA 80	80	[21.13]	250	[3625]	210	[3045]	280	[4061]	210	[3045]	20	[290]		
OLS 40	40	[10.57]	250	[3625]	210	[3045]			210	[3045]			210	[3045]
OLS 80	80	[21.13]	250	[3625]	210	[3045]			210	[3045]			210	[3045]
OLS 120	120	[31.70]	250	[3625]	210	[3045]			210	[3045]			210	[3045]
OLS 160	160	[42.27]	350	[5076]	210	[3045]			210	[3045]	15	[217]	210	[3045]
OLSP 80	80	[21.13]	250	[3625]	210	[3045]			210	[3045]				
OLS 320	320	[84.54]	300	[4351]	280	[4061]			280	[4061]	40	[580]	280	[4061]

Priority Valves OLSA and OLS

Pressure Drop in Priority Valves

Pressure drop in priority valves

This data comes from measurements on a representative sample of priority valves from production. Oil with viscosity of 21 mm²/s at 50 °C [102 SUS at 122 °F] was used during measuring. Measurement made when pressure on the LS connection is zero (steering unit in neutral position). The minimum curves apply when the pressure on the EF connection is higher than the actual control spring pressure. The curves for control spring pressure of 4, 7, 10 or 12 bar [58, 101, 145 or 174 psi] apply when pressure on the EF connection is zero.

Pressure drop P-EF for static priority valves

OLSA/OLS 40

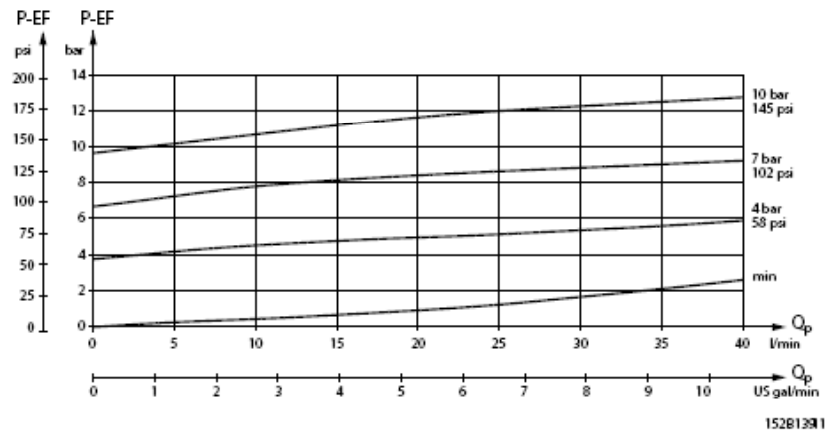

OLSA/OLS 80

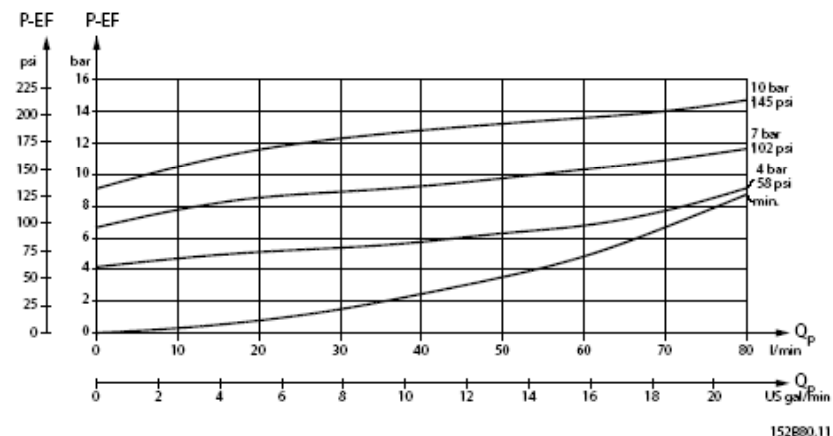

Priority Valves OLSA and OLS

Technical Data

Pressure drop P-EF for static priority valves

OLS 120

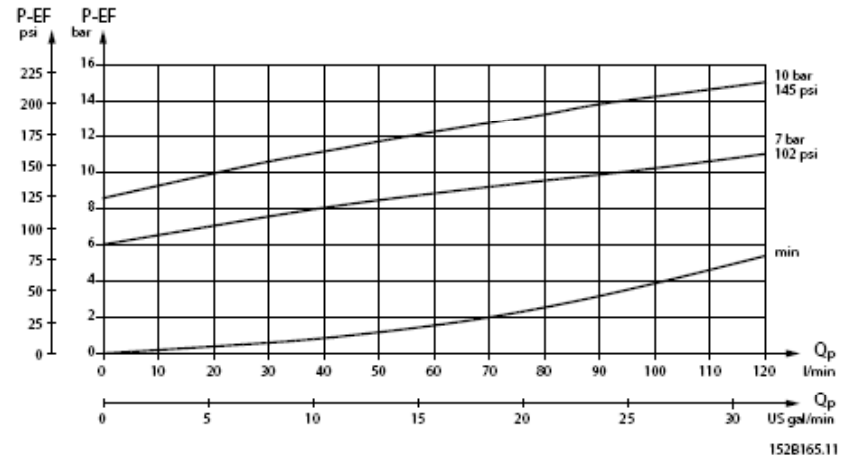

OLS 160

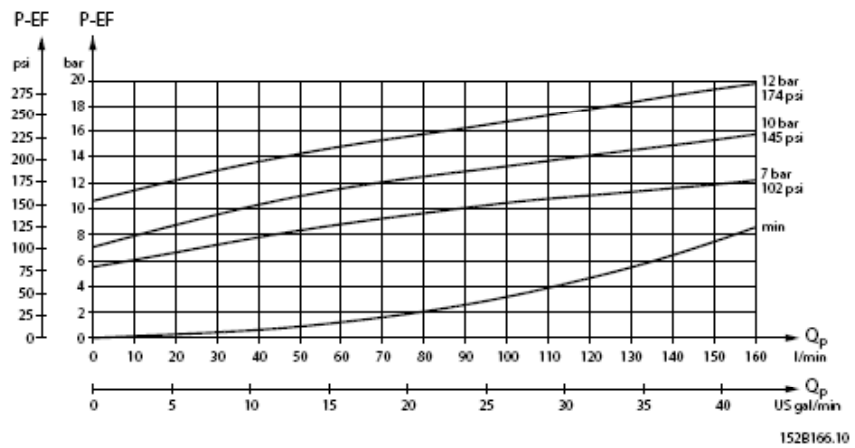

Priority Valves OLSA and OLS

Technical Data (continued)

Pressure drop P-EF for dynamic priority valves

OLSA/OLS 40

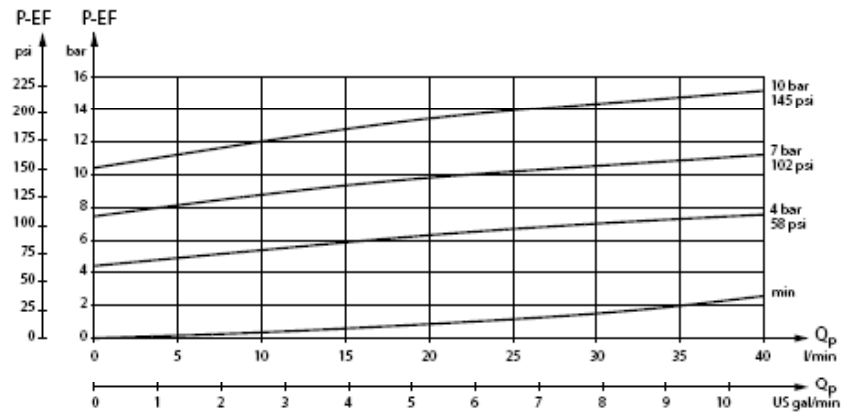

1528174.10

OLSA/OLS 80

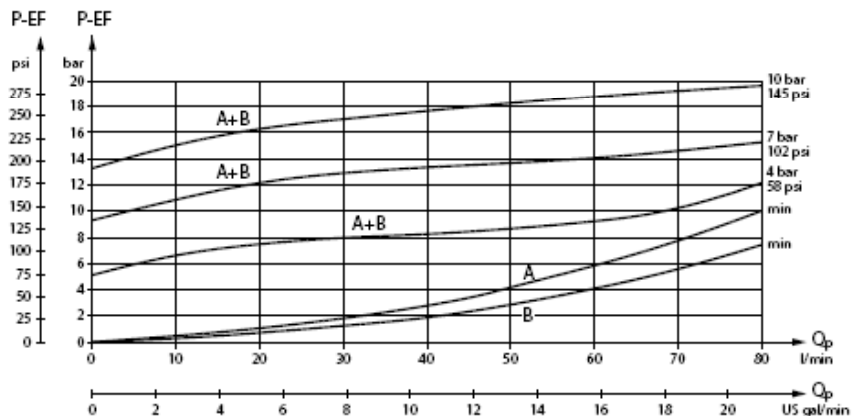

1528175.10

A: OLS/OLSA 80 Dynamic for OSPB, OSPC, OSPF, OSPD, OSPQ, OSPL LS Dynamic

B: OLS/OLSA 80 Dynamic with low pressure drop (P-EF) spool for OSPB, OSPC, OSPD, OSPQ, OSPL LS Dynamic

Priority Valves OLSA and OLS

Technical Data (continued)

Pressure drop P-EF for dynamic priority valves

OLS 120

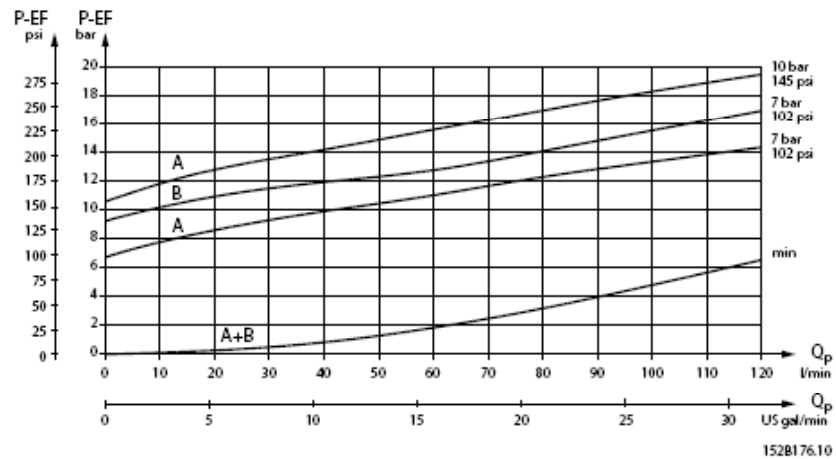

A: OLS 120 Dynamic for OSPB, OSPC, OSPD, OSPQ, OSPL LS Dynamic

B: OLS 120 Dynamic for OSPF LS Dynamic

OLS 160

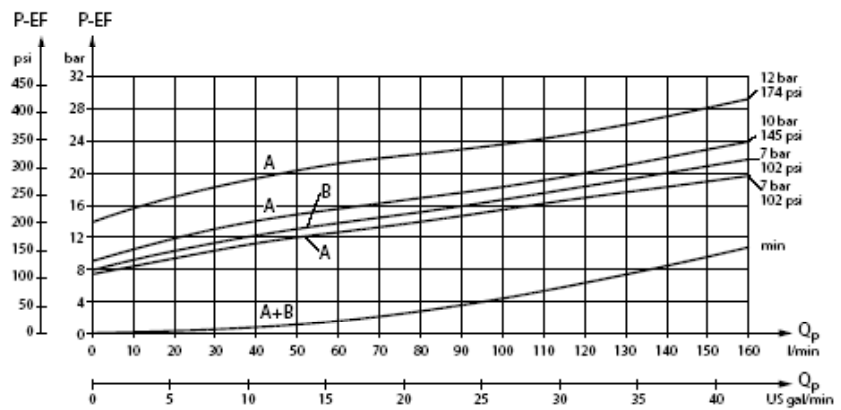

A: OLS 160 Dynamic for OSPB, OSPC, OSPD, OSPQ, OSPL LS Dynamic

B: OLS 160 Dynamic for OSPF LS Dynamic

Priority Valves OLSA and OLS

Technical Data (continued)

Pressure drop P-EF for OLSP static priority valves

OLSP 80

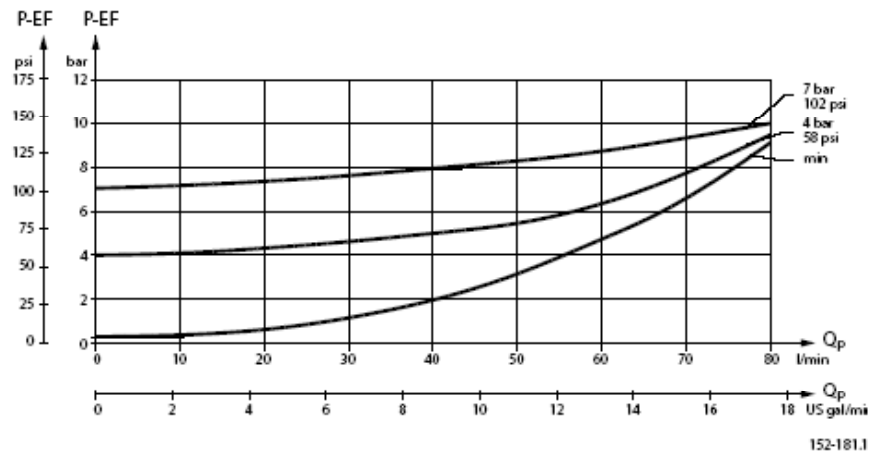

Pressure drop P-EF for OLSP dynamic priority valves

OLSP 80

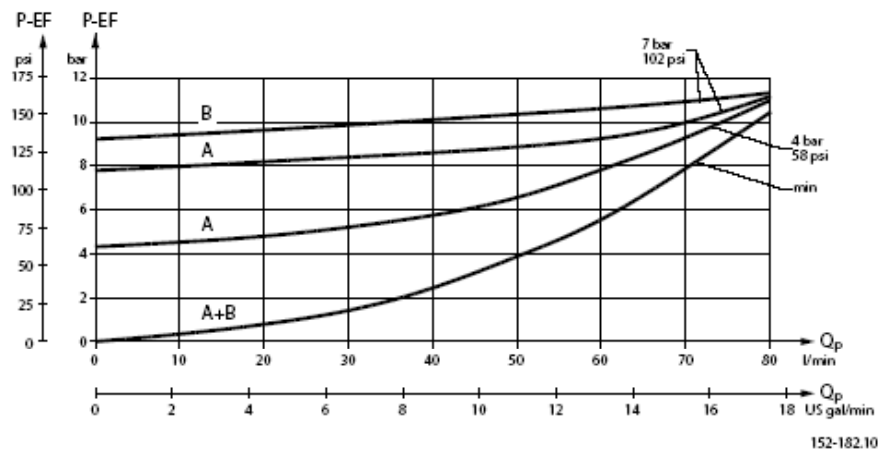

A: OLSP 80 dynamic for OSPB, OSPC, OSPD, OSPQ LS dynamic

B: OLSP 80 dynamic for OSPF LS dynamic

Priority Valves OLSA and OLS

Technical Data (continued)

Pressure drop P-EF for OLS 320 static priority valves

OLS 320

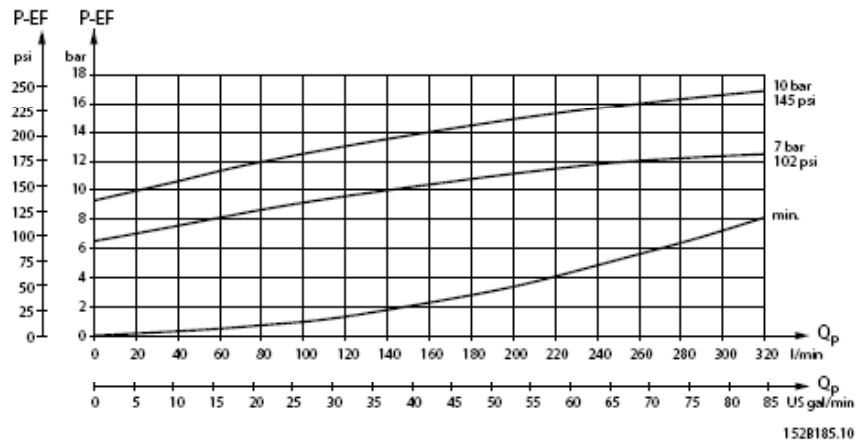

Pressure drop P-EF for OLS 320 dynamic priority valves

OLS 320

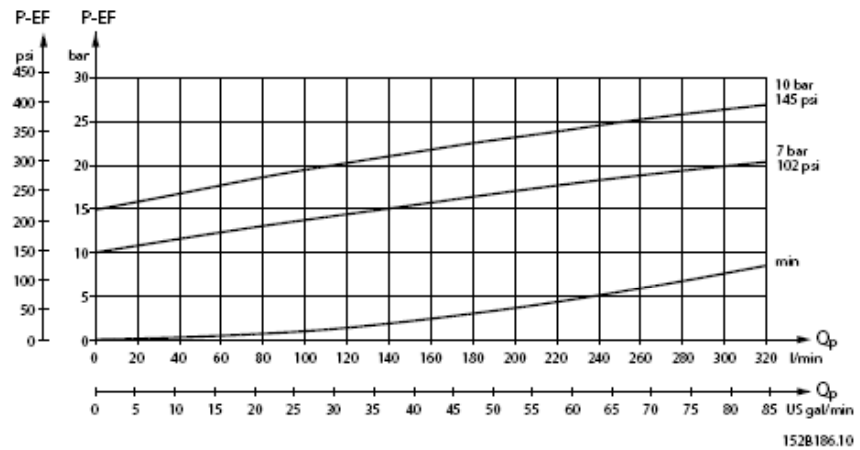

Priority Valves OLSA and OLS

Technical Data (continued)

OLS 160, pilot pressure relief valve (P - T, Q_p) characteristic

OLS 160 with pilot pressure relief valve is used in connection with Sauer-Danfoss steering units without pilot pressure relief valve, normally steering unit type OSPL. The pilot pressure relief valve protects the steering unit against excessive pressure. The pilot pressure relief valve in OLS 160 operates with the priority valve spool in the OLS 160 to limit the maximum steering pressure P-T measured across the steering unit ports. The pilot pressure relief valve is set when an oil flow of 80 l/min [21 US gal/min] is supplied to OLS 160.

Setting tolerance:

rated value +10 bar [145 psi]

OLS 160

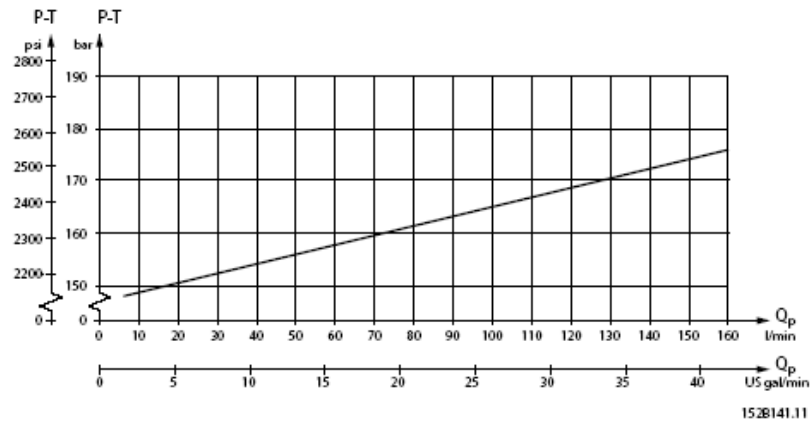

1520141.11

Q_p = Pump flow

OLS 320

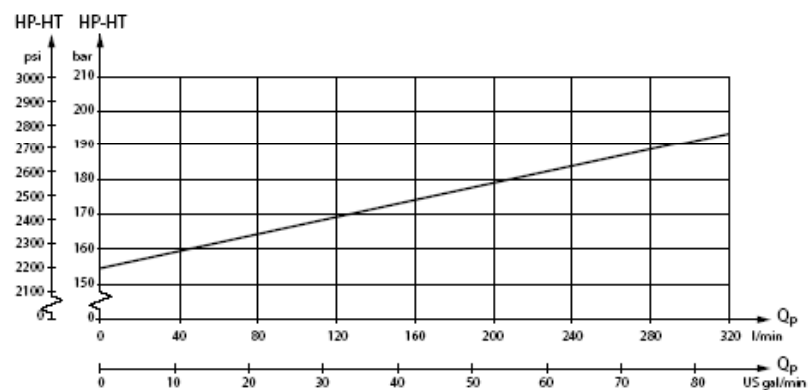

1520187.10



Priority Valves OLSA and OLS

Dimensions

OLSA

European version:

P, EF:

G $\frac{1}{2}$ w. spot face
 14 mm [0.55 in] deep
 x = 34 mm [1.34 in],
 max. 1.5 mm [0.06 in] deep
 or M18 x 1.5 ISO 6149
 14,5 mm [0.57 in] deep
 x = 29 mm [1.14 in],
 max. 1.5 mm [0.06 in] deep
 or M22 x 1.5 ISO 6149,
 15,5 mm [0.61 in] deep
 x = 34 mm [1.34 in],
 max. 1.5 mm [0.06 in] deep

T, L, R:

G $\frac{3}{8}$ w. spot face
 12 mm [0.47 in] deep
 y = 34 mm [1.34 in],
 max. 1.5 mm [0.06 in] deep
 or M18 x 1.5 ISO 6149,
 15 mm [0.59 in] deep
 y = 29 mm [1.14 in],
 max. 1.5 mm [0.06 in] deep

US version:

P, EF:

$\frac{7}{8}$ -14 UNF O-ring boss
 16.7 mm [0.66 in] deep
 x = 34 mm [1.34 in],
 max. 1.5 mm [0.06 in] deep

T, L, R:

$\frac{5}{16}$ -18 UNF O-ring boss
 12.7 mm [0.50 in] deep
 y = 25 mm [0.98 in],
 max. 1.5 mm [0.06 in] deep

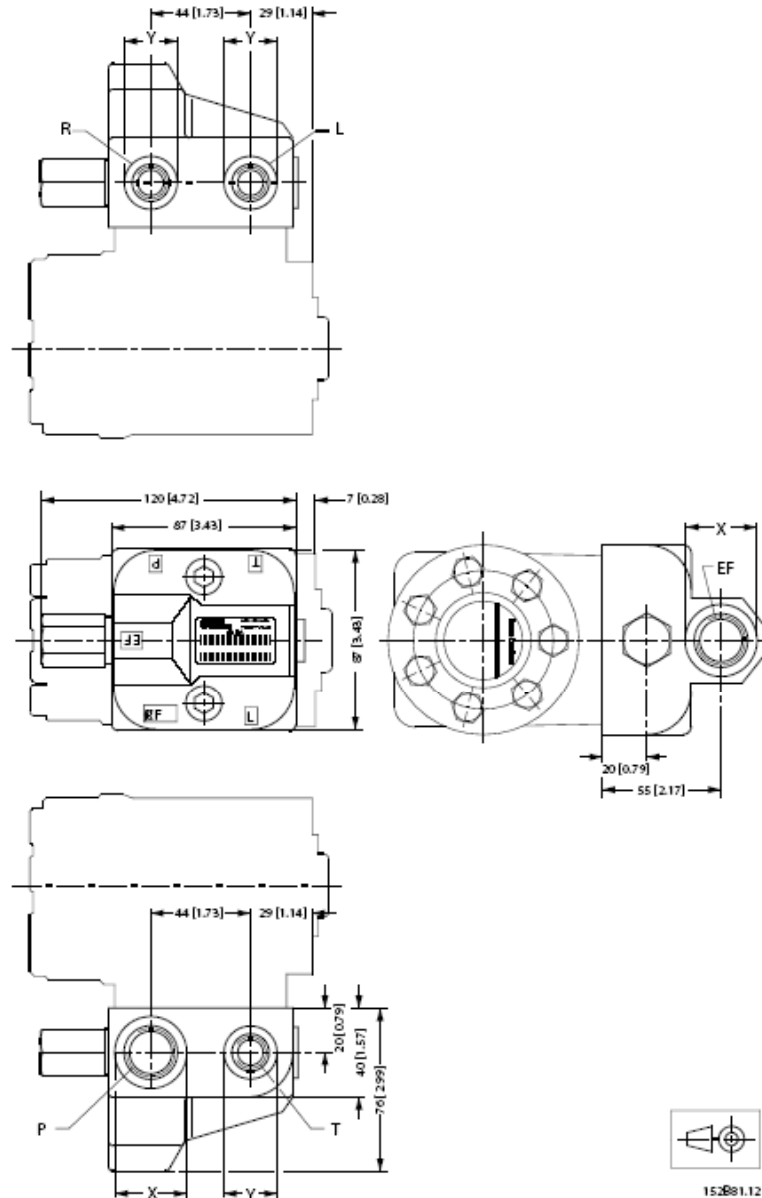

Priority Valves OLSA and OLS

Dimensions

OLS 40, OLS 80

European version:

P, EF:

G ½ w. spot face
15 mm [0.59 in] deep
x = 29 mm [1.14 in],
max. 1.5 mm [0.06 in] deep
or M22 x 1,5 ISO 6149
15 mm [0.59 in] deep,
x = 34 mm [1.34 in],
max. 1 mm [0.04 in] deep

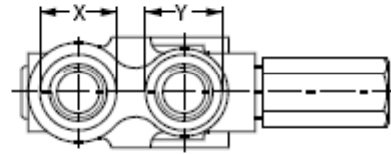

CF:

G ½ w. spot face
14 mm [0.55 in] deep
y = 29 mm [1.14 in],
max. 1.5 mm [0.06 in] deep
or M18 x 1,5 ISO 6149
12 mm [0.47 in] deep,
y = 29 mm [1.14 in],
max. 1 mm [0.04 in] deep



LS:

G ¼ w. spot face
12.5 mm [0.49 in] deep
z = 21 mm [0.83 in],
max. 1 mm [0.04 in] deep
or M12 x 1,5 ISO 6149
12,5 mm [0.49 in] deep,
z = 22 mm [0.86 in]
0 mm deep

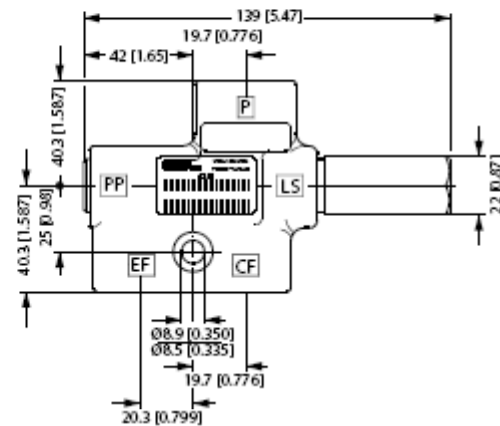

US version:

P, EF:

7/8 - 14 UNF O-ring boss
15 mm [0.59 in] deep
x = 34 mm [1.14 in],
max. 1.3 [0.05] deep

CF:

¾ - 16 UNF O-ring boss
14,3 mm [0.56 in] deep
y = 30 mm [1.18 in],
max. 1.3 mm [0.05 in] deep

LS:

7/16-20 UNF O-ring boss
12.5 mm [0.49 in] deep
z = 21 mm [0.83 in],
max. 1 mm [0.04 in] deep

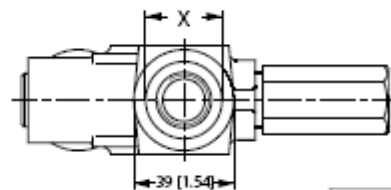

152B136.11

Priority Valves OLSA and OLS

Dimensions

OLS 120

European version:

P, EF:

G $\frac{3}{4}$ w. spot face
 $x = 42 \text{ mm}$ [1.65 in],
 max. 2.5 mm [0.10 in] deep
 or M27 x 2 ISO 6149
 $x = 40 \text{ mm}$ [1.57 in],
 max. 2.5 mm [0.10 in] deep

CF:

G $\frac{1}{2}$ w. spot face
 $y = 34 \text{ mm}$ [1.34 in],
 max. 2.5 mm [0.10 in] deep
 or M18 x 1.5 ISO 6149
 $y = 29 \text{ mm}$ [1.14 in],
 max. 2.5 mm [0.10 in] deep

LS, PP:

G $\frac{1}{4}$ w. spot face
 12 mm [0.47 in] deep
 $z = 19 \text{ mm}$ [0.75 in]
 0 mm deep
 or M12 x 1.5 ISO 6149
 11.5 mm [0.45 in] deep,
 $z = 19 \text{ mm}$ [0.75 in]
 0 mm deep

US version:

P, EF:

1 $\frac{1}{16}$ - 12 UN O-ring boss
 $x = 41 \text{ mm}$ [1.61 in],
 max. 1.5 mm [0.06 in] deep

CF:

$\frac{3}{4}$ - 16 UNF O-ring boss
 $y = 30 \text{ mm}$ [1.18 in],
 max. 1.5 mm [0.06 in] deep

LS, PP:

$\frac{7}{16}$ - 20 UNF O-ring boss
 11.5 mm [0.45 in] deep
 $z = 19 \text{ mm}$ [0.75 in] 0 mm
 deep

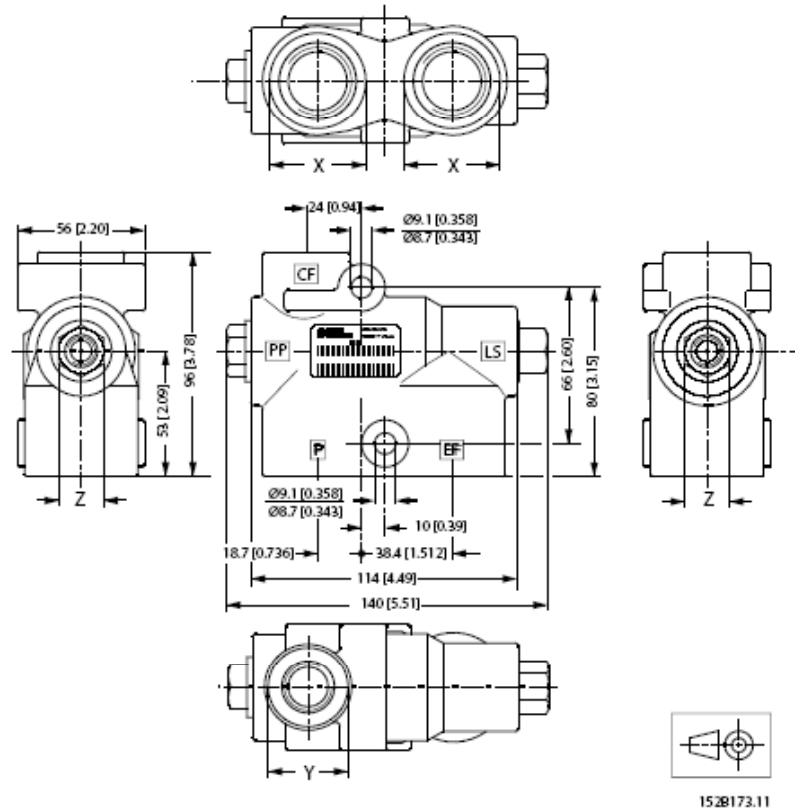

Priority Valves OLSA and OLS

Dimensions

OLS 160

European version:

P, EF:

G 3/4 w. spot face
 $x = 42 \text{ mm}$ [1.65 in]
 max. 2.5 mm [0.10 in] deep
 or G 1 w. spot face
 $x = 47 \text{ mm}$ [1.85 in]
 max. 2.5 mm [0.10 in] deep

CF:

G 1/2 w. spot face
 $y = 34 \text{ mm}$ [1.34 in]
 max. 2.5 mm [0.10 in] deep
 or G 3/4 w. spot face
 $y = 38 \text{ mm}$ [1.50 in]
 max. 2.5 mm [0.10 in] deep

LS, PP, T:

G 3/4 w. spot face
 12 mm [0.47 in] deep
 $z = 22.8 \text{ mm}$ [0.89 in]
 max. 1 mm [0.04 in] deep
 $u = 25 \text{ mm}$ [0.98 in]
 max. 1.5 mm [0.06 in] deep

US version:

P, EF:

1 1/16-12 UNF O-ring boss
 $x = 41 \text{ mm}$ [1.61 in]
 max. 2.5 mm [0.10 in] deep
 or 1 1/16 - 12 UNF O-ring boss
 $x = 49 \text{ mm}$ [1.93 in]
 max. 2.5 mm [0.10 in] deep

CF:

3/4-16 UNF O-ring boss
 $y = 32 \text{ mm}$ [1.26 in]
 max. 2.5 mm [0.10 in] deep
 7/8 - 14 UNF O-ring boss
 $y = 30 \text{ mm}$ [1.18 in]
 max. 2.5 mm [0.10 in] deep

LS, PP, T:

7/16 - 20 UNF O-ring boss
 11.5 mm [0.45 in] deep
 $z = 22.8 \text{ mm}$ [0.89 in]
 max. 1.5 mm [0.06 in] deep
 $u = 21 \text{ mm}$ [0.83 in]
 max. 1.6 mm [0.06 in] deep

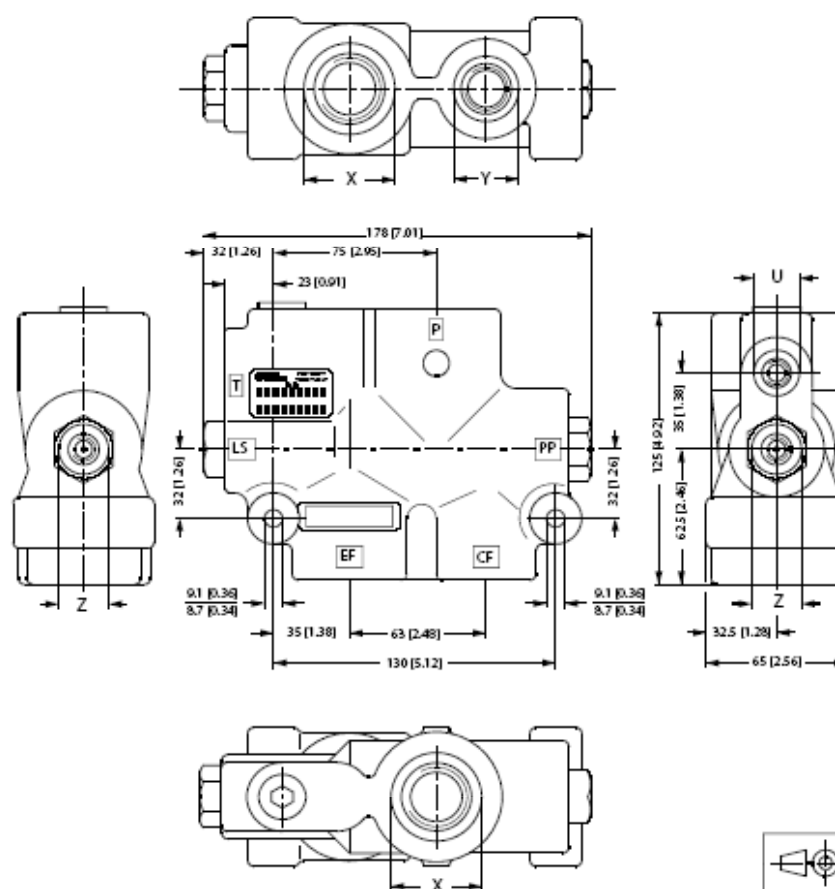

Priority Valves OLSA and OLS

Dimensions

OLSP 80

European version:

CF:

G^{3/8} w. spot face
15 mm [0.59 in] deep
x = $\varnothing 28$, max. 1.5 mm [0.06 in] deep
or
M18 - 1.5 ISO 6149
15 mm [0.59 in] deep
y = $\varnothing 29$, max. 1.5 mm [0.06 in]

EF:

G^{1/2} w. spot face
15 mm [0.59 in] deep
y = $\varnothing 34$, max. 1.5 mm [0.06 in]
or
M22 - 1.5 ISO 6149
15 mm [0.59 in] deep
x = $\varnothing 34$, max. 1.5 mm [0.06 in]

LS:

G^{1/4} w. spot face
12.5 mm [0.49 in] deep
or
M12 - 1.5 ISO 6149
12.5 mm [0.49 in] deep

US version:

CF:

3/4-16 UNF O-ring boss
15 mm [0.59 in] deep
x = $\varnothing 29$ [1.14 in]
max. 1.5 mm [0.06 in] deep

EF:

7/8 - 14 UNF O-ring boss
16.7 mm [0.66 in] deep
y = $\varnothing 34$ [1.34 in]
max. 1.5 mm [0.06 in] deep

LS:

7/16 - 20 UNF O-ring boss
12.5 mm [0.49 in] deep

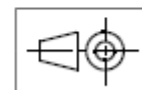
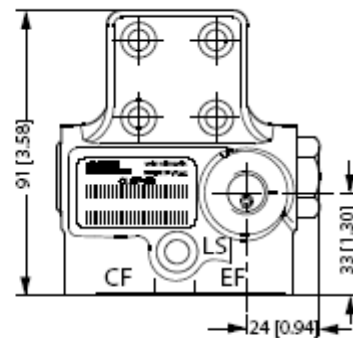
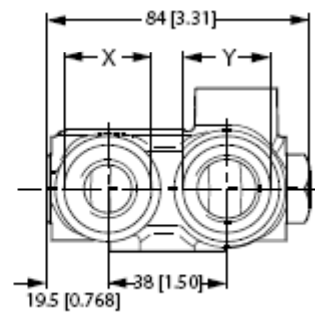
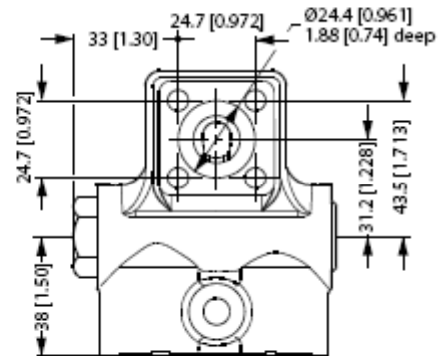

152-180.11



Priority Valves OLSA and OLS

Dimensions

OLS 320 in-line

European version:

P, EF:

G 1 w. spot face
 $x = \varnothing 47 \text{ mm [1.85 in]}$
 max 1 mm [0.04 in] deep

CF:

G ½ w. spot face
 $y = \varnothing 34 \text{ mm [1.34 in]}$
 max 2.5 mm [0.10 in] deep

LS, PP:

G ¼ w. spot face

T:

G ¼ w. spot face
 $z = \varnothing 25 \text{ mm [0.98 in]}$
 max 1.5 mm [0.06 in] deep

US version:

P, EF:

1 5/16-12 UN O-ring boss
 $x = \varnothing 49 \text{ mm [1.93 in]}$
 max 0.2 mm [0.01 in] deep

CF:

1 1/16-12 UN O-ring boss
 $y = \varnothing 41 \text{ mm [1.61 in]}$
 max 0.2 mm [0.01 in] deep
 or
 3/4-16UNF O-ring boss
 $y = \varnothing 30 \text{ mm [1.18 in]}$
 max 0.2 mm [0.01 in] deep

LS, PP, T:

7/16-20 UNF O-ring boss

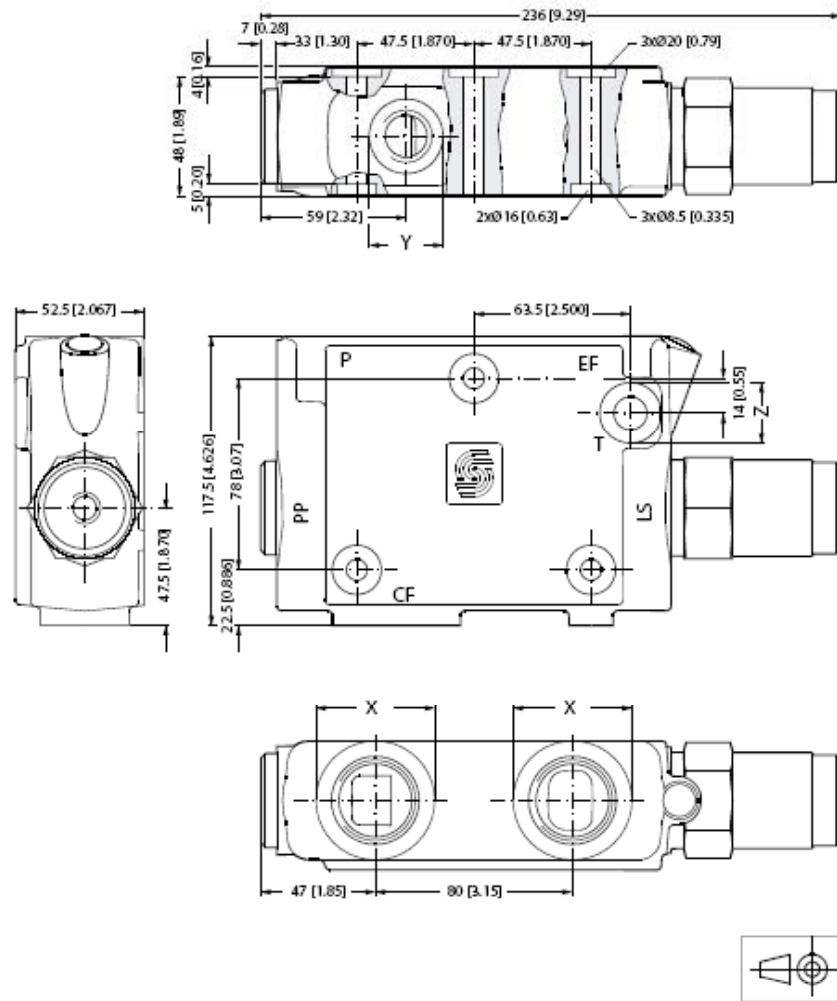

150H26.10

Flow Amplifiers OSQA, OSQB and OSQB/OLSQ

Versions

OSQA and OSQB static

Flow amplifier OSQ is used in steering systems of large vehicles and vessels that need high oil flow for their steering. A steering system of this nature consists of a steering unit and a flow amplifier.



F300630

OSQA static

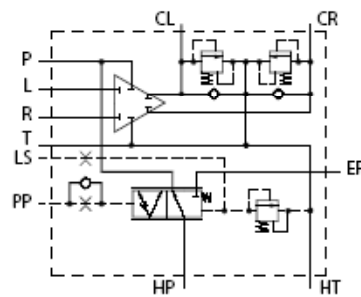

OSQB static

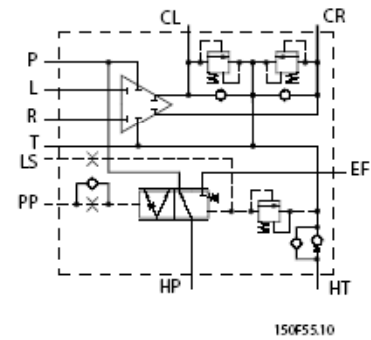

150F55.10

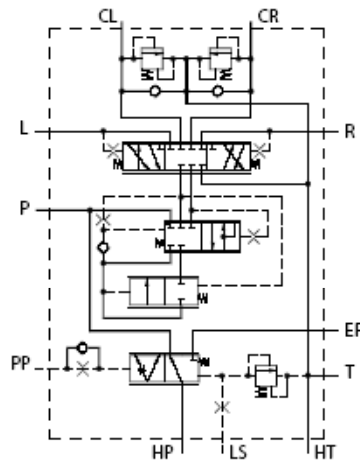

150F80

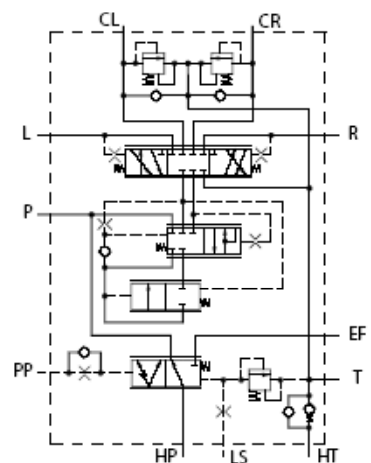

150F54.10

Flow Amplifiers OSQA, OSQB and OSQB/OLSQ

Versions

OSQB dynamic with OLSQ priority valve for emergency steering



E301 256

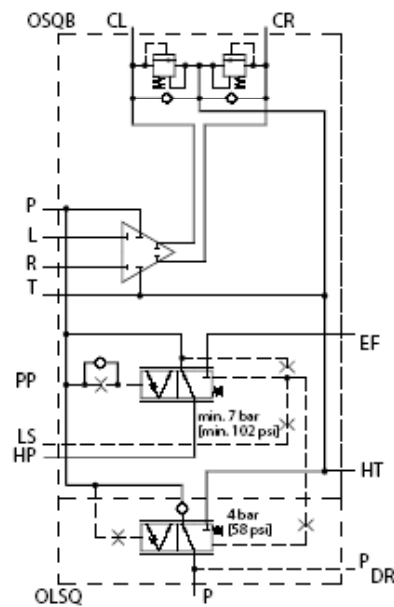

150F74.11

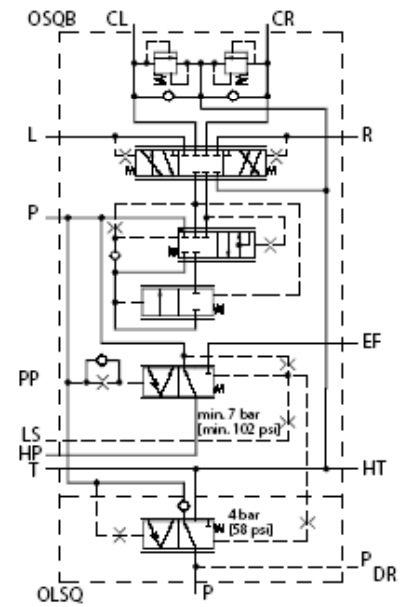

150F73.1

Flow Amplifiers OSQA, OSQB and OSQB/OLSQ

Code Numbers and Weights

OSQA and OSQB static flow amplifiers for load sensing static steering units

These flow amplifiers have to be used in connection with steering units type OSPBX LS or OSPLX LS.

Flow amplifier	Code Numbers		Setting pressures		Control spring pressure bar [psi]	Weight kg [lb]
	Connections: see "dimensions"		Pilot pressure relief valve bar [psi]	Shock valves bar [psi]		
	European version	US version				
OSQA 4	150F0040	150F0043	170 [2465]	230 [3335]	7 [101]	29 [64]
OSQA 5	150F0041	150F0044	170 [2465]	230 [3335]	7 [101]	29 [64]
OSQA 8	150F0042	150F0045	170 [2465]	230 [3335]	7 [101]	29 [64]
OSQB 4	150F0030	150F0053	170 [2465]	230 [3335]	7 [101]	29 [64]
OSQB 5	150F0031	150F0054	170 [2465]	230 [3335]	7 [101]	29 [64]
OSQB 8	150F0032	150F0055	170 [2465]	230 [3335]	7 [101]	29 [64]
OSQB 10	-	150F0094	170 [2465]	260 [3770]	7 [101]	29 [64]

OSQB/OLSQ dynamic flow amplifier for load sensing dynamics steering units.

OSQB with OLSQ has no pilot pressure relief valve.

This flow amplifier has to be used in connection with steering unit type OSPCX LS, which has incorporated pilot pressure relief valve

Flow amplifier	Code Numbers	Setting pressures	Control spring pressure bar [psi]	Weight kg [lb]
	Connections see "dimensions" European version	Shockvalves bar [psi]		
OSQB 8/OLSQ	150F8010	260 [3770 psi]	7 [101.5]	32 [70.6]

If you require other amplification factors, other valve settings or other control spring pressures, please fill in the order form on page 68 and contact the Sauer-Danfoss Sales Organization.

Flow Amplifiers OSQA, OSQB and OSQB/OLSQ

Specification Table for Non Catalogue Numbers of Sauer-Danfoss Flow Amplifiers

Fill in your company data and place x's in the table where appropriate, then send to your Sauer-Danfoss Sales Organization

Your company	Name	Vehicle	Potential pcs/year	Completed by	Date	
Your application	Pump flow to OSQ at idle, l/min [US gal/min]		Pump flow to OSQ at max engine speed, l/min [US gal/min]			
Flow amplifier type	OSQA	OSQB	OSQB/OLSQ			
Amplification factor	4	5	8	9.1	16.5	
Load sensing type	Static		Dynamic			
Control spring bar	7 [101]	10 [145]		16 [232]		
PP-connection	Internal		External			
Ports, OSQA	G: European version HP, EF, HT, CL, CR: G 3/4 P, T, L, R: G 1/2 PP, LS: G 1/4		UNF: US version HP, EF, HT, CL, CR: 1 1/16 - 12 UN P, T, L, R: 3/4 - 16 UNF PP, LS: 7/16 - 20 UNF			
Ports, OSQB	G: European version HP, EF: 1 1/4 in SAE flange HT, CL, CR: 1 in SAE flange P, T, L, R: G 1/2 PP, LS: G 1/4		UNF: US version HP, EF: 1 1/4 in SAE flange HT, CL, CR: 1 in SAE flange P, T, L, R: 3/4 - 16 UNF PP, LS: 7/16 - 20 UNF			
Ports, OSQB/OLSQ	G: (European version) HP, EF: 1 1/4 in SAE flange HT, CL, CR: 1 in SAE flange POSQ, POLSQ, T, L, R: G 1/2 PP, LS: G 1/4					
Pilot pressure relief valve bar [psi]	100 [1450]	120 [1740]	140 [2030]	170 [2465]	210 [3045]	No relief valve (only OSQB/OLSQ)
Shock valves, bar [psi]	165 [2393]	200 [2900]	230 [3335]	260 [3770]	270 [3916]	
Back pressure valve	Yes (Only OSQB)		No			
Unit black painted	Yes		No			

An alternative way to specify a variant is to state an existing code number and add the modifications, you would like to have implemented in the basic flow amplifier.

Code number of basic flow amplifier: _____

Requested modifications: _____



Flow Amplifiers OSQA, OSQB and OSQB/OLSQ

Technical Data

Flow and Pressure

Flow amplifier	Rated flow to HP-connection l/min [US gal/min]	Max. pressure on connections			
		HP, EF, CL CR bar [psi]	LS, PP, P, L, R bar [psi]	HT bar [psi]	T bar [psi]
OSQA	240 [63.4]	280 [4061]	210 [3045]	15 [217.5]	15 [217.5]
OSQB	400 [106]	280 [4061]	210 [3045]	10 [145]	15 [217.5]

Total Displacement of Steering System

Flow amplifier	Amplification factor	Steering unit						
		OSPBX/OSPCX LS				OSPLX LS		
		160 cm ³ /rev [In ³ /rev]	200 cm ³ /rev [In ³ /rev]	315 cm ³ /rev [In ³ /rev]	400 cm ³ /rev [In ³ /rev]	520 cm ³ /rev [In ³ /rev]	630 cm ³ /rev [In ³ /rev]	800 cm ³ /rev [In ³ /rev]
OSQA 4	4	640 [39]	800 [49]	1260 [77]	1600 [98]	2080 [127]		
OSQA 5	5	800 [49]	1000 [61]	1575 [96]	2000 [122]			
OSQA 8	8	1280 [78]	1600 [98]					
OSQA 10	9.1	1456 [89]						
OSQB 4	4					2080 [127]	2520 [154]	3200 [195]
OSQB 5	5				2000 [122]	2600 [159]	3150 [192]	4000 [244]
OSQB 8	8			2520 [154]	3200 [195]	4160 [254]		
OSQB 10	9.1		1820 [111]	2865 [175]	3640 [222]			
OSQB 20	16.5	2640 [161]	3300 [201]					

Installation

The flow amplifier has to be mounted on a flat surface.

Mounting screw	Tightening torque, Nm [lbf.in]
M 10 x 1.5	30 ±5 [265 ±44]
3/8 - 16 UNC	40 ±5 [354 ±44]
7/16 - 14 UNC	55 ±5 [487 ±44]

Tightening torque for fittings: Look in sub catalogue "General Steering Components" page 36.

Flow Amplifiers OSQA, OSQB and OSQB/OLSQ

Technical Data

Valve functions in the flow amplifiers

The datas below come from measurements on a representative sample of flow amplifier: from production. Oil with viscosity of 21 mm²/s [102 SUS] at 50 °C [122 °C] was used during measuring.

Priority valve

The priority valve is used in load sensing systems where the same pump supplies oil to both the steering system and working hydraulics. The steering system always has first priority. Measurements were made when the pressure on the LS connection is zero. (steering unit is in neutral position). The minimum curves apply when the pressure on the EF connection is higher than the actual control spring pressure. The curves for control spring pressure of 7 bar [101.5 psi] apply when the pressure on the EF connection is zero

OSQA

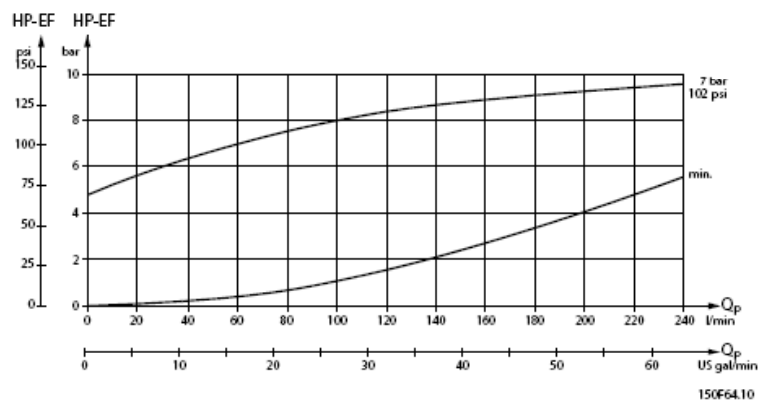

OSQB

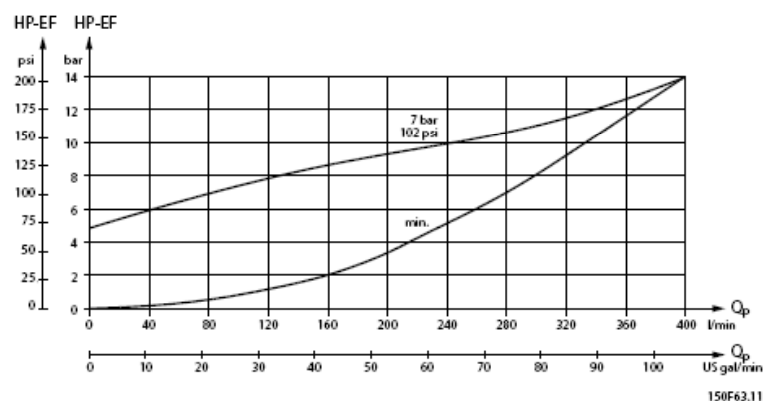

Flow Amplifiers OSQA, OSQB and OSQB/OLSQ

Technical Data

OSQ pilot pressure relief valve (HP - HT, Q_p) characteristic

The pilot pressure relief valve protects the steering unit against excessive pressure. The pilot pressure relief valve together with the priority valve limit the maximum steering pressure HP-HT.

The pilot pressure relief valve in OSQ is set with an oil flow of 140 l/min [37 US gal/min] supplied to the HP connection.

Setting tolerance: rated value +10 bar [+145 psi]. The curves below are valid for rated settings 170 bar [2466 psi].

OSQA

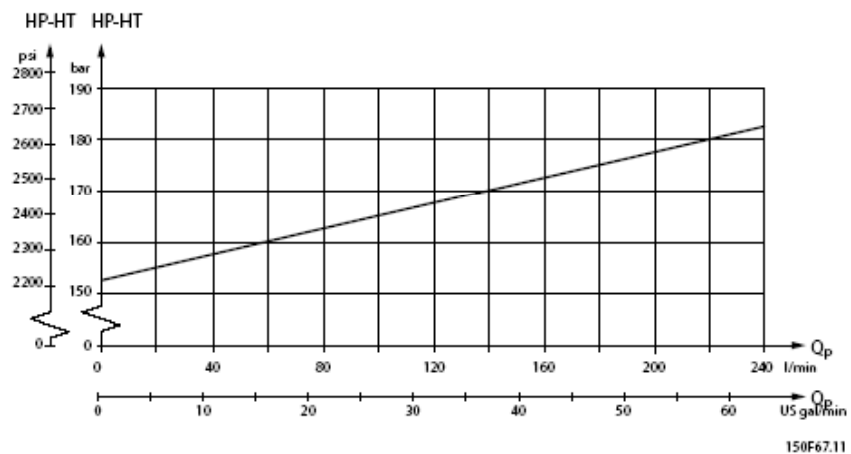

OSQB

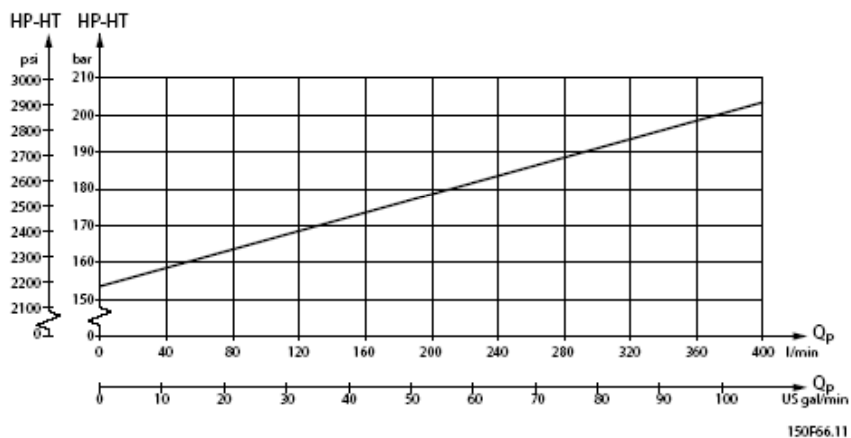

Flow Amplifiers OSQA, OSQB and OSQB/OLSQ

Technical Data

Back pressure valve

The back pressure valve in (OSQB only) increases the capacity of the suction valves. The pressure drop shown applies to the back pressure valve only.

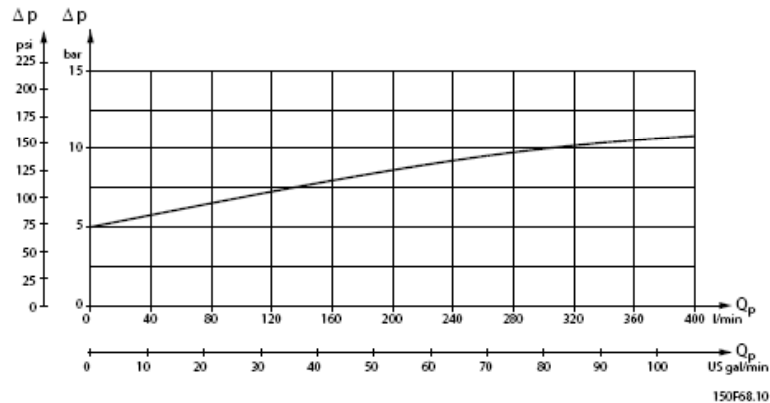

Shock valves

The shock valves protect the flow amplifier against shock from external forces on the steering cylinders. The shock valves in OSQA and OSQB limit the maximum pressure drop from CL to HT and from CR to HT. The shock valves are set at 10 l/min [2.64 US gal/min].

Setting tolerance: rated value +20 bar [290 psi].

Suction valves

The suction valves ensure oil suction on the side of the steering cylinder pistons where in unfavorable conditions cavitation might occur. The capacity of the suction valves is increased in OSQB by the built-in back pressure valve.

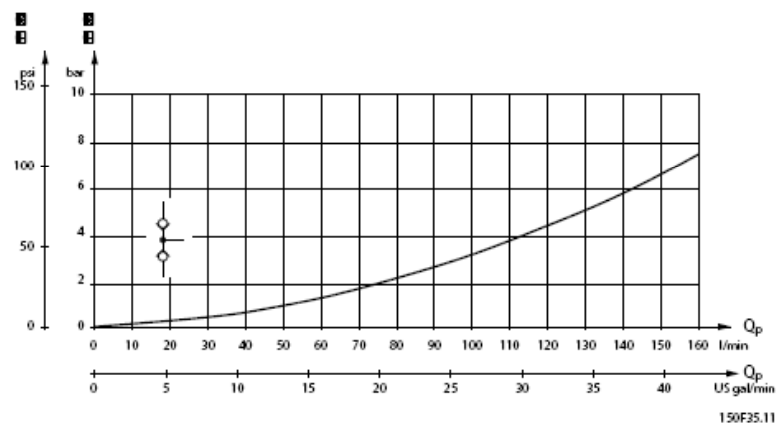

Flow Amplifiers OSQA, OSQB and OSQB/OLSQ

Technical Data

Priority valve OLSQ for emergency circuit in OSQB/OLSQ

When under normal steering conditions the stand-by pressure in the main circuit (minimum 7 bar [101.5 psi] priority valve spring in OSQ) overrules the spring pressure in OLSQ (4 bar [58 psi] spring), OLSQ's priority valve will pass oil from the emergency steering pump across OLSQ's P-connection to the flow amplifier's HT tank connection. If the oil supply from the main pump should fail, the stand-by pressure of OSQ's priority valve in the main pump circuit disappears and relocates the spool in OLSQ to enable the oil from the emergency steering pump to enter the pump circuit in the OSQ. The curve shows the pressure drop from OLSQ's P-connection to OSQ's HT-connection with an active main pump and neutral positioned steering. The curve solely applies to OSQs without any back pressure valve in the tank line.

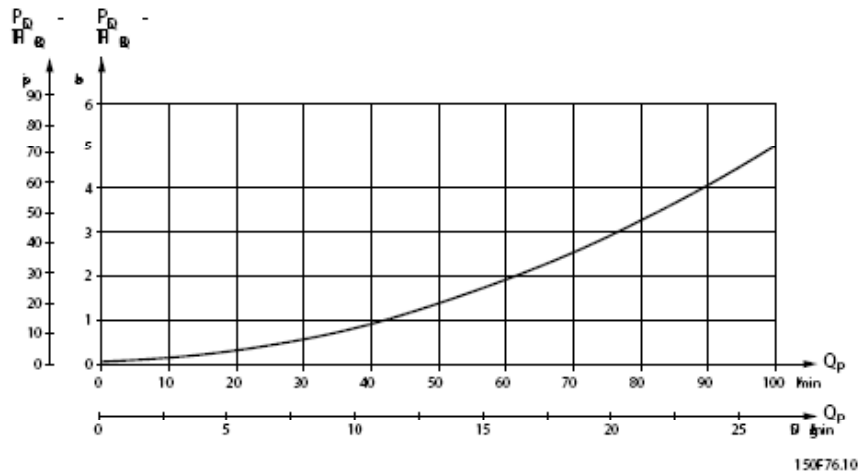

Flow Amplifiers OSQA, OSQB and OSQB/OLSQ

Dimensions OSQA

European version:
 HP, EF, HT, CL, CR: G 3/4
 P, T, L, R: G 1/2
 PP, LS: G 1/4

A: M10 x 1.5, 21 mm [0.83 in] deep
 B: M10 x 1.5, 16 mm [0.63 in] deep

US version:
 HP, EF, HT, CL, CR: 1 1/16 - 12 UN
 P, T, L, R: 3/4 - 16 UNF
 PP, LS: 7/16 - 20 UNF

A:
 7/16 - 14 UNC, 21 mm [0.83 in] deep
 B:
 7/16 - 14 UNC, 16 mm [0.63 in] deep

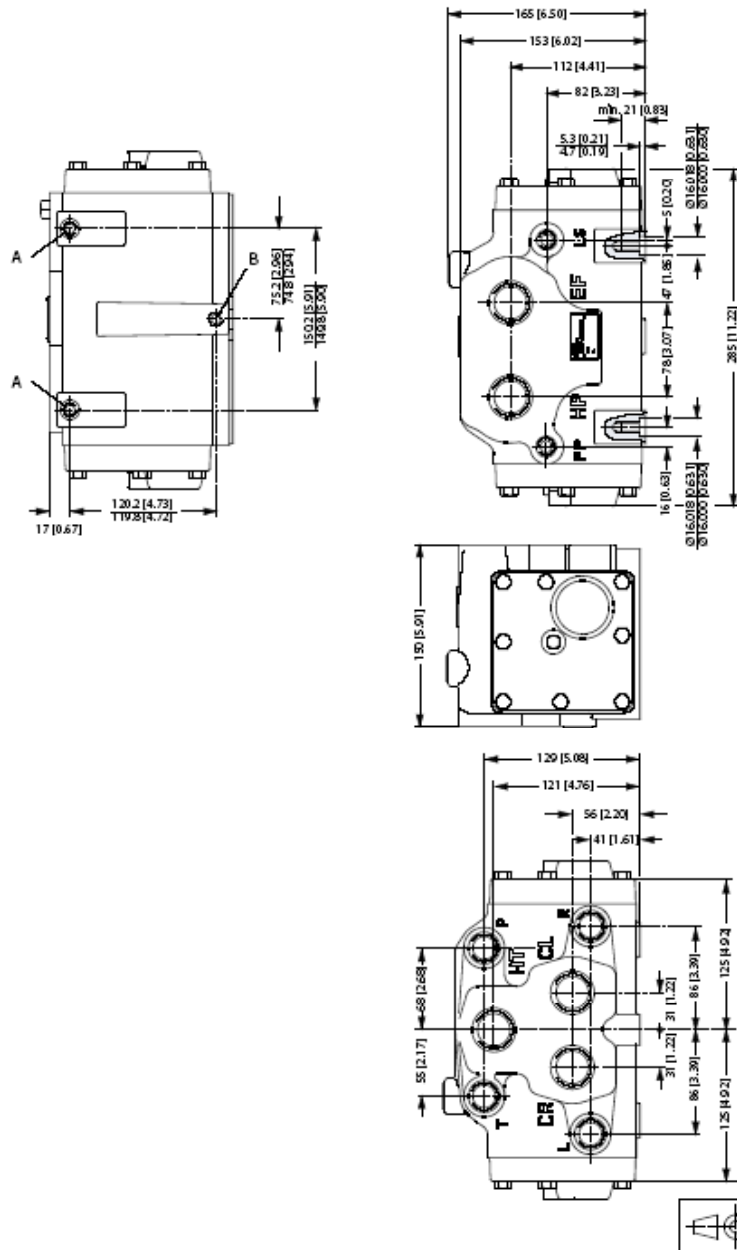

Flow Amplifiers OSQA, OSQB and OSQB/OLSQ

Dimensions OSQB

European version:
HP, EF:
1 ¼ in SAE flange
7/16-14 UNC
18 mm [0.71 in] deep (8)

HT, CL, CR:
1 in SAE flange
3/8 - 16 UNC
18 mm [0.71 in] deep (12)

P, T, L, R: G ½
PP, LS: G ¼

A: M10 x 1,5, 21 mm [0.83 in] deep
B: M10 x 1,5, 16 mm [0.63 in] deep

US version:
HP, EF:
1 ¼ in SAE flange
7/16 - 14 UNC
18 mm [0.71 in] deep (8)

HT, CL, CR:
1 in SAE flange
3/8 - 16 UNC
18 mm [0.71 in] deep (12)

P, T, L, R: ¾ - 16 UNF
PP, LS: 7/16 - 20 UNF

A:
7/16 - 14 UNC, 21 mm [0.83 in] deep
B:
7/16 - 14 UNC, 16 mm [0.63 in] deep

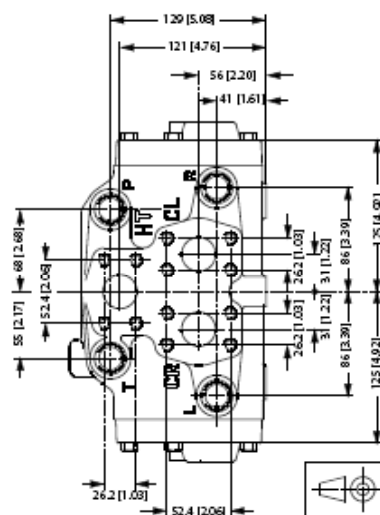
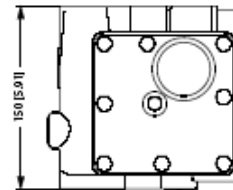
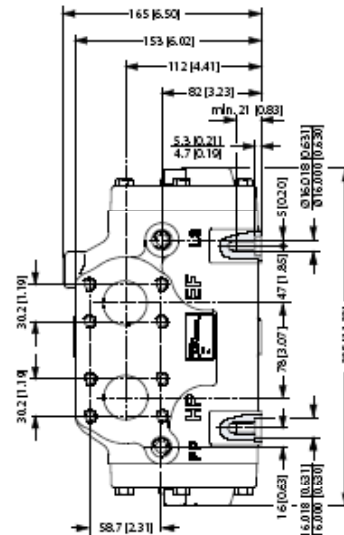
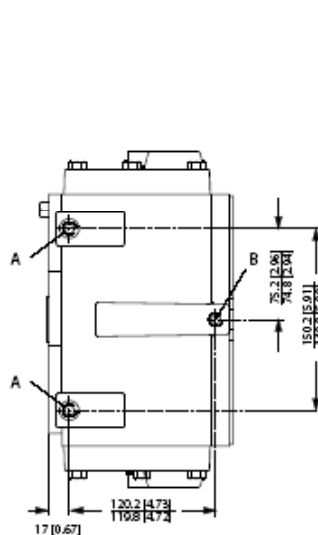

150F37.10

Flow Amplifiers OSQA, OSQB and OSQB/OLSQ

Dimensions OSQB with OLSQ

European version
HP, EF:
1 ¼ in SAE flange
7/16 - 14 UNC
18 mm [0.71 in] deep (8)

HT, CL, CR:
1 in SAE flange
5/8 - 16 UNC
18 mm [0.71 in] deep (12)

P_{OSQ}, P_{OLSQ}, T, L, R: G ½
PP, LS, P_{DR}: G ¼

A:
M10 x 1.5, 21 mm [0.83 in] deep
B:
M10 x 1.5, 16 mm [0.63 in] deep

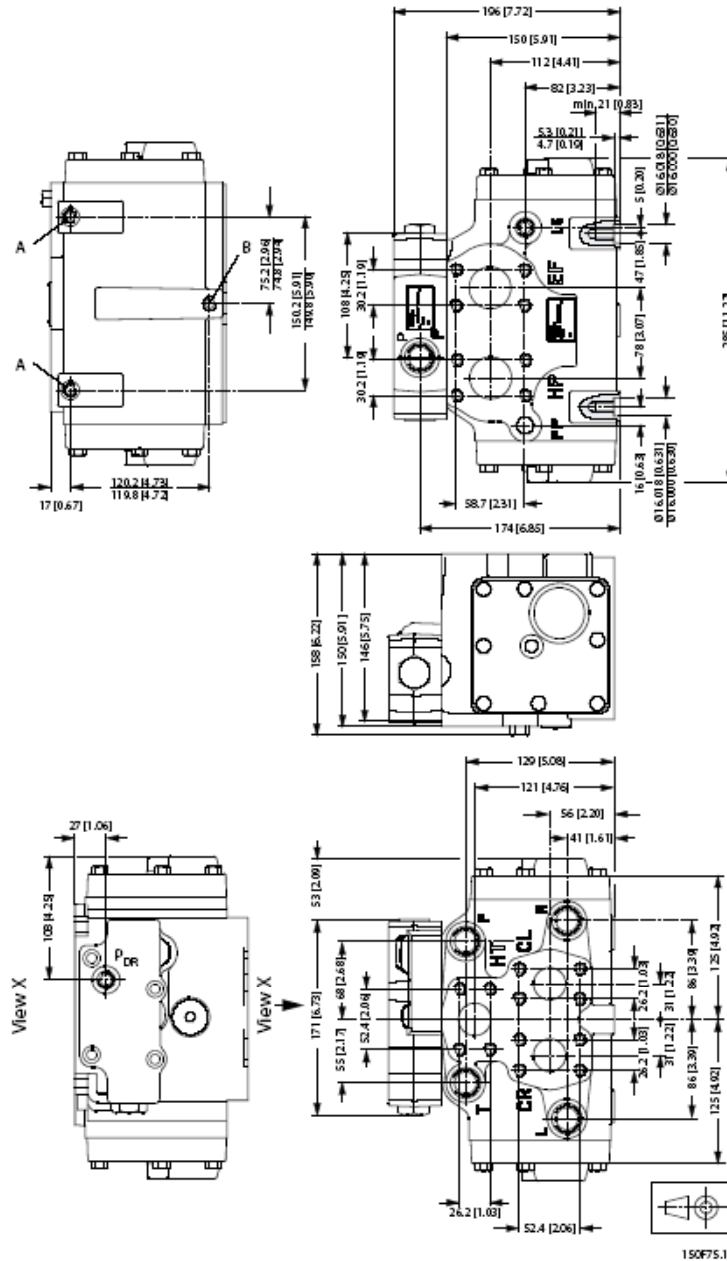

Products we offer:

- Bent Axis Motors
- Closed Circuit Axial Piston Pumps and Motors
- Displays
- Electrohydraulic Power Steering
- Electrohydraulics
- Hydraulic Power Steering
- Integrated Systems
- Joysticks and Control Handles
- Microcontrollers and Software
- Open Circuit Axial Piston Pumps
- Orbital Motors
- PLUS+1™ GUIDE
- Proportional Valves
- Sensors
- Steering
- Transit Mixer Drives