



MK MOTORS



MK7MKE35. COMPACT MOTOR.

Methodology :

This document is intended for manufacturers of machines that incorporate Poclairn Hydraulics products. It describes the technical characteristics of Poclairn Hydraulics products and specifies installation conditions that will ensure optimum operation.

This document includes important comments concerning safety. They are indicated in the following way:



Safety comment.

This document also includes essential operating instructions for the product and general information. These are indicated in the following way:



Essential instructions.



General information .



Information on the model number. Information on the model code.



Weight of component without oil.



Volume of oil.



Units.



Tightening torque.



Screws.



Information intended for Poclairn-Hydraulics personnel.

The views in this document are created using metric standards.

The dimensional data is given in mm and in inches (inches are between brackets and italic)



CONTENT

MODEL CODE **5** →

Model code

CHARACTERISTICS **7** →

Dimensions for standard 1-displacement motor	7	Characteristics
Dimensions for standard 2-displacement motor	7	
Dimensions of symmetrical 2-displacement valving cover standard motor	8	
Rotating retaining screws	8	
Load curves	9	
Efficiency	9	
Chassis mounting	10	
Hydraulic connections	11	
Brakes	12	

OPTIONS **13** →

Options

MODEL CODE

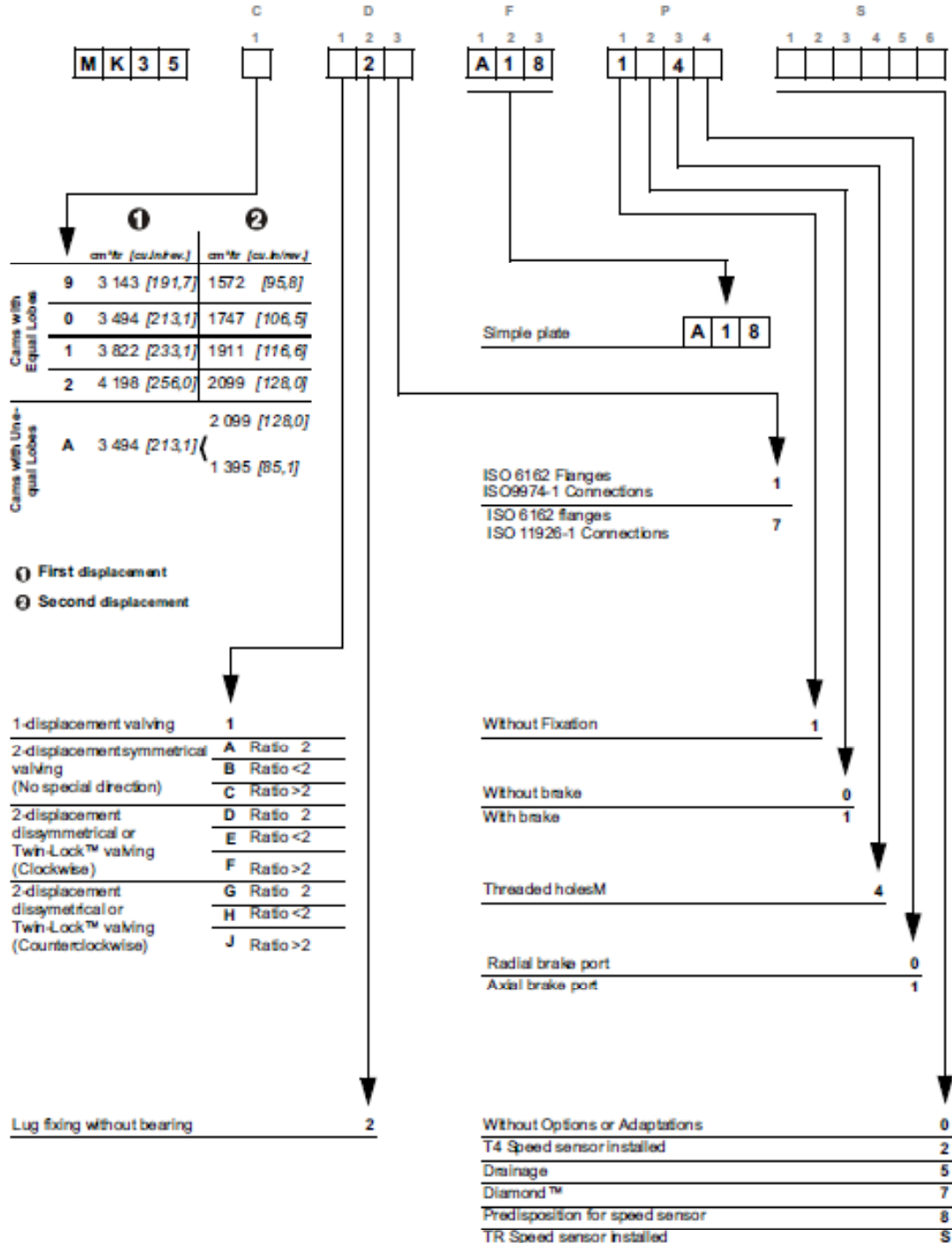

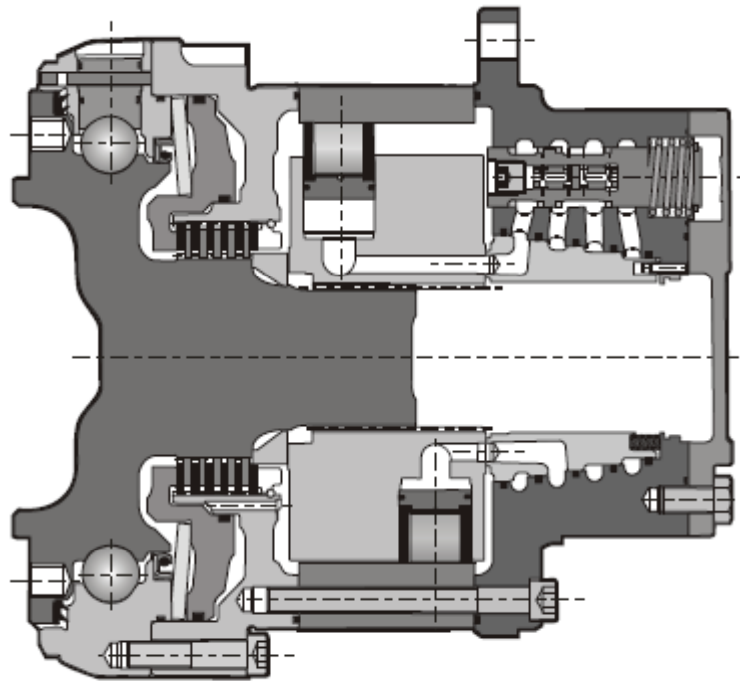

Motor Inertia 0.6 kg.m²

	Displacement		Theoretical torque		Max. power preferred	Max. power non-preferred	Max. speed		Max. pressure	
	①	②	①				①	②		
	cm ³ /tr [cu.in/rev.]	cm ³ /tr [cu.in/rev.]	at 100 bar Nm	at 1000 PSI [lb.ft]			tr/min[RPM]	tr/min[RPM]		bar [PSI]
Cams with Equal Lobes	9	3 143 [191,7]	1572 [95,8]	4 997 [2 541]	110 [148]	73 [98]	55 [74]	50	50	450 [6 530]
	0	3 494 [213,1]	1747 [106,5]	5 555 [2 825]						
	1	3 822 [233,1]	1911 [116,6]	6 077 [3 090]						
	2	4 198 [256,0]	2099 [128,0]	6 675 [3 394]						
Cams with Unequal Lobes	A	3 494 [213,1]	2 099 [128,0]	5 555 [2 825]	110 [148]	73 [98]	55 [74]	50	50	450 [6 530]
			1 395 [85,1]							

- ① First displacement
- ② Second displacement



CHARACTERISTICS

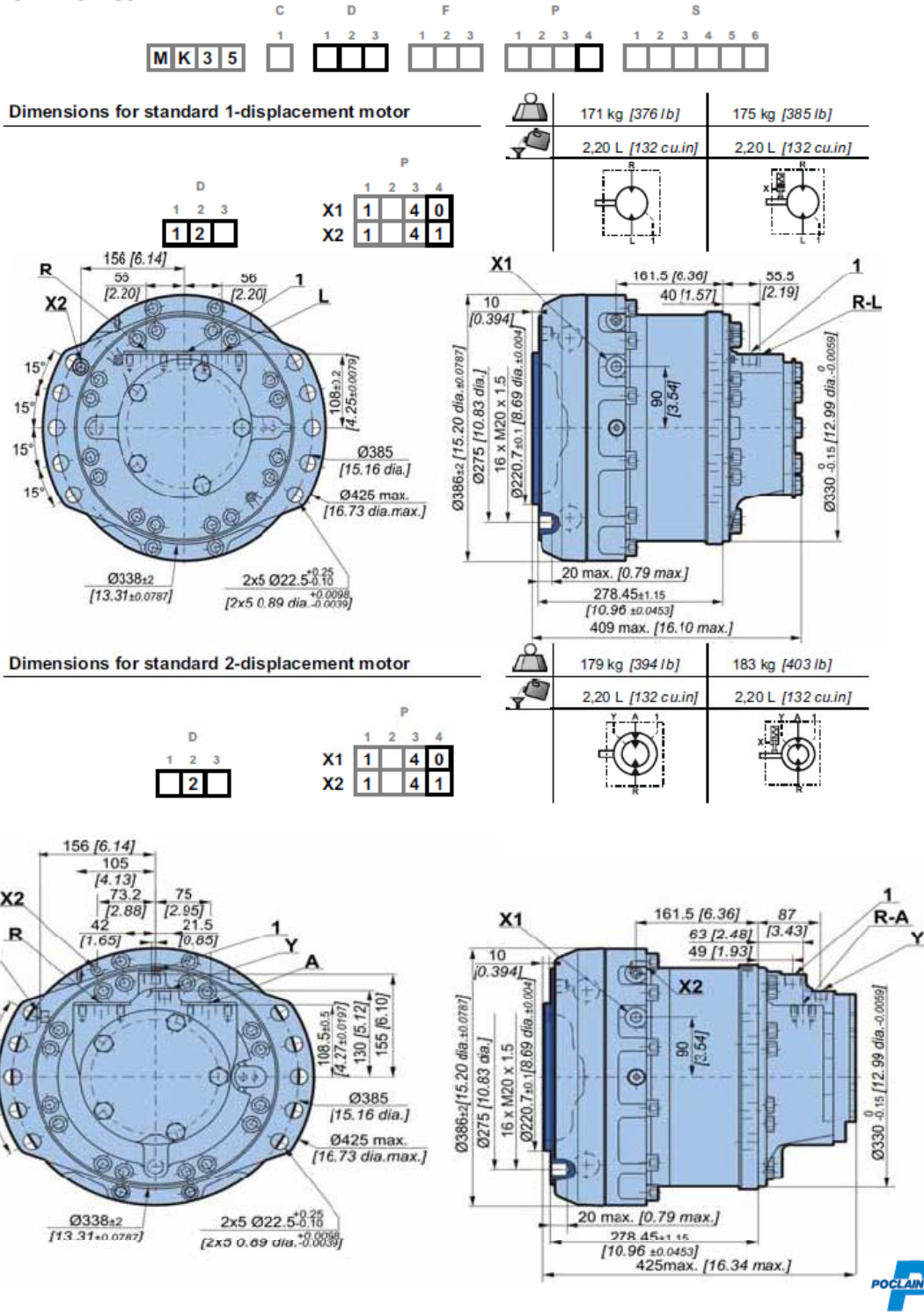

Dimensions of symmetrical 2-displacement valving cover standard motor

For a small displacement, there is no preferred orientation for this motor.

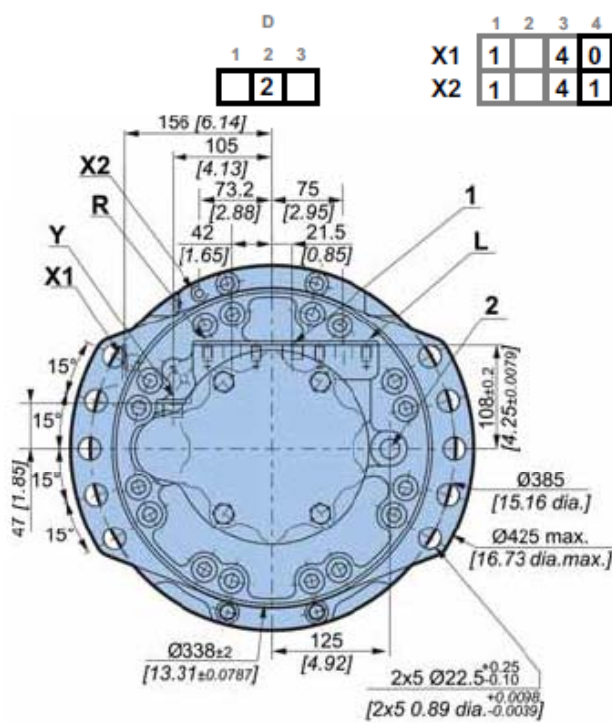

	181 kg [398 lb]	185 kg [407 lb]
	2,20 L [132 cu.in]	2,20 L [132 cu.in]

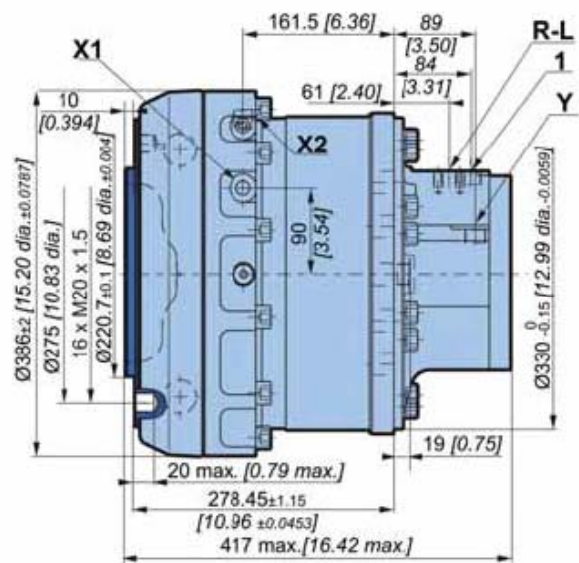

Rotating retaining screws

	Classe	N.m		[lb.ft]
16 x M20 x 1.5	10,9	690		[509]

(*) The tightening torques are given for the indicated loads.

Load curves

Permissible radial loads

Test conditions :

Static : 0 tr/min [0 RPM] 0 bar [0 PSI]

Dynamic : 0 tr/min [0 RPM], code 0 displacement, without axial load at max. torque

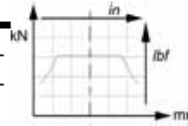

Service life of bearings

Test conditions :

L : Millions B10 revolutions at 150 bars (average pressure), with 25 cSt fluid, code 0 displacement, without axial load.



The service life of the components is influenced by the pressure. You must check that the combination of forces applied (Axial load / Radial load) is compatible with the permissible loads for the components, and that the resulting service lives of these components complies with the application's specifications. For an accurate calculation, consult your Poclain Hydraulics application engineer.

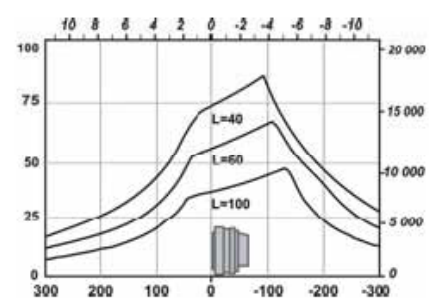
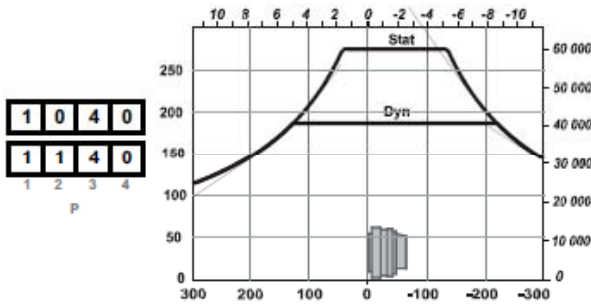
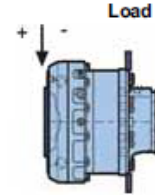

Efficiency

Overall efficiency

Average values given for guidance for code 0 displacement after 100 hours of operation with HV46 hydraulic fluid at 50°C [122°F].

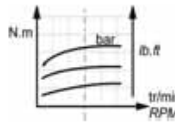
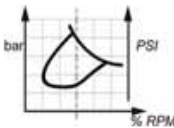

Actual output torque

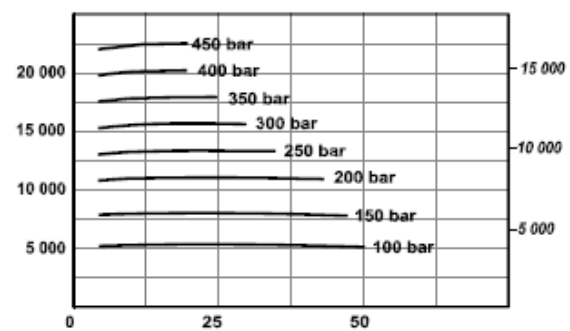
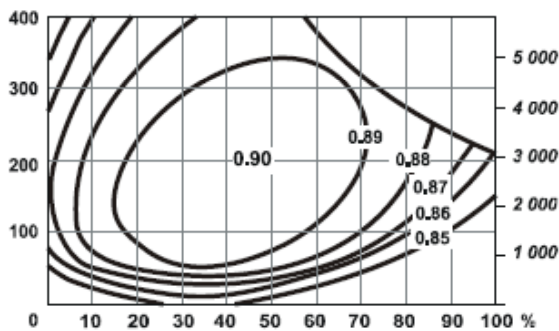



The starting torque is taken to be approximately 85% of the first value for available pressure. For a precise calculation, consult your Poclain Hydraulics application engineer.

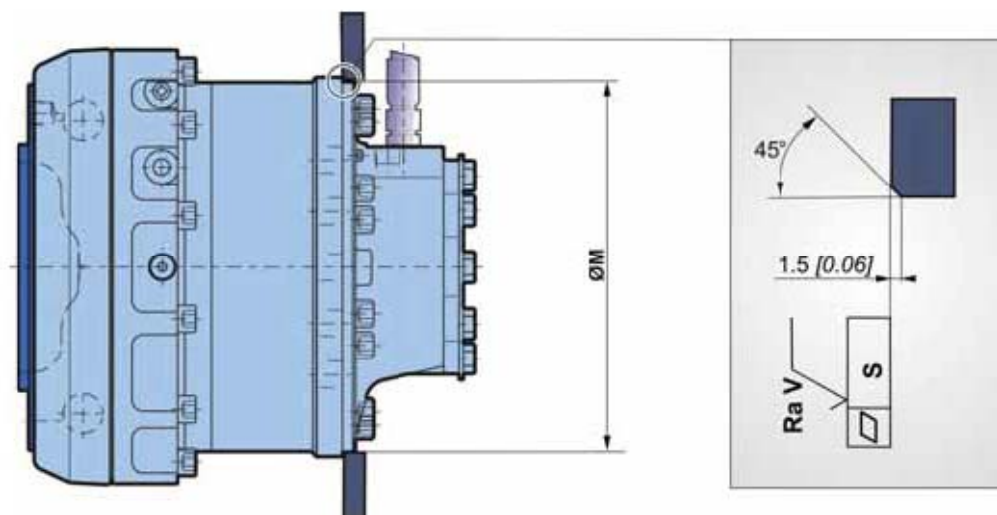

Chassis mounting



Take care over the immediate environment of the connections.

ØM (1) mm [in]	S mm [in]	Ra V µm [µin]		Class of screw	 N.m [lb.ft]
330 [12,99]	0,2 [0,01]	12,5 [0,49]	2 x 5 x M20 x 2.5	8,8	410 [302]

(1) + 0.3 [+0.012]
+ 0.2 [+0.008]

Hydraulic connections
connections

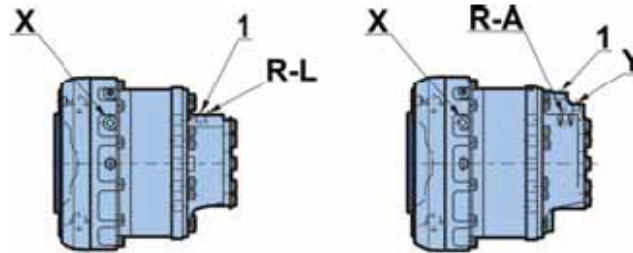

	Old standards	Standards	Power supply R, L, A	2 nd displacement control Y	Drainage 1, 2	Control of brake X
1	ISO 6 162 DIN 3 852	ISO 6162 ISO 9 974-1	DN19 PN400	M22 x 1.5* M18 x 1.5**	M22 x 1.5	M16 x 1.5
7	DIN 6162 SAEJ514	DIM 6162 ISO 11 926-1	DN19 PN400	7/8" 14 UNF* 3/4" 16 UNF**	7/8" 14 UNF	3/4" 16 UNF

* If D1 = A, B or C (Symmetrical motor)

** If D1 = D, E, F, G, H or J (Disymmetrical motor)

Brakes

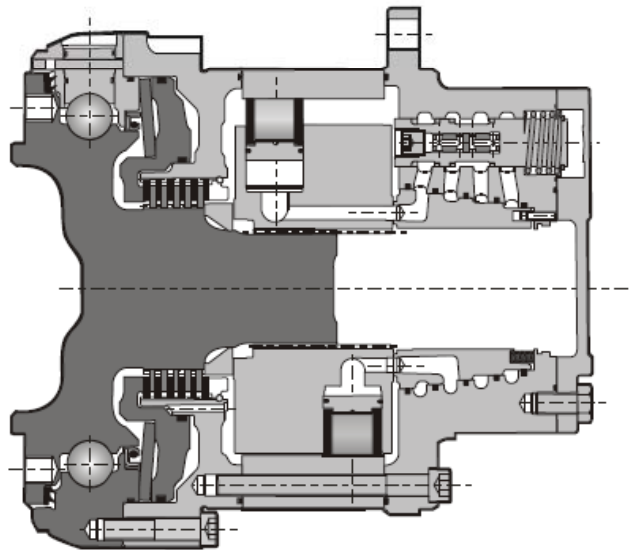
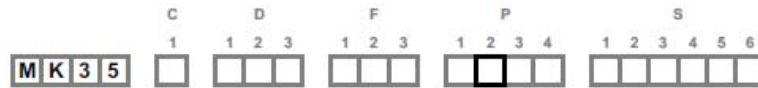

Brake principle

This is a multidisc brake which is activated by a lack of pressure. The spring exerts a force on the piston, which presses on the fixed and mobile discs, and immobilizes the shaft. The braking torque decreases in linear proportion to the brake release pressure.

Parking brake torque with 0 bars in the housing (new brake)	33 000 N.m	[24 340 lb.ft]
Emergency dynamic braking torque with 0 bars in the housing (gives a maximum of 10 emergency braking operations)	21 450 N.m	[15 820 lb.ft]
Residual parking torque at 0 bars in the housing *	24 750 N.m	[18 250 lb.ft]
Minimum brake release pressure	16 bar	[232 PSI]
Maximum brake release pressure	30 bar	[435 PSI]
Capacity	320 cm ³	[19,5 cu.in]
Brake release capacity	65 cm ³	[4,0 cu.in]

* After being used as emergency brake



The brake is integral to the bearing; refer to the model code (tab opposite).

OPTIONS

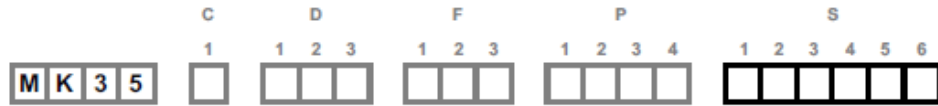

You can accumulate more than one optional part. Consult your Poclair Hydraulics sales engineer.

2 - S - 8 - Installed speed sensor or predisposition

Designation	C
T4 Speed sensor installed	2
TR Speed sensor installed (direction of rotation)	S
Predisposition for speed sensor	8

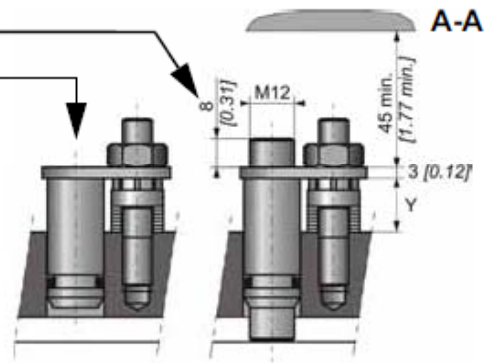
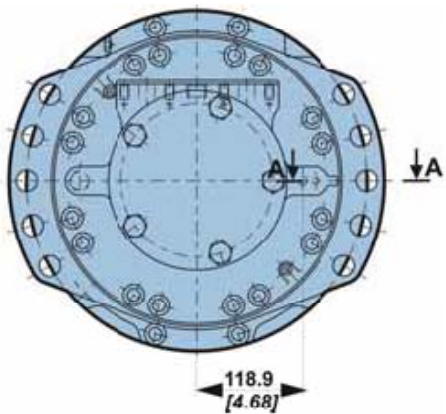

Max. length Y= 17.1
Standard number of pulses per revolution= 60



Look at the "Mobile Electronic" N° A01889D technical catalogue for the sensor specifications and its connection.



To install the sensor, see the "Installation guide" brochure No. 801478197L.

5 - Drainage

Additional drain in the cover.

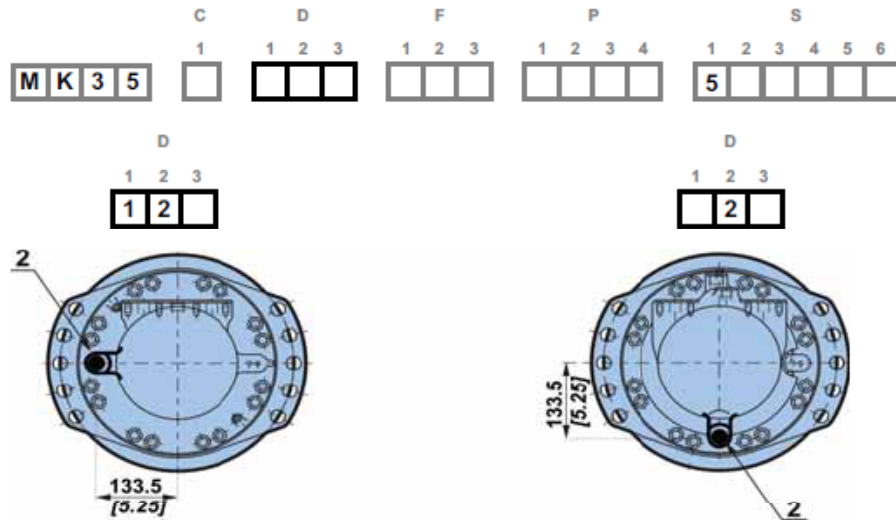

7 - Diamond™

Special treatment of the motor core which considerably increases its strength, making the motor much more tolerant to temporary instances of the operating conditions being exceeded.