



MK MOTORS



MK/MKE18. COMPACT MOTOR.

Methodology :

This document is intended for manufacturers of machines that incorporate Poclain Hydraulics products. It describes the technical characteristics of Poclain Hydraulics products and specifies installation conditions that will ensure optimum operation.

This document includes important comments concerning safety. They are indicated in the following way:



Safety comment.

This document also includes essential operating instructions for the product and general information. These are indicated in the following way:



Essential instructions.



General information .



Information on the model code.



Weight of component without oil.



Volume of oil.



Units.



Tightening torque.



Screws.



Information intended for Poclain-Hydraulics personnel.

The views in this document are created using metric standards.

The dimensional data is given in mm and in inches (inches are between brackets and italic)



CONTENT

MODEL CODE	5	Model code
CHARACTERISTICS	7	
Dimensions for standard 1-displacement motor	7	
Dimensions for standard 2-displacement motor	7	
Dimensions of symmetrical 2-displacement valving cover standard motor	8	
Rotating fastening screw	8	
Load curves	9	
Efficiency	10	
Chassis mounting	11	
Hydraulic connections	12	
Rear brake	13	
		Options
OPTIONS	15	

MODEL CODE

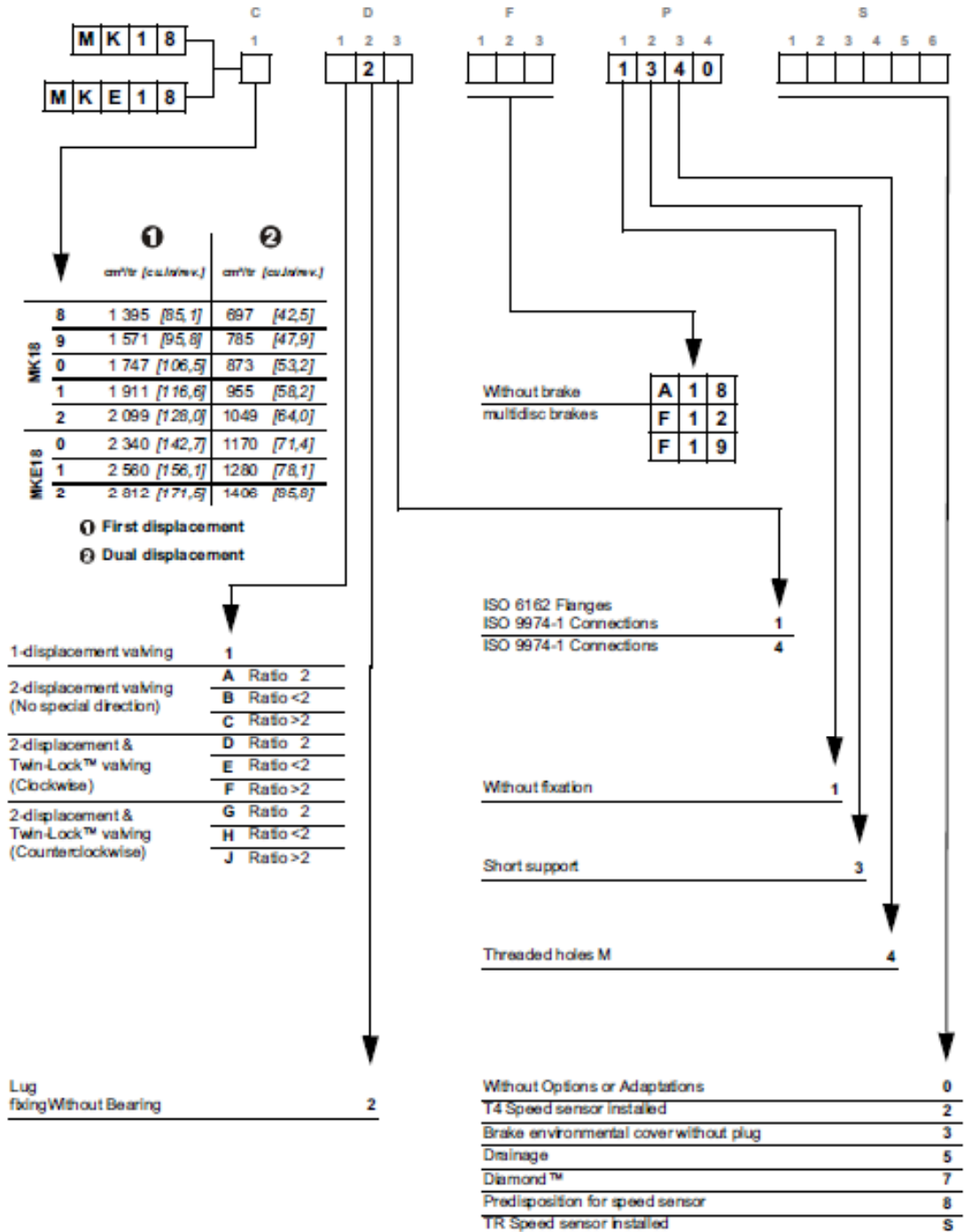

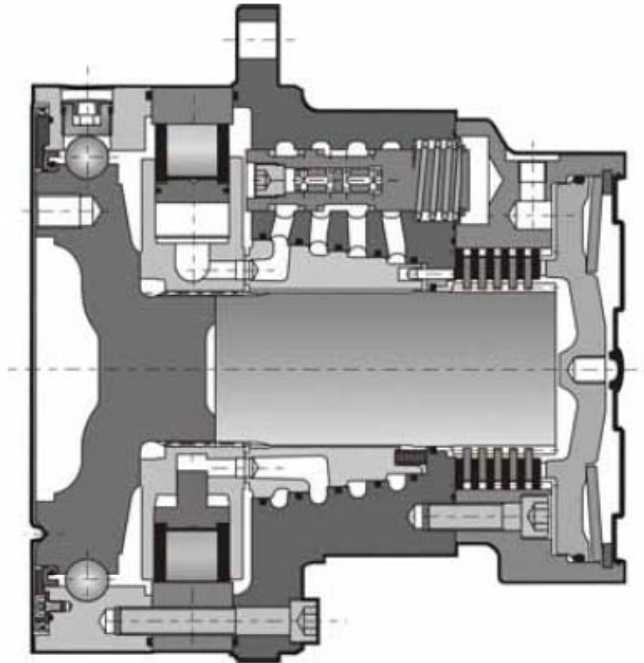

Motor Inertia 0.2 kg.m²

	①		②		Theoretical torque		Max. power			Max. speed		Max. pressure bar [PSI]	
	①		②		①		②		①		②		
	cm ³ /tr [cu.in/rev.]	cm ³ /tr [cu.in/rev.]	Nm	[lb.ft]	kW [HP]	preferred kW [HP]	non-preferred kW [HP]	tr/min	[RPM]				
MIK18	8	1 395 [85,1]	697 [42,5]	2 218 [1 128]					155	160			
	9	1 571 [95,8]	785 [47,9]	2 498 [1 270]				140	155				
	0	1 747 [106,5]	873 [53,2]	2 778 [1 413]	70 [94]	47 [63]	35 [47]	125	150	450 [6 530]			
	1	1 911 [116,6]	955 [58,2]	3 038 [1 545]				115	135				
	2	2 099 [128,0]	1049 [64,0]	3 337 [1 697]				100	125				
MIKE18	0	2 340 [142,7]	1170 [71,4]	3 721 [1 892]				90	110				
	1	2 560 [156,1]	1280 [78,1]	4 070 [2 070]	70 [94]	47 [63]	35 [47]	85	100	400 [5 800]			
	2	2 812 [171,5]	1406 [85,8]	4 471 [2 274]				75	90				

- ① First displacement
② Second displacement

CHARACTERISTICS

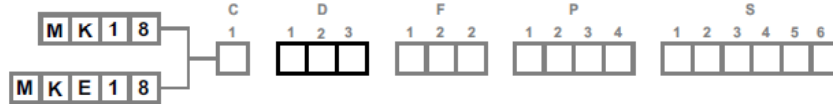

Dimensions for standard 1-displacement motor

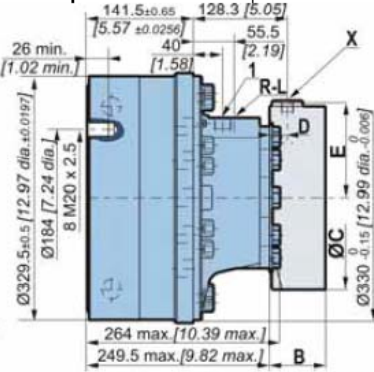
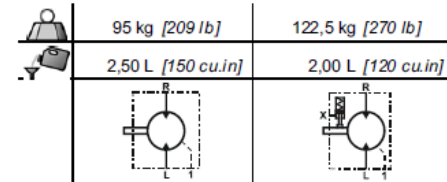
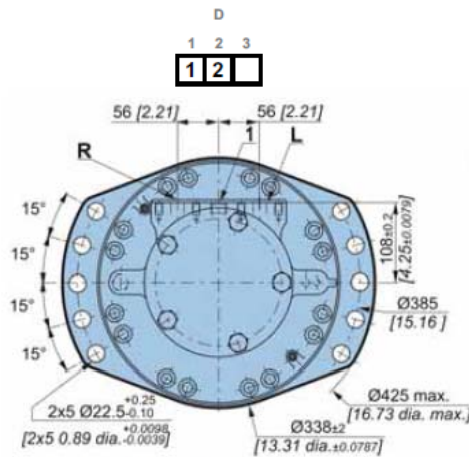

Dimensions for standard 2-displacement motor

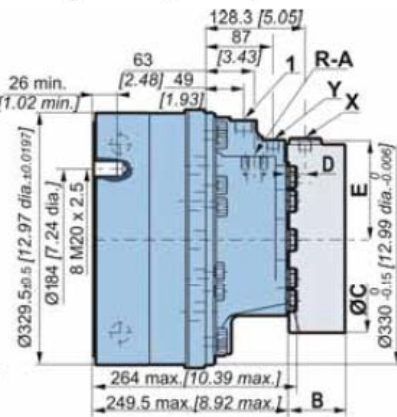
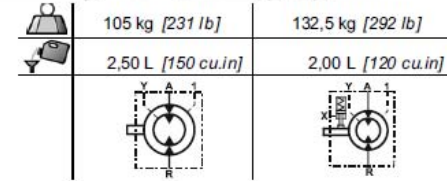
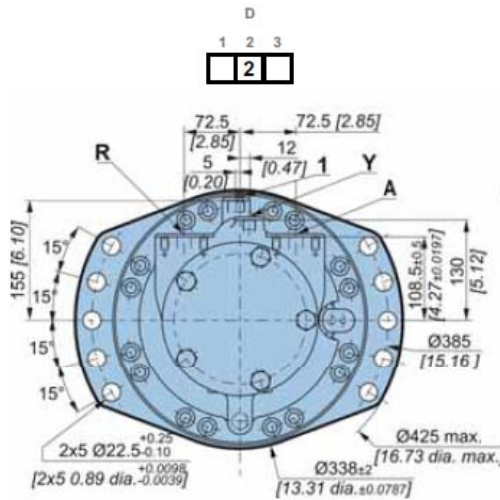

C	F12	F19
B	76,7 [3,02]	98,5 [3,88]
ØC	247 [9,72]	250 [9,84]
D	25 [0,98]	45 [1,77]
E	128,5 [5,06]	121,5 [4,78]

Also see 'Brakes' section.



Dimensions of symmetrical 2-displacement valving cover standard motor

For a small displacement, there is no preferred orientation for this motor.

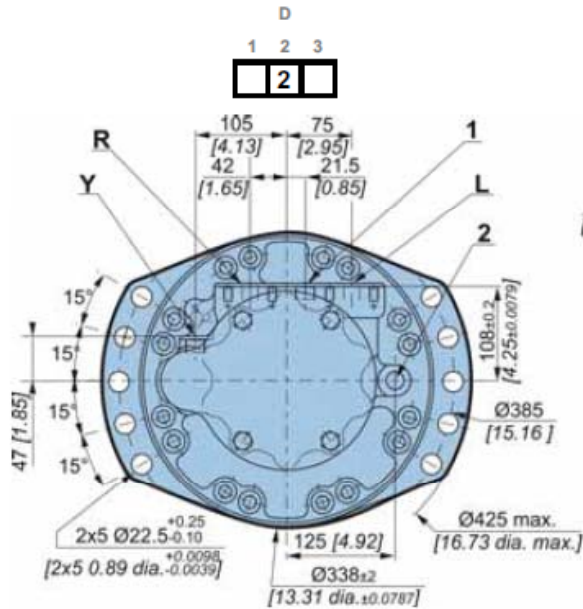

	107 kg [235 lb]	135 kg [296 lb]
	2,50 L [150 cu.in]	2,00 L [120 cu.in]

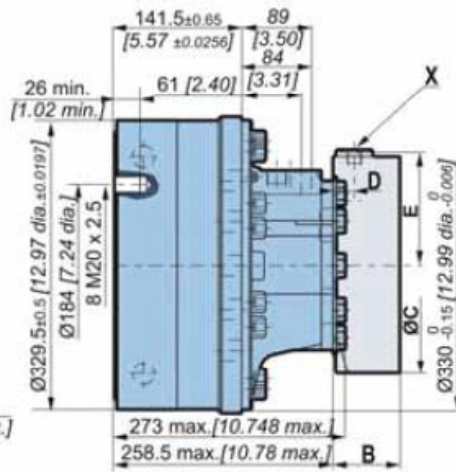

	F12	F19
C		
B	76,7 [3,02]	98,5 [3,88]
ØC	247 [9,72]	250 [9,84]
D	25 [0,98]	45 [1,77]
E	128,5 [5,06]	121,5 [4,78]

Also see 'Brakes' section.

Rotating fastening screw

	Classe	N.m	[lb.ft]
8 x M20 x 2,5	10,9	580	[428]

(*) The tightening torques are given for the indicated loads.

Load curves

Permissible radial loads

Test conditions :

Static : 0 tr/min [0 RPM] 0 bar [0 PSI]

Dynamic : 0 tr/min [0 RPM], code 0 displacement, without axial load at max. torque

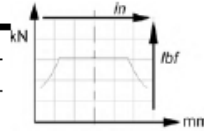

Service life of bearings

Test conditions :

L : Millions B10 revolutions at 150 bars (average pressure), with 25 cSt fluid, code 0 displacement, without axial load.

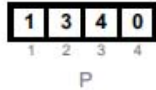
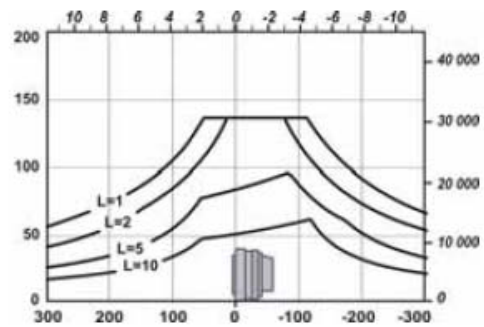
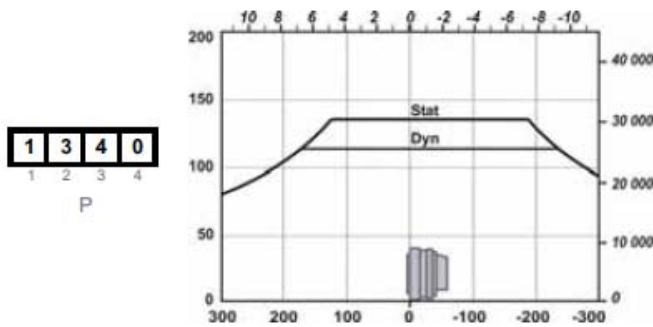

The service life of the components is influenced by the pressure. You must check that the combination of forces applied (Axial load / Radial load) is compatible with the permissible loads for the components, and that the resulting service lives of these components complies with the application's specifications. For an accurate calculation, consult your Poclain Hydraulics application engineer.

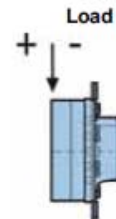

Efficiency

Overall efficiency

Average values given for guidance for code 0 displacement after 100 hours of operation with HV46 hydraulic fluid at 50°C [122°F].

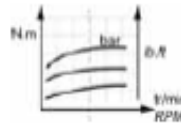
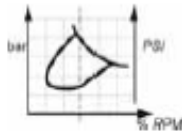

Actual output torque

MK18

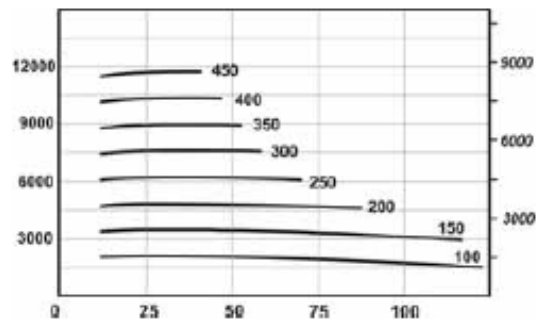
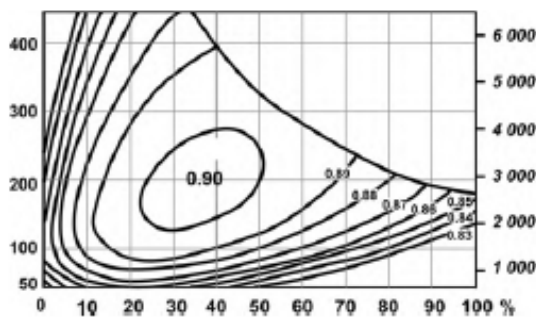

MKE18

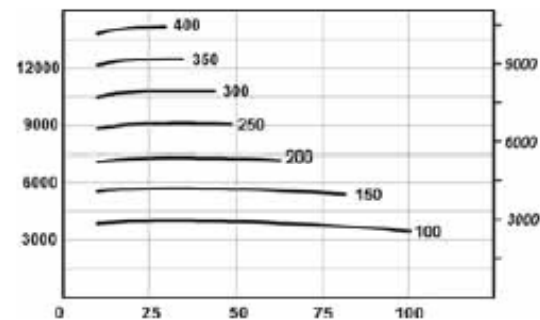
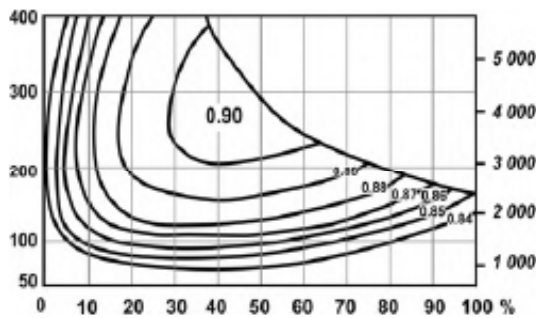

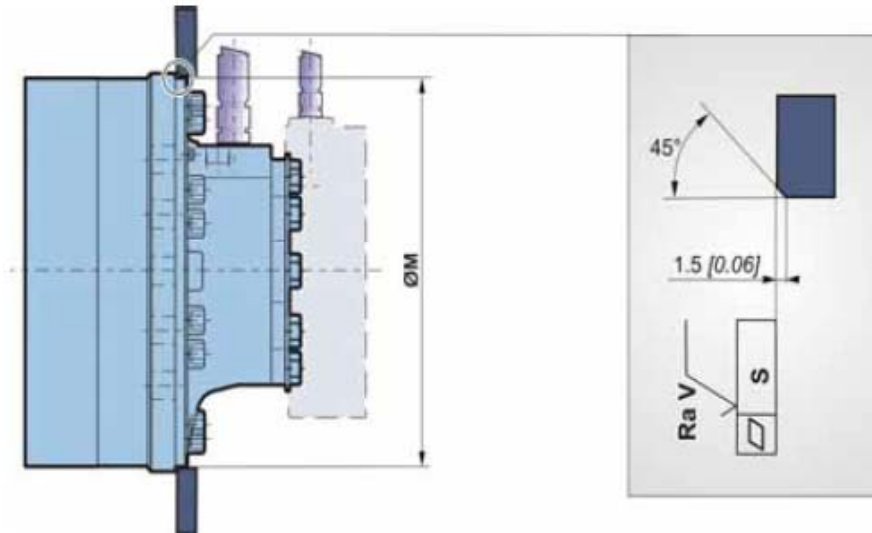

The starting torque is taken to be approximately 85% of the first value for a available pressure. For a precise calculation, consult your Poclair Hydraulics application engineer.

Chassis mounting



Take care over the immediate environment of the connections.

$\varnothing M$ (1) mm [in]	S mm [in]	Ra V μm [μin]		Class of screw	 N.m [lb.ft]
330 [12,99]	0,2 [0,01]	12,5 [0,49]	2 x 5 x M20 x 2.5	8,8	410 [302]

(1) + 0.3 [+0.012]
+ 0.2 [+0.008]

Hydraulic connections
connections

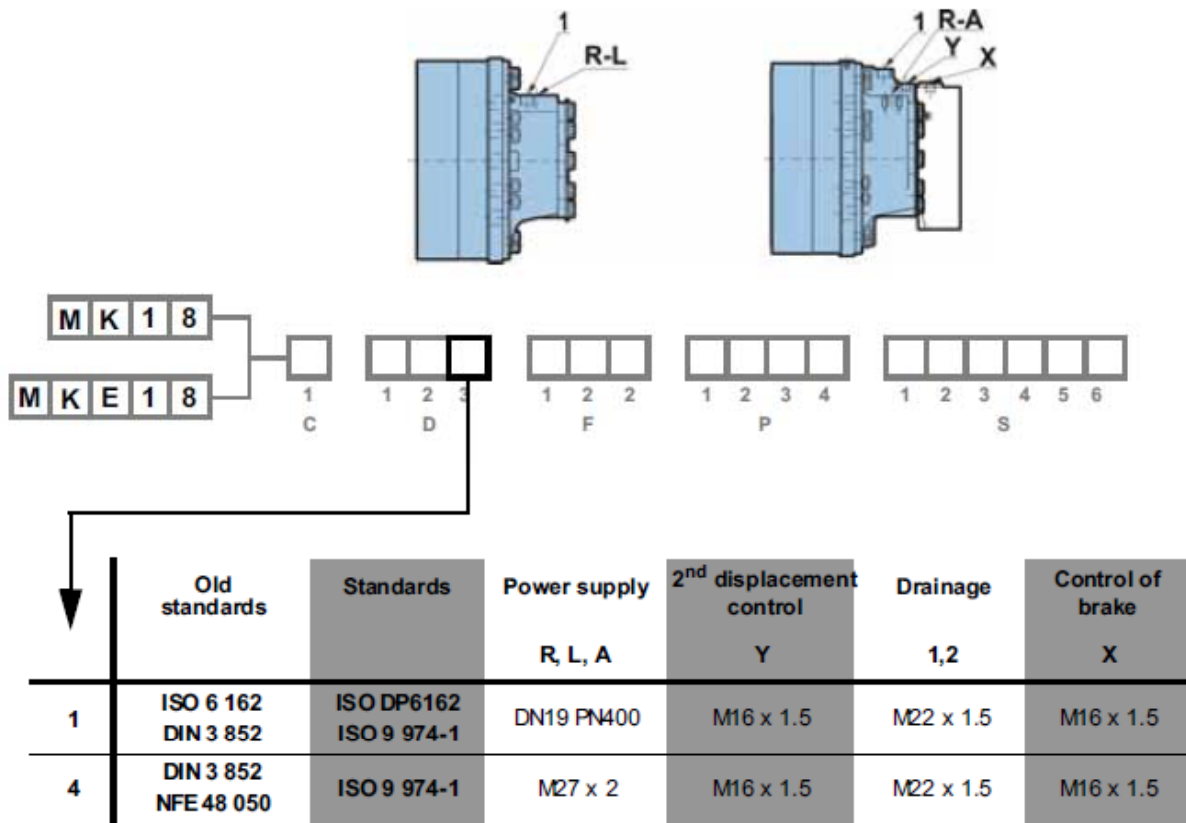

To find the connections' tightening torques, see the brochure "Installation guide" N° 801478197L.

Rear brake

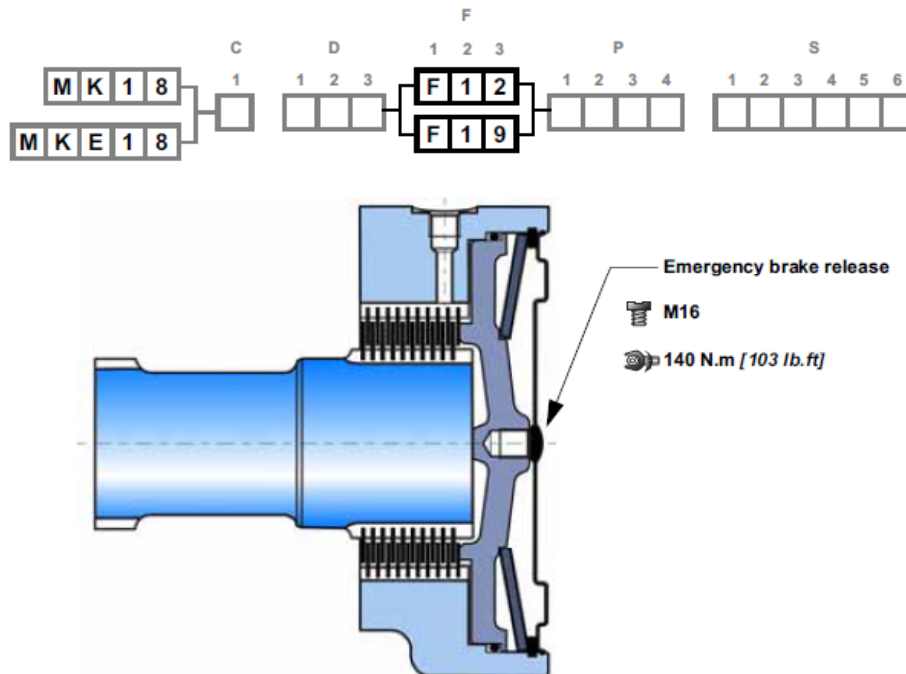

Brake principle

This is a multidisc brake which is activated by a lack of pressure. The spring exerts a force on the piston, which presses on the fixed and mobile discs, and immobilizes the shaft. The braking torque decreases in linear proportion to the brake release pressure.

C	F12	F19
Parking brake torque with 0 bars in the housing (new brake)	11 840 N.m [8 730 lb.ft]	18 600 N.m [13 720 lb.ft]
Emergency dynamic braking torque with 0 bars in the housing (gives a maximum of 10 emergency braking operations)	7 695 N.m [5 680 lb.ft]	12 800 N.m [9 440 lb.ft]
Residual parking torque at 0 bars in the housing*	8 880 N.m [6 550 lb.ft]	13 940 N.m [10 280 lb.ft]
Minimum brake release pressure	12 bar [174,0 PSI]	12 bar [174,0 PSI]
Maximum brake release pressure	30 bar [435,1 PSI]	30 bar [435,1 PSI]
Capacity	170 cm ³ [10,4 cu.in]	180 cm ³ [11,0 cu.in]
Brake release capacity	40 cm ³ [2,4 cu.in]	70 cm ³ [4,3 cu.in]

* After being used as emergency brake



Do not run in multidisc brakes.



A functional check of the parking brake must be carried out each time it is used as an auxiliary brake (or emergency brake). For all vehicles capable of speeds over 25 km/hour, please contact your Poclairn Hydraulics application engineer.



OPTIONS

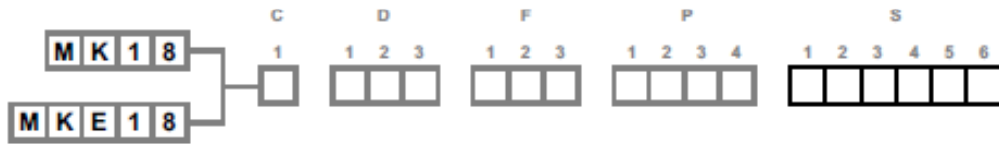

You can accumulate more than one optional part. Consult your Poclain Hydraulics sales engineer.

2 - S - 8 - Installed speed sensor or predisposition

Designation	C
T4 Speed sensor installed	2
TR Speed sensor installed	S
Predisposition for speed sensor	8

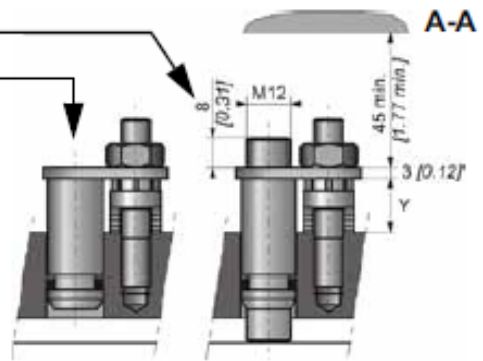
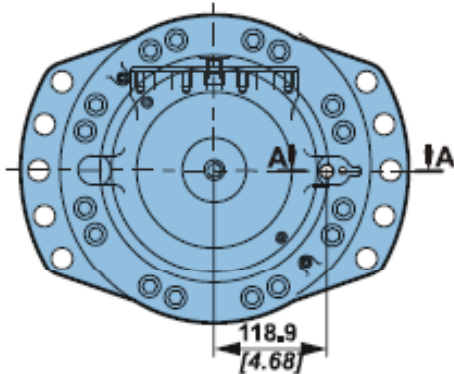

Max. length Y= 18.1
Standard number of pulses per revolution= 60



Look at the "Mobile Electronic" N° A01889D technical catalogue for the sensor specifications and its connection.



To install the sensor, see the "Installation guide" brochure No. 801478197L.

7 - Diamond™

Special treatment of the motor core which considerably increases its strength, making the motor much more tolerant to temporary instances of the operating conditions being exceeded.

3 - Brake environmental cover without plug

No plug or hole in the cover.
(see figure opposite)

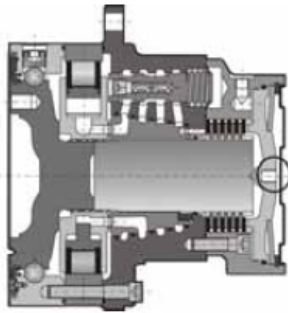

5 - Drainage

Additional drain in the cover.

