

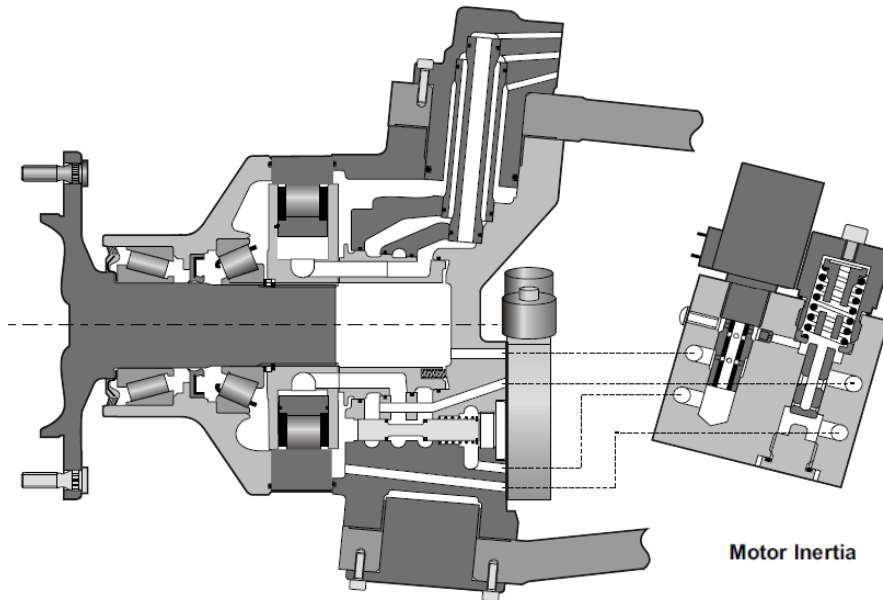

MG MOTORS



MG11-MGE11. STEERABLE WHEEL MOTOR.



Motor Inertia : 0.05 kg.m²

	①	②	Theoretical torque		①	Max.power		Max. speed		Max. pressure			
			cm ³ /tr [cu.in/rev.]	cm ³ /tr [cu.in/rev.]		at 100 bar		kW [HP]	② preferred kW [HP]		② non-preferred kW [HP]	①	
						Nm	[lb.ft]					tr/min	[RPM]
Cams with equal lobes MG11	7	730 [44,5]	365 [22,3]	1 161	[590]	50 [67]	33 [44]	25 [34]	200		450 [6 530]		
	8	837 [51,0]	419 [25,5]	1 331	[677]				195				
	9	943 [57,5]	472 [28,8]	1 499	[762]				190				
	0	1 048 [63,9]	524 [32,0]	1 666	[847]				185				
	1	1 147 [70,0]	574 [35,0]	1 824	[927]				180				
	2	1 259 [76,8]	630 [38,4]	2 002	[1 018]				170 175				
	9	1 263 [77,0]	632 [38,5]	2 008	[1 021]				170 190				
Cams with equal lobes MGE11	0	1 404 [85,6]	702 [42,8]	2 232	[1 135]	50 [67]	33 [44]	25 [34]	155 185		400 [5 800]		
	1	1 536 [93,7]	768 [46,8]	2 442	[1 242]				140 180				
	2	1 687 [102,9]	844 [51,4]	2 682	[1 364]				130 165				
Cams with unequal lobes MG11	A	1 048 [63,9]	629 [38,4] 419 [25,6]	1 666	[847]	50 [67]	33 [44]	25 [34]	170		450 [6 530]		
	A	1 404 [85,6]	843 [51,4] 561 [34,2]	2 232	[1 135]				120			400 [5 800]	

- ① First displacement
② Second displacement

CONTENT

MODEL CODE	5	Model code
CHARACTERISTICS	6	Characteristics
Standard (1910) single displacement motor with built-in exchange	6	
Standard (1910) 2 displacement motor with built-in exchange	7	
Exchange	7	
Load curves	8	
Efficiency	9	
Wheel rim mountings	10	
Chassis mounting	10	
Steering attachment	11	
Steering angle	11	
Hydraulic connections	12	
OPTIONS	13	Options

Methodology :

This document is intended for manufacturers of machines that incorporate Poclairn Hydraulics products. It describes the technical characteristics of Poclairn Hydraulics products and specifies installation conditions that will ensure optimum operation.

This document includes important comments concerning safety. They are indicated in the following way:



Safety comment.

This document also includes essential operating instructions for the product and general information. These are indicated in the following way:



Essential instructions.



General information .



Information on the model code.



Weight of component without oil.



Volume of oil.



Units.



Tightening torque.



Screws.



Information intended for Poclairn-Hydraulics personnel.

The views in this document are created using metric standards.

The dimensional data is given in mm and in inches (inches are between brackets and italic)



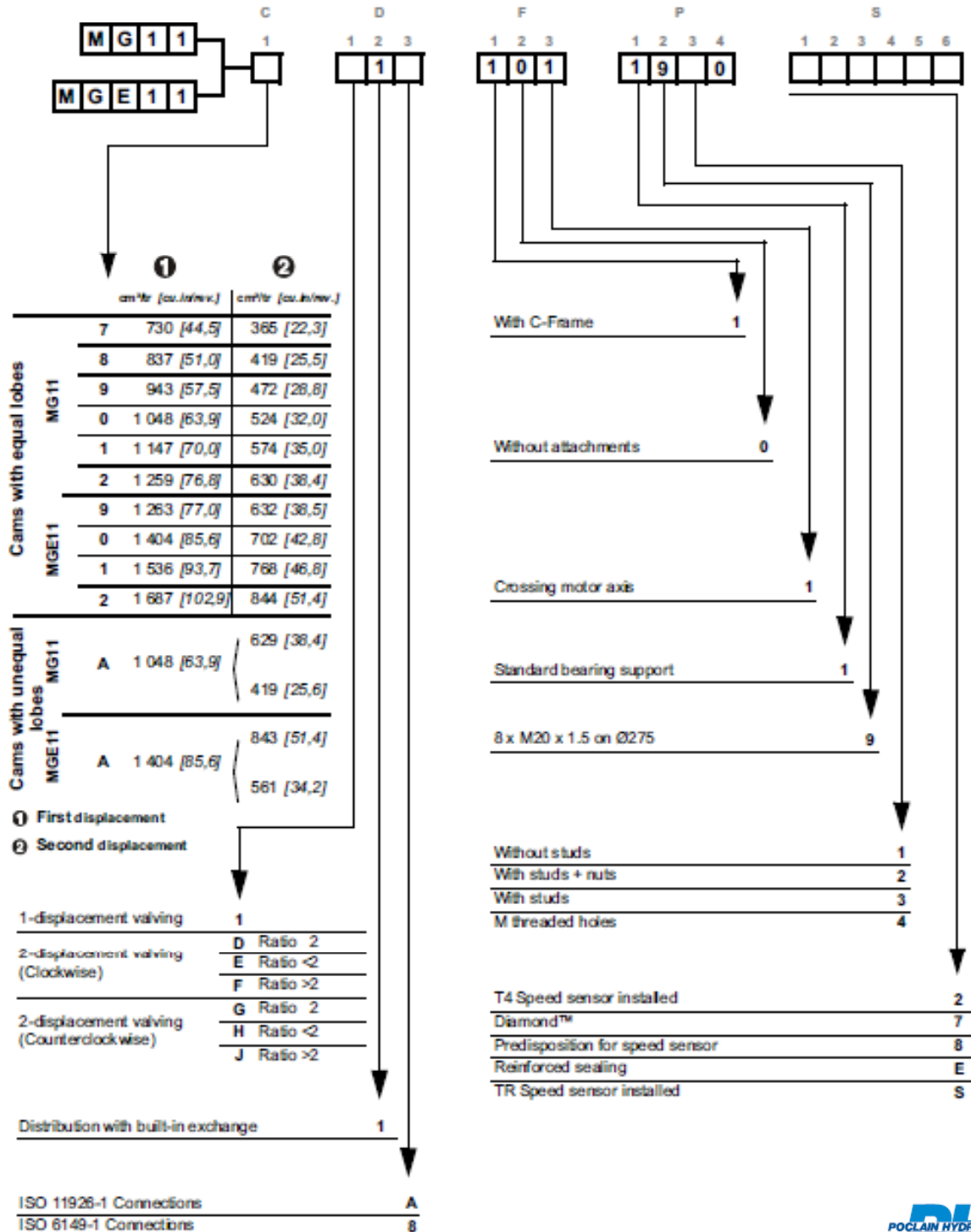

MODEL CODE



CHARACTERISTICS

Standard (1910) single displacement motor with built-in exchange

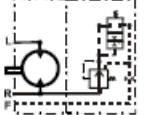
	210 kg [462 lb]
	1,00 L [60 cu.in]
	

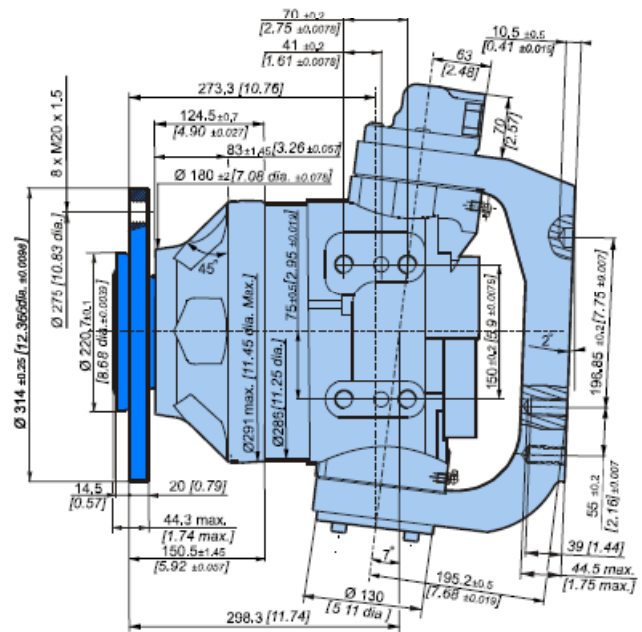
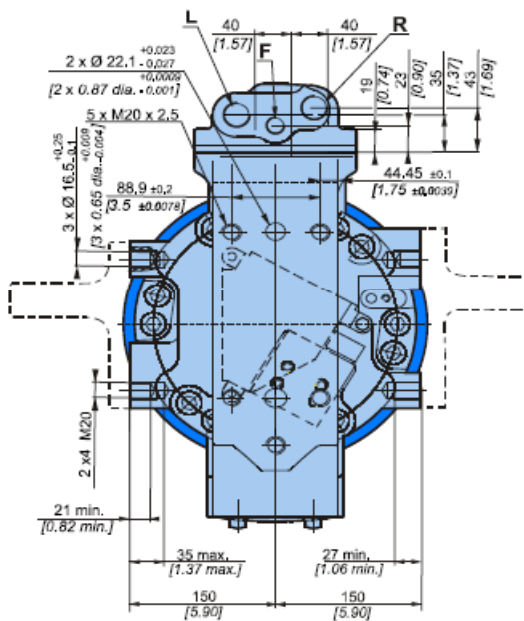

Standard (1910) 2 displacement motor with built-in exchange

	210 kg [462 lb]
	1,00 L [60 cu.in]

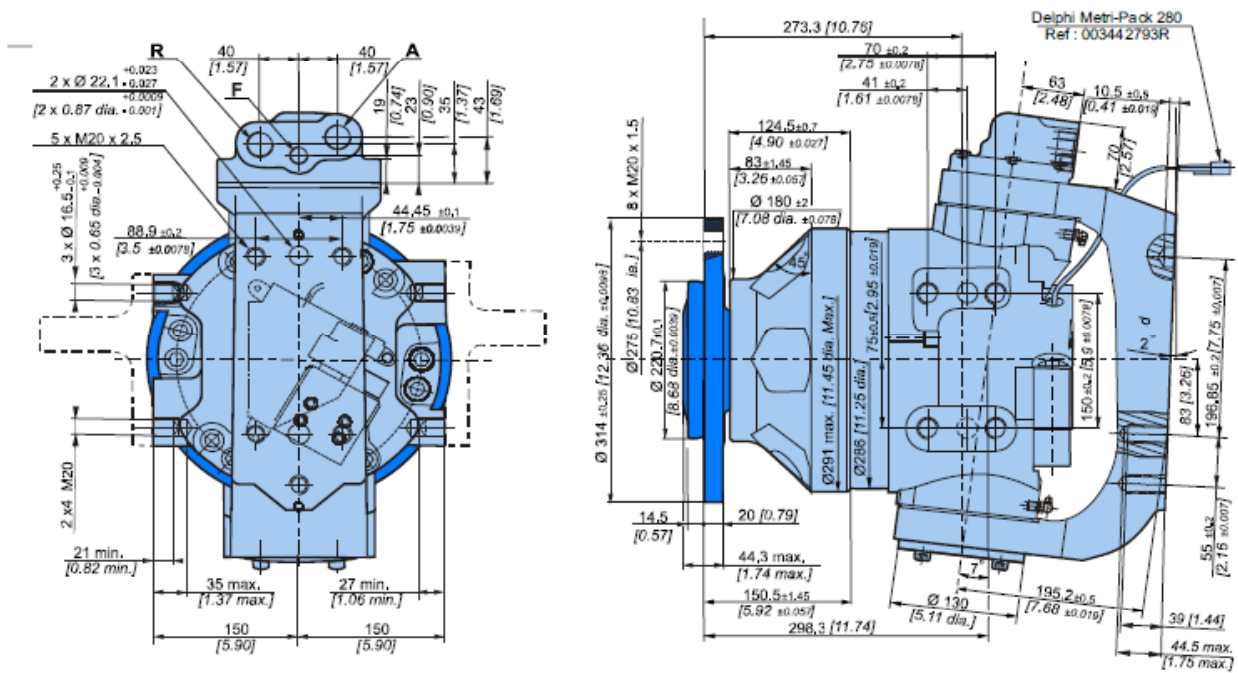

Exchange

When a coding request is made, you must specify information on the threshold of the selector and the valve.

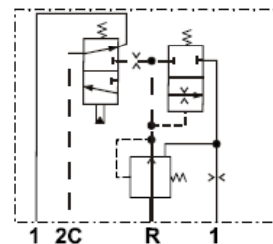
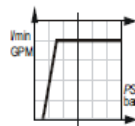
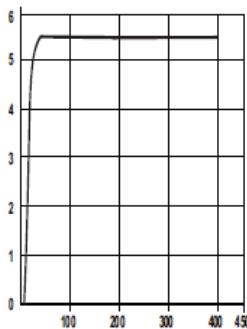

The exchange flow rate indicated on the basis of the supply pressure (P = 50 bar [725 PSI]) is constant (Q = 5.5 l/min [1.45 GPM]).



Load curves



The given load curves correspond to the conditions specified below. For load curves corresponding to your specifications, contact a Poclairn Hydraulics engineer.

Permissible radial loads

Test conditions :

Static :

- 150 bar [2175 PSI], code 9 displacement
- Max. axial stress = 15% of Fr
- Load radius = 719 mm [28.31 in]

Dynamic :

- 450 bar [6527 PSI], code 9 displacement
- Max. axial stress = 15% of Fr
- Load radius = 719 mm [28.31 in]

MG11

Service life of bearings

Test conditions :

L : Millions B10 revolutions at 150 bars (average pressure), with 25 cSt fluid, code 2 displacement, without axial load.

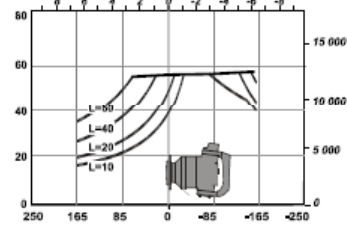
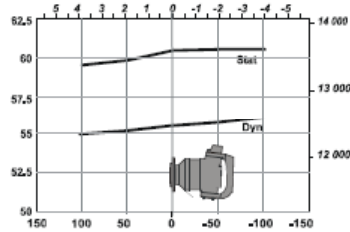
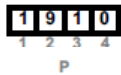
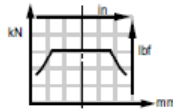

Permissible radial loads

Test conditions :

Static :

- 150 bar [2175 PSI], code 9 displacement
- Max. axial stress = 15% of Fr
- Load radius = 719 mm [28.31 in]

Dynamic :

- 450 bar [6527 PSI], code 9 displacement
- Max. axial stress = 15% of Fr
- Load radius = 719 mm [28.31 in]

MGE11

Service life of bearings

Test conditions :

L : Millions B10 revolutions at 150 bars (average pressure), with 25 cSt fluid, code 0 displacement, without axial load.

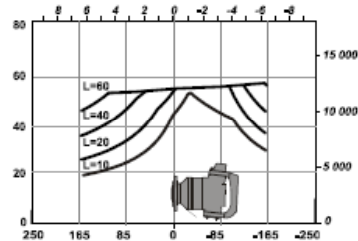
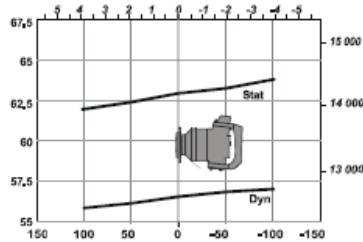
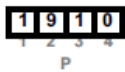
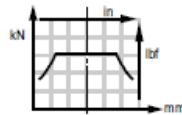

The service life of the components is influenced by the pressure. You must check that the combination of forces applied (Axial load / Radial load) is compatible with the permissible loads for the components, and that the resulting service lives of these components complies with the application's specifications. For an accurate calculation, consult your Poclairn Hydraulics application engineer.

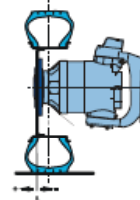

Efficiency

Overall efficiency

Average values given for guidance for code 0 displacement after 100 hours of operation with HV46 hydraulic fluid at 50°C [122°F].

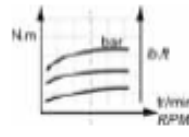
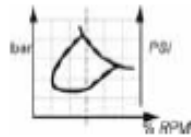

Actual output torque

MG11

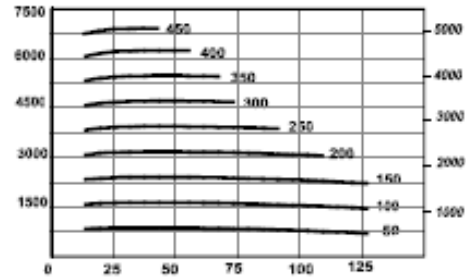
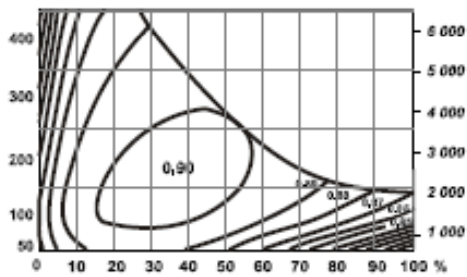

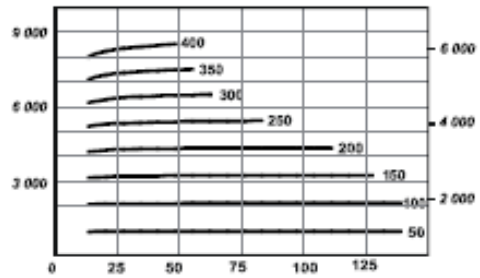
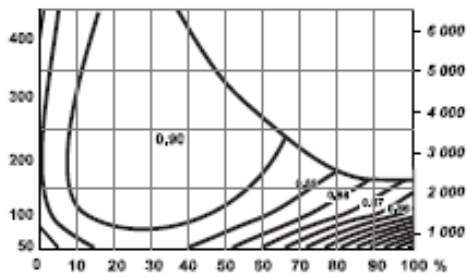

MGE11



The starting torque is taken to be approximately 85% of the first value for available pressure. For a precise calculation, consult your Poclain Hydraulics application engineer.

Wheel rim mountings

	Classe		N.m	[lb.ft]
8xM20x1.5	12,9		690	[509]

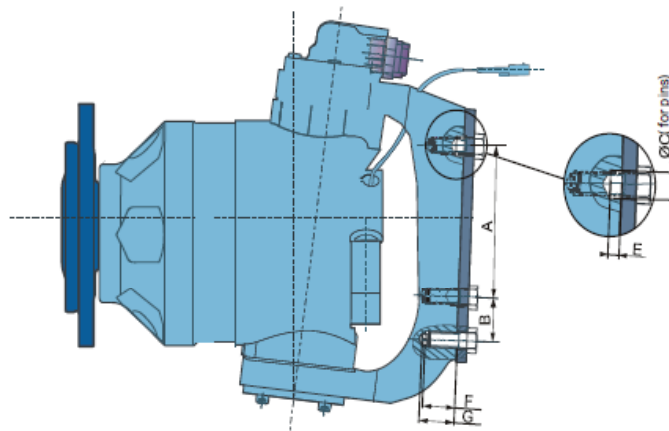

(*) The tightening torques are given for the indicated loads.

Chassis mounting



Take care over the immediate environment of the connections.

A (1)	B (1)	2xØC (2)	E (3)	F max.	G (4)
mm [in]	mm [in]	mm [in]	mm [in]	mm [in]	mm [in]
196,85 [7,75]	55 [2,17]	22,1 [0,87]	10,5 [0,41]	39 [1,54]	44,5 [1,75]

	Classe		N.m	[lb.ft]
5xM20x2.5	12.9		690	[509]

(1) $+0.2 [+0.0078]$
 $-0.2 [-0.0078]$ (2) $+0.023 [+0.0009]$
 $-0.0027 [-0.0010]$ (3) $+0.5 [+0.019]$
 $-0.5 [-0.019]$

(*) The tightening torques are given for the indicated loads.



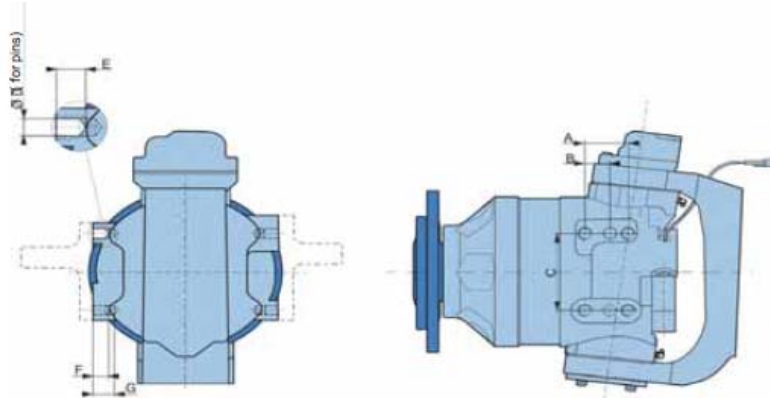

Pins are used to take tangential stress.

Steering attachment



A (1) mm [in]	B (1) mm [in]	C (1) mm [in]	3x ØD (2) mm [in]	E mm [in]	F mm [in]	G mm [in]
70 [2,76]	41 [1,61]	150 [5,91]	16,5 [0,65]	27 [1,06]	21 [0,83]	35 [1,38]

	Classe		N.m [lb.ft]	
			N.m	[lb.ft]
8x M20x2.5	12,9		690	[509]

(1) + 0.2 [+0.0078]
- 0.2 [-0.0078]

(2) + 0.25 [+0.0098]
- 0.1 [-0.0039]

(*) The tightening torques are given for the indicated loads.



Pins are used to take tangential stress.

Steering angle

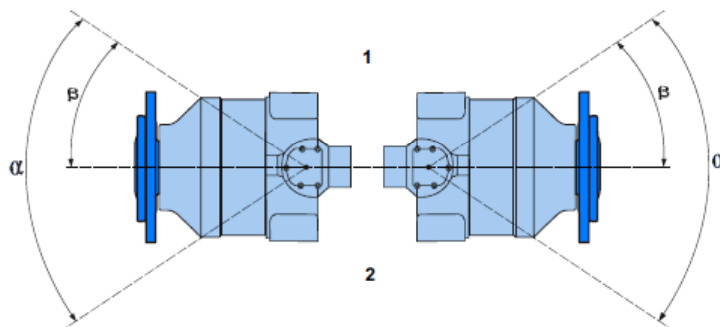

Attachment(s)	α	β
	Max.	Min.
1	80 °	40 °
2	74 °	37 °

Hydraulic connections

connections

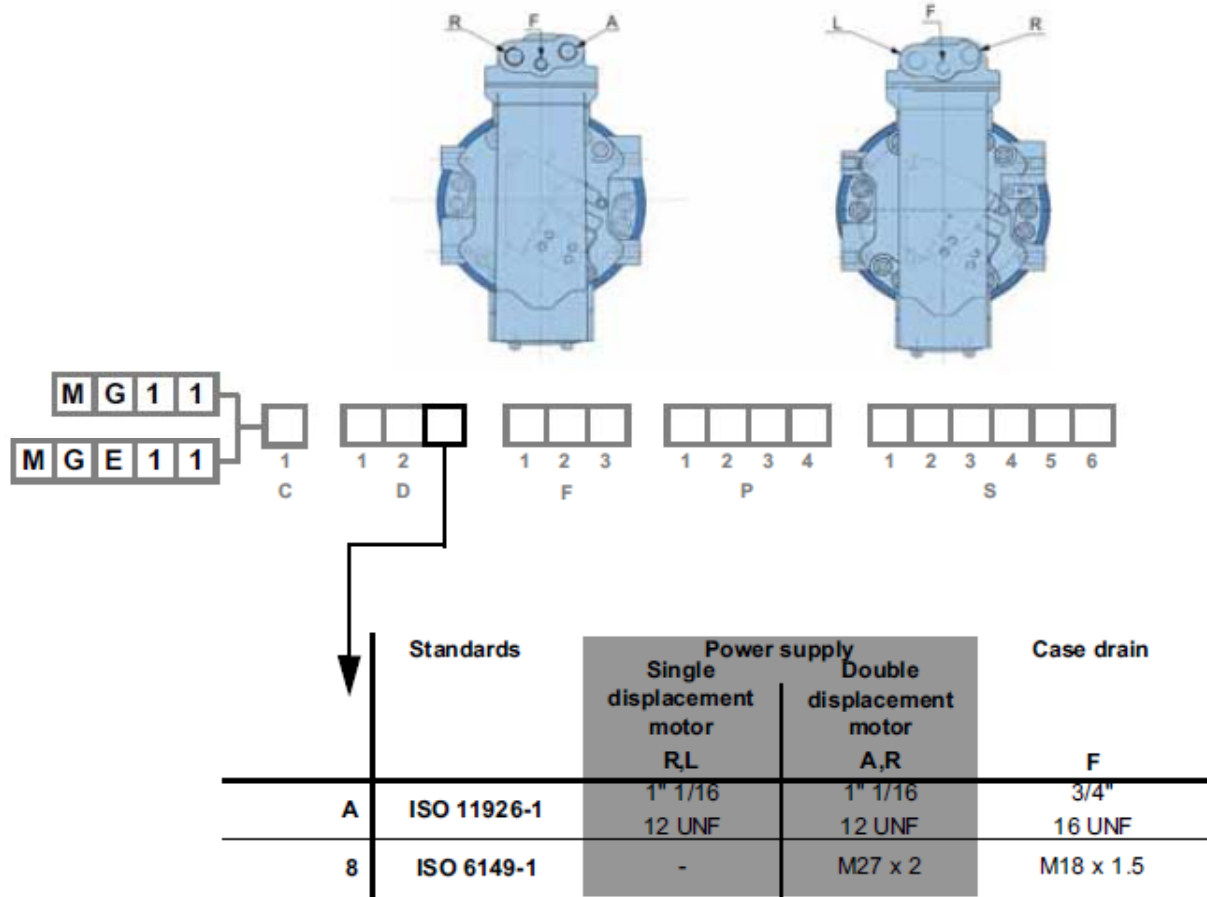

You are strongly advised to use the fluids specified in brochure "Installation guide" N° 801478197L.



To find the connections' tightening torques, see the brochure "Installation guide" N° 801478197L.



OPTIONS

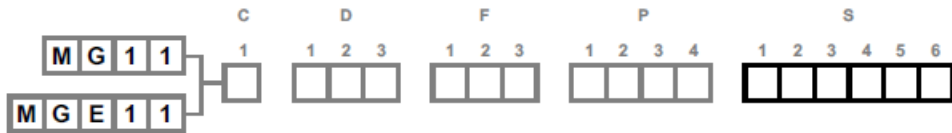

You can accumulate more than one optional part. Consult your Poclair Hydraulics sales engineer.

2 - S - 8 - Installed speed sensor or predisposition

Designation	C
T4 Speed sensor installed	2
TR Speed sensor installed	S
Predisposition for speed sensor	8

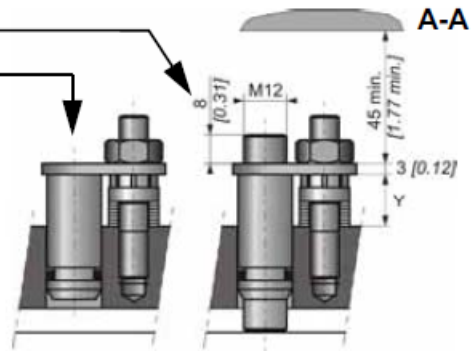
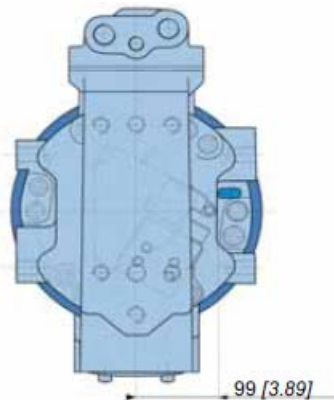

Max. length Y= 13.5
Standard number of pulses per revolution= 56



Look at the "Mobile Electronic" N° A01889D technical catalogue for the sensor specifications and its connection.



To install the sensor, see the "Installation guide" brochure No. 801478197L.

7 - Diamond™

Special treatment of the motor core which considerably increases its strength, making the motor much more tolerant to temporary instances of the operating conditions being exceeded.

E - Reinforced sealing

Requires reinforcement of shaft bearings.