



## COILS GUIDE



## STANDARD COILS AND PROPORTIONAL VALVE COILS

### COMMON WINDING SPECIFICATIONS

08, 80 Size Coil Data (14.7 Watts)		
Volts	Resistance (DC) @ 20°C Ohms	Initial Current Draw Amps
DC Service		
6*	2.46	2.44
10	6.8	1.47
12	9.8	1.22
20*	27.2	0.74
24	39.3	0.61
30*	61.4	0.49
36	88.3	0.41
48	156.6	0.31
72*	352.4	0.20
AC Service		
24	31.2	0.61
115	765.5	0.13
230	3035.0	0.06

\*Special Order Coils

10, 38, 58, 12, 52, 16, 56 Size Coil Data (20 Watts)		
Volts	Resistance (DC) @ 20°C Ohms	Initial Current Draw Amps
DC Service		
6*	1.8	3.33
10	4.8	2.08
12	7.2	1.67
20*	19.0	1.05
24	28.8	0.83
30*	43.2	0.69
36	64.8	0.56
48	110.2	0.44
72*	249.8	0.29
AC Service		
24	23.6	0.83
115	568.0	0.17
230	2304.0	0.09

\*Special Order Coils

70 Size Coil Data Proportional Coil Data		
Volts	Resistance (DC) @ 20°C Ohms	Nominal I-Max. Current Draw Amps
12	5.0	1.50
24	20.0	0.75

EHPR Coil Data Proportional Coil Data		
Volts	Resistance (DC) @ 20°C Ohms	Nominal I-Max. Current Draw Amps
10	3.1	1.50
12	5.4	1.20
20	12.5	0.75
24	21.7	0.60

### COIL INFORMATION

- AC service coils are internally rectified, and can be used in 50 or 60 cycle (Hz) lines.
- Special voltages and terminations are available for OEM applications; consult factory.
- Coil should always be installed with lettering facing up.
- Standard coils are not hermetically sealed. For applications requiring water- or weather-resistant coils, see page 3.400.1
- AC voltage service with transient surges over 1000 volts may require that a varistor be placed in parallel at the coil.
- EG option coils do not use ground terminal. Pins 1 and 2 are not polarity-sensitive.

Voltage	Varistor Part No.	Joule Rating Required
115	GE: V150LA10A Siemens: S10R150 or equivalent	45 minimum
230	GE: V250LA40A Siemens: S20R250 or equivalent	130 minimum

### COIL ACCESSORIES

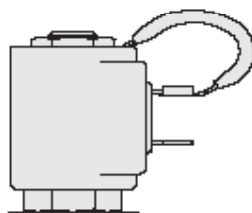

**Coil Ground Strap  
for DS Coils**  
HF Part No. 6502200

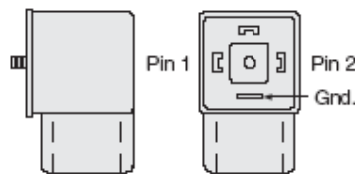

**DIN 43650  
1/2" Conduit to Connector**  
HF Part No. 6110001

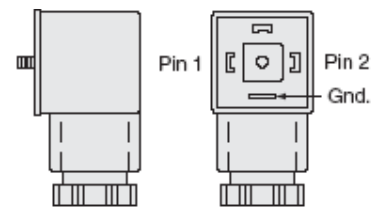

**DIN 43650  
Cable Gland PG 9  
(7 mm nominal cable diameter)**  
HF Part No. 6110002  
**or** Cable Gland PG 11  
(9 mm nominal cable diameter)  
HF Part No. 6110005

## STANDARD COILS AND PROPORTIONAL VALVE COILS

### SERIES 08, 80, 88, 98 COIL INFORMATION

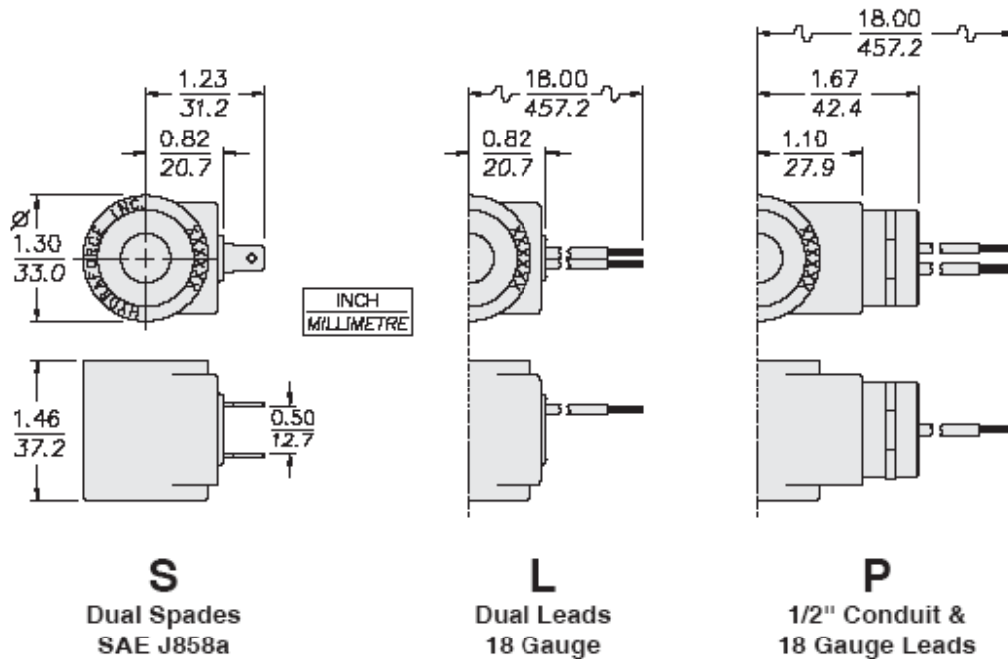

Voltage	Part Number Suffix		
	S	L	P
10 VDC	6301010	6302010	
12 VDC	6301012	6302012	6305012
24 VDC	6301024	6302024	6305024
36 VDC	6301036	6302036	
*24 VAC			6315024
*115 VAC			6315115
*230 VAC			6315230

\*Rectified

Coil Weight: 110 g. (4.0 oz.)

## STANDARD COILS AND PROPORTIONAL VALVE COILS

### SERIES 08, 80, 88, 98 COIL INFORMATION

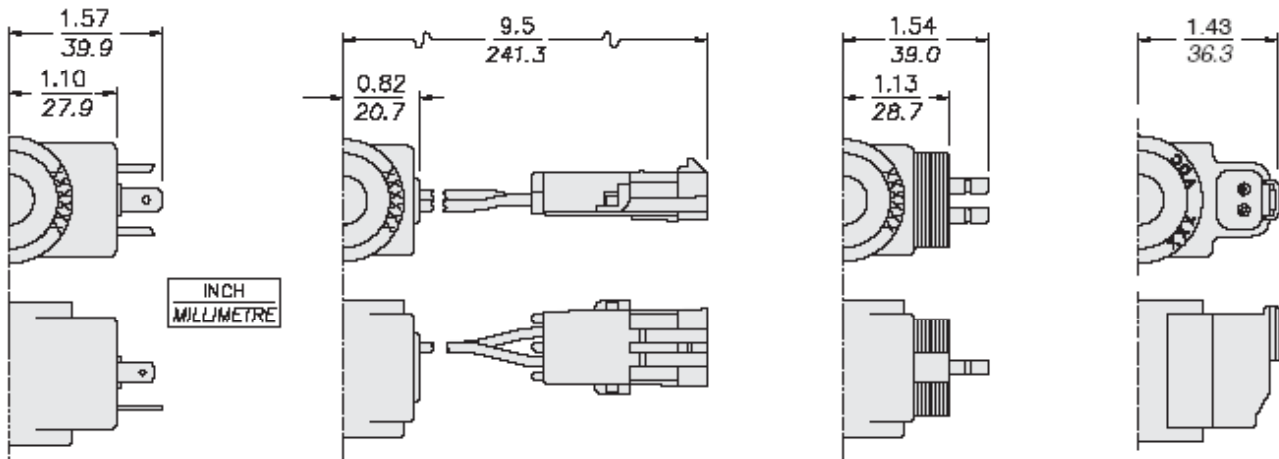

**G**

**DIN 43650  
Connector**

Pins 1 and 2 are not  
polarity-sensitive.  
Ground pin is not used.

**W**

**Dual 18 Gauge Leads with  
Weather Pack® Connector**

For use with Packard  
part no. 12015792 male plug

**K**

**Kostal  
Connector**

DK Coils; U.K.  
availability only.

**DR**

**Integral Deutsch  
Connector**

DR Models without Diode  
DR/D Models with Diode  
DR/Z Models with Zener Diode

**Mating Connector:**  
Deutsch No. DT06-2S  
HF Part No. 4001417

Voltage	Part Number Suffix					
	G	W	K	DR	DR/D	DR/Z
10 VDC	6306010	6309410				
12 VDC	6306012	6309412	6348812	4301512	4301872	4301852
24 VDC	6306024	6309424	6348824	4301524	4301874	4301854
36 VDC	6306036	6309436				
*24 VAC	6316024					
*115 VAC	6316115					
*230 VAC	6316230					

\*Rectified

Coil Weight: 110 g. (4.0 oz.)

STANDARD COILS AND PROPORTIONAL VALVE COILS

SERIES 10, 12, 10, 38, 58 COIL INFORMATION

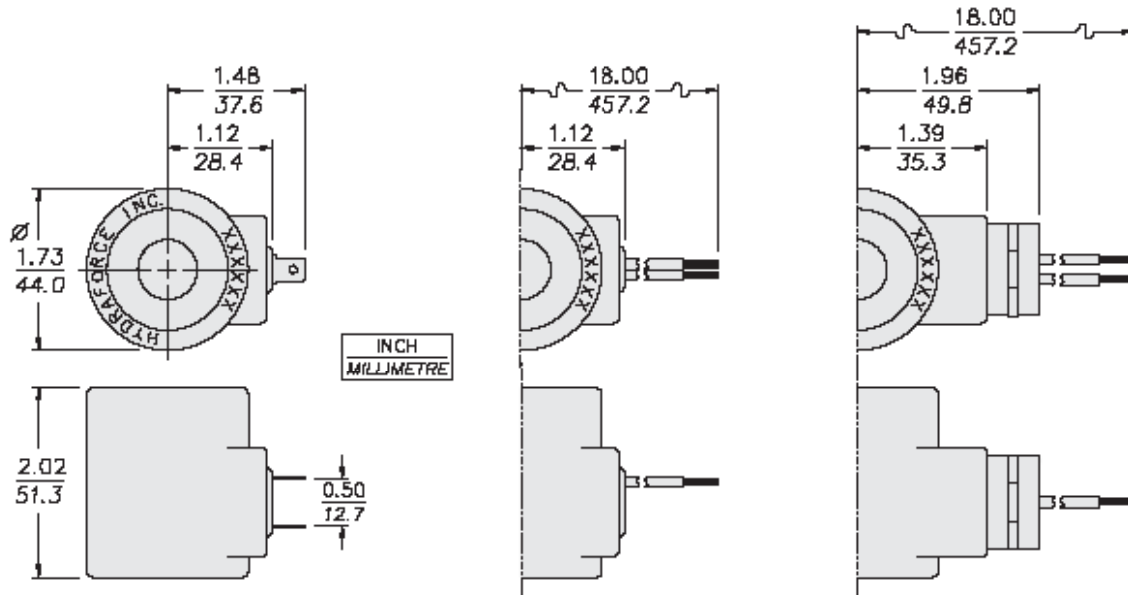

**S**  
Dual Spades  
SAE J858a

**L**  
Dual Leads  
18 Gauge  
Optional 36-inch leads  
available. Consult factory.

**P**  
1/2" Conduit &  
18 Gauge Leads

Voltage	Part Number Suffix		
	S	L	P
10 VDC	6351010	6352010	
12 VDC	6351012	6352012	6355012
24 VDC	6351024	6352024	6355024
36 VDC	6351036	6352036	
*24 VAC			6365024
*115 VAC			6365115
*230 VAC			6365230

\*Rectified

Coil Weight: 270 g. (9.6 oz.)

# STANDARD COILS AND PROPORTIONAL VALVE COILS

## SERIES 10, 12, 10, 38, 58 COIL INFORMATION

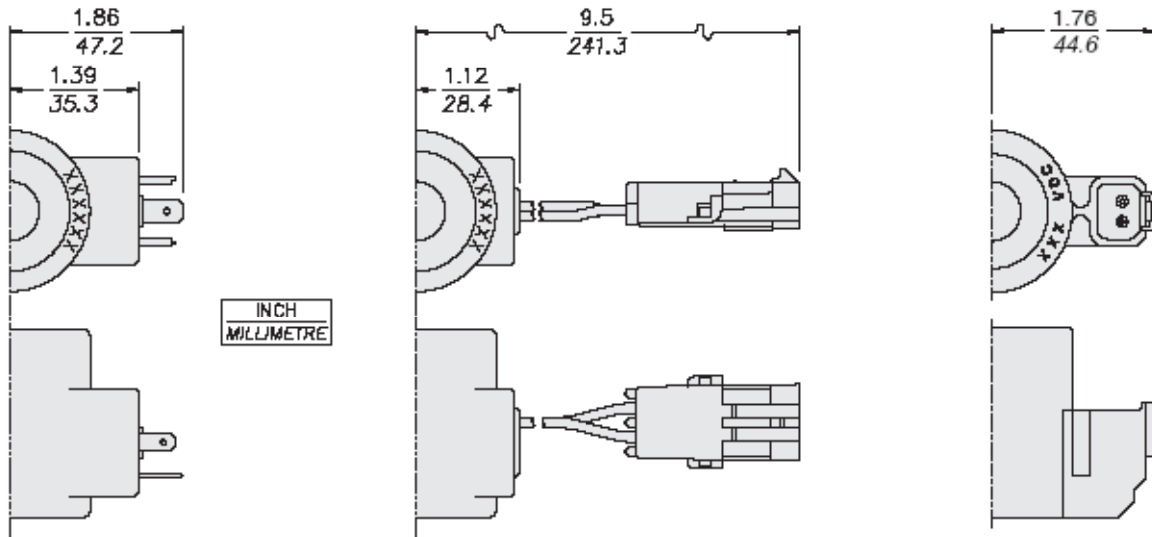

**G**

**DIN 43650 Connector**

Pins 1 and 2 are not polarity-sensitive.  
Ground pin is not used.

**W**

**Dual 18 Gauge Leads with Weather Pack® Connector**

For use with Packard part no. 12015792 male plug

**DR**

**Integral Deutsch Connector**

DR Models without Diode  
DR/D Models with Diode  
DR/Z Models with Zener Diode

**Mating Connector:**  
Deutsch No. DT06-2S  
HF Part No. 4001417

Voltage	Part Number Suffix				
	G	W	DR	DR/D	DR/Z
10 VDC		6359410		4301891	
12 VDC	6356012	6359412	4301612	4301892	4301862
20 VDC				4301893	
24 VDC	6356024	6359424	4301624	4301894	4301864
36 VDC	6356036	6359436			
*24 VAC	6366024				
*115 VAC	6366115				
*230 VAC	6366230				

\*Rectified

Coil Weight: 270 g. (9.6 oz.)

## PROPORTIONAL VALVE COILS

### SIZE 70 COIL INFORMATION

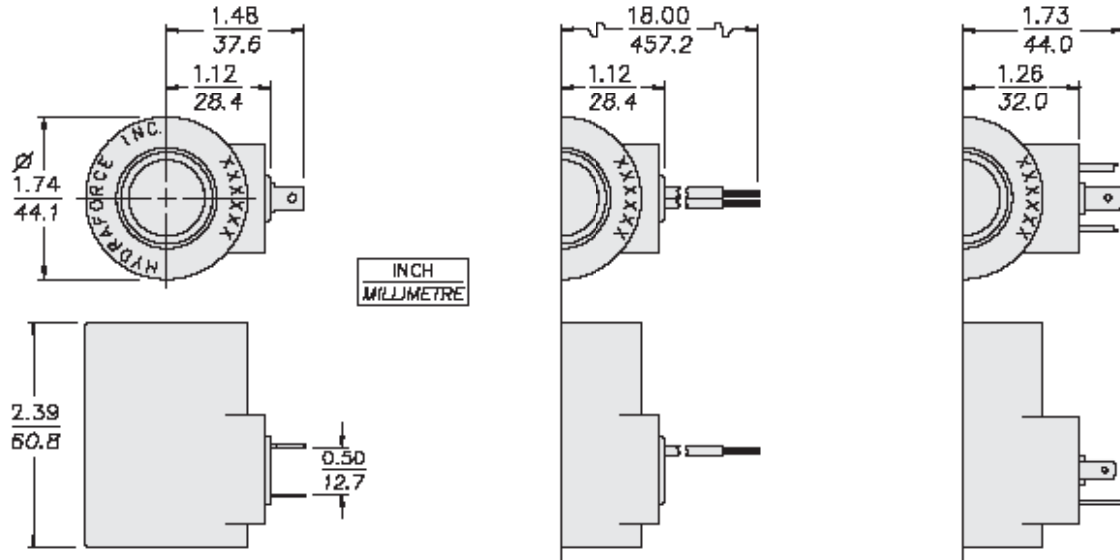

**S**  
Dual Spades  
SAE J858a

**L**  
Dual Leads  
18 Gauge

**G**  
DIN 43650  
Connector  
Pins 1 and 2 are not  
polarity-sensitive.  
Ground pin is not used.

Voltage	Part Number Suffix		
	S	L	G
12 VDC	6507112	6507212	6507612
24 VDC	6507124	6507224	6507624

Coil Weight: 320 g. (11.2 oz.)

## PROPORTIONAL VALVE COILS

### SERIES EHPR08 COIL INFORMATION

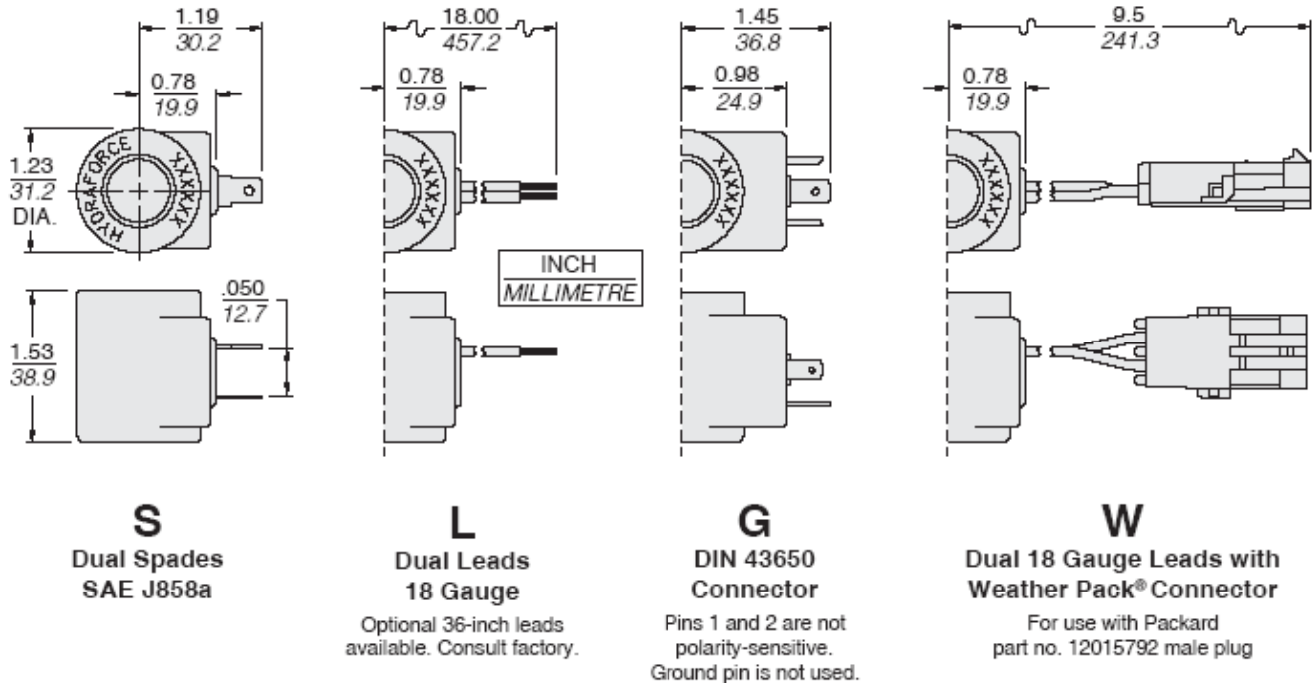

Voltage	Part Number Suffix			
	S	L	G	W
12 VDC	6451112	6451212	6451612	6451512
24 VDC	6451124	6451224	6451624	6451524

Coil Weight: 110 g. (4.0 oz.)



## SERIES E, ENVIROMENTAL COILS

### NEW SERIES E WATER-PROOF / WEATHER-RESISTANT SOLENOID VALVE COILS

New Series E coils are the latest innovation in coil technology from Hydraforce. They are designed to meet the demanding requirements of mobile and industrial applications where weather resistance is required. Models with Deutsch DT and Metri-Pack® integral connectors and new dual leadwire models meet or exceed all IP69K standards for weather resistance, offering superior reliability under the most demanding conditions. Series E coils have passed what is known in the construction, agricultural and mobile equipment markets as the "Thermal Shock Dunk Test."

Series E coils feature a new, fully encapsulated coil winding technology. Deutsch and Metri-Pack® connectors are molded into the coil encapsulation, assuring IP69K weather resistance. An external metal shell serves as the element to concentrate the magnetic flux for the coil winding and also functions as a rugged container for the coil. No O-rings or waterproofing kits are required.

Models are available to fit most HydraForce valves. In most applications, these coils can be used to retrofit HydraForce valves already in field operation and will offer superior weather resistance.

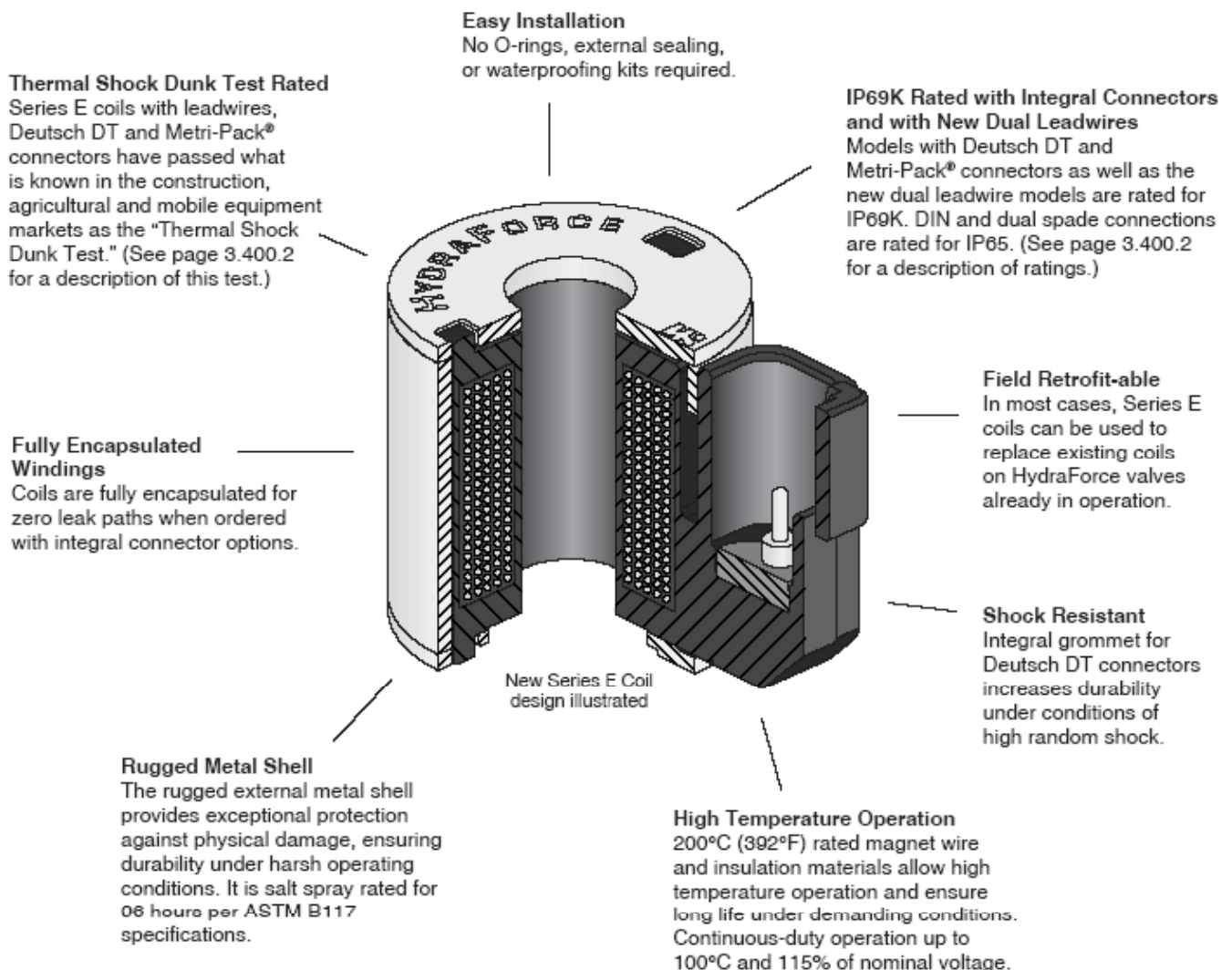

NOTE: Some coils, including those manufactured prior to 1-1-04, may differ slightly in construction from this illustration. See page 3.400.17

## SERIES E, ENVIRONMENTAL COILS

### IMPROVING DURABILITY TO ASSURE LONG LIFE IN THE HARSHTEST ENVIRONMENTS

HydraForce has made design changes to the industry-leading environmentally-hardened Series E coils. The new design provides longer life under high-temperature conditions, as well as easier and more convenient interchange with our Series D standard-duty coils.

#### The Story Behind the Ratings

To appreciate the performance of the new Series E coils, it is helpful to have a working knowledge of the testing conducted to assure coil life in the harshest environments. Many OEMs request a coil that is IP67 or IP69 rated. These ratings do not address the issue of the effect of high temperatures on coil life and operation. Therefore they are of limited value in evaluating the suitability of a coil for use in typical mobile equipment applications.

**Why temperature matters:** When a coil is heated, the air inside the coil expands, creating internal pressure, causing the heated air to attempt to exit the coil. If the coil is then submerged in cold water, the air within the coil cools and contracts, drawing water into the coil through any seams or voids in the coil encapsulant. Eventually the water will find its way into the winding area, causing the coil winding to corrode or short-circuit, resulting in coil failure.

IP ratings are international specifications for electrical equipment which define various levels of protection against failure resulting from contamination by water or other foreign substances. The IP67 rating is based on submerging the coil in one meter of water for 30 minutes. The coil is then inspected for evidence of water infiltration. The IP67 specification loosely states that "ingress of water in quantities causing harmful effect shall not occur." The exact meaning of the phrase "harmful effect" is not precisely defined, and is therefore open to some interpretation. In this test, the coil is not subjected to high temperatures, so the effects of thermal stress are not considered.

The IP69 rating, which is currently only part of the DIN version of this specification, first requires that the coil pass the test for IP67 as described above. Beyond that, the coil and its integral electrical connector are subjected to a rigorous high-pressure water spray. The water is mixed with detergent, is held at a temperature of 80°C., and is sprayed at the coil from a distance of 100 mm (4 inches) at a pressure of 100 bar (1450 psi). Again, the specification does not precisely define the amount of water ingress that would be considered unacceptable.

#### HydraForce Ratings

Working with major mobile equipment OEMs, HydraForce has developed even more rigorous tests that are designed to assure that our coils will perform reliably under the harshest real-world application conditions. Both our original and our new Series E coils meet or exceed the requirements of what is known as the "Thermal Shock Dunk Test." In this test the coil is thermally "soaked" for two hours in an ambient temperature of 100°C. The coil is then immersed immediately in a 0°C salt-water bath for two hours. This procedure is repeated ten times. The coil is then inspected for water ingress. By Hydraforce's standards, the coil is considered to have passed this test if there is NO detectable water ingress, as determined by visual inspection and a "high pot" test. This standard requires a totally sealed coil that is impervious to moisture infiltration, even under widely varying ambient thermal conditions.

**The new Series E coils can now withstand at least 10 cycles of the "Thermal Shock Dunk Test."**

In addition to the requirements of the industry-recognized, "Thermal Shock Dunk Test," described above, HydraForce further tests these coils for durability against failure due to vibration, as well as against failure due to the application of voltage above the coil's standard duty rating while it is simultaneously subjected to continually varying ambient temperatures.

Beyond enhancing the durability of the coils, we have decreased the wattage by approximately 10%. This reduces the power consumption and also allows the operating temperature range to be extended. The new design also improves the ease and convenience of interchanging these coils with HydraForce's Series D (standard duty) coils, the original Series E coils, as well as the older "W-style" waterproof option. The new Series E coils use the same retaining nuts as the Series D coils, simplifying interchangeability, inventory and assembly requirements and procedures.

See page 3.400.17 for detailed information describing the differences between the original Series E coils and the new Series E coils, including part number cross-references for the coils, the retaining nuts, and the spacers used on the dual-solenoid valves.

## SERIES E, ENVIROMENTAL COILS

### OUR COIL TESTING PROGRAM IS THE MOST STRINGENT AND RIGOROUS IN THE INDUSTRY

#### 1.) Extended Thermal Shock Immersion Test – IP67 Ref. Exceeds IP67 per standard EN60529

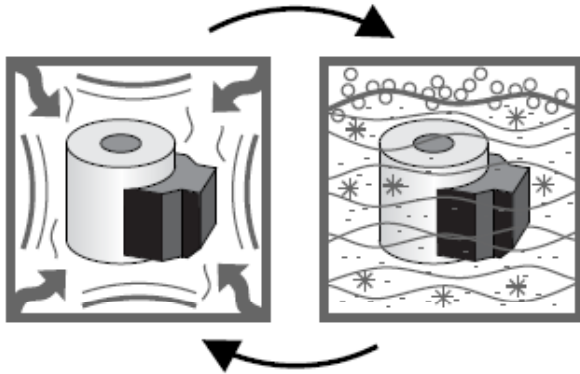

The purpose of this test is to try to induce cracks in the encapsulation of the coil.

The coil is heated for two hours at an ambient temperature of 105°C (±5°C), then immediately immersed in a solution of water, detergent and salt at a temperature of 0° to 5°C for two hours. The coils is then visually inspected for cracks and water penetration. This process is repeated ten times.

#### 2.) Salt Spray Test DIN 50 021 Level 1 (Ref: Standard ASTM B117)

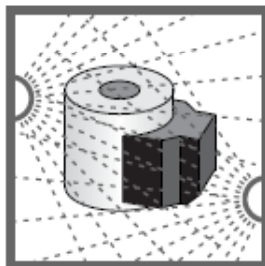

This accelerated test is designed to simulate the corrosive environment that the coil will encounter during the life of the vehicle.

The coil is subjected to a continuous salt spray as per ASTN B117 for a period of 20 hours. The coil is then rinsed and dried.

#### 3.) Inorganic Dust Test ANSI/ASAE EP455 Section 5.3



This tests for the effects of dust on the coil.

The coil is placed in a dust chamber containing the equivalent of air cleaner fine dust. Sufficient air movement is provided to maintain a minimum 0.88g per cubic meter with the coil positioned in its normal mounting position. The test is run for a minimum of 24 hours.

#### 4.) Vibration Test

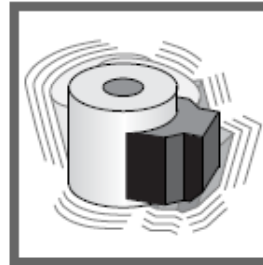

This accelerated test simulates random vibration that the coil will encounter when used on heavy-duty equipment.

Functional performance is monitored under the following vibration levels shown in the table below for 72 hours in each of the three perpendicular axes. The coil is then checked for impaired function, loose parts and fatigue cracks induced by the test.

#### Vibration Test Profile:

Frequency (Hz)	Measured PSD (G <sup>2</sup> /Hz)	Acceleration Factor	Accelerated Test PSD (G <sup>2</sup> /Hz)
20	0.422	x 2	0.844
25	0.781	x 2	1.562
76	0.174	x 2	0.348
137	0.00283	x 7.2	0.020374
216	0.00073	x 7.2	0.005256
261	0.00119	x 7.2	0.008568
320	0.00042	x 7.2	0.003024
399	0.0000415	x 7.2	0.000298
626	0.0000265	x 7.2	0.0001908
712	0.000452	x 7.2	0.0032544
799	0.0000491	x 7.2	0.00035352
966	0.00117	x 7.2	0.008424
1424	0.00000965	x 7.2	0.00006948
1597	0.00012	x 7.2	0.000864
1996	0.0000154	x 7.2	0.0001108



## SERIES E, ENVIROMENTAL COILS

### COIL TESTING PROGRAM (cont'd)

#### 5.) Operating Shock



This test simulates sudden, severe shock induced when the vehicle is driven over rough terrain.

The coil must withstand a 5 ms pulse of 490 m/sec<sup>2</sup> (50 g). Impaired function, loose parts, and fatigue cracks caused by this test result in part rejection. The test is repeated a total of five times in each of the three perpendicular axes.

#### 6.) Chemical Resistance

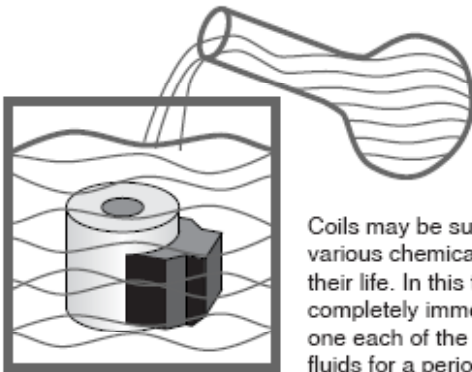

Coils may be subjected to various chemicals throughout their life. In this test a coil is completely immersed in only one each of the following fluids for a period of 5 minutes. Twelve coils are used at a time.

After immersion the coils are heated for four hours at 50°C and the cycle is repeated for a total of ten trials. Impaired function as a result of this test is cause for failure.

- Gasoline
- Engine Oil
- Hydraulic Fluid
- Bearing Grease
- Antifreeze
- Fertilizer (28% Nitrogen with ammonium nitrate and urea at a pH of 5)
- Diesel Fuel
- Phosphate Wash
- Degreaser
- Windshield Washer Fluid
- Battery Acid

#### 7.) Bench Handling Shock



This test simulates the effects of dropping a coil while it is being handled.

The coil is dropped from a distance of 450mm (±5mm) onto a solid oak bench top at least 44mm thick. The test is repeated by dropping the coil once on all practical edges and faces. Impaired function as a result of this test is cause for rejection.

#### 8.) Storage Temperature

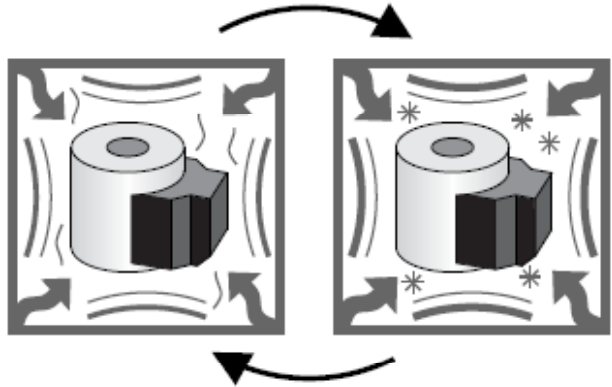

This test simulates the effects of storage in extreme temperatures for some time.

While not in operation, the coil is subjected to +105°C and then -55°C for 20 hours each. Impaired function as a result of this test is cause for rejection.

#### 9.) Humidity

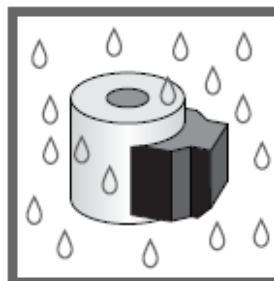

This test simulates the effects of relative humidity on the coil.

The coil is soaked at 40°C and 95% relative humidity for 168 hours each while the coil is not in operation. Impaired function as a result of this test is cause for rejection.

## SERIES E, ENVIROMENTAL COILS

### COIL TESTING PROGRAM (cont'd)

#### 10.) Continuous Immersion – IP68 Ref. Standard EN60529

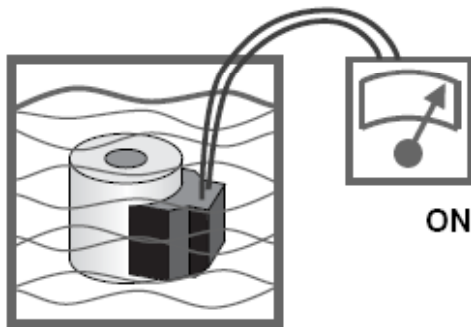

In this test the coil is immersed while powered on. The coil is immersed in 1 meter of water at an ambient temperature of 25°C (±5°C) for 120 hours while powered according to the chart below. Impaired function as a result of this test is cause for rejection.

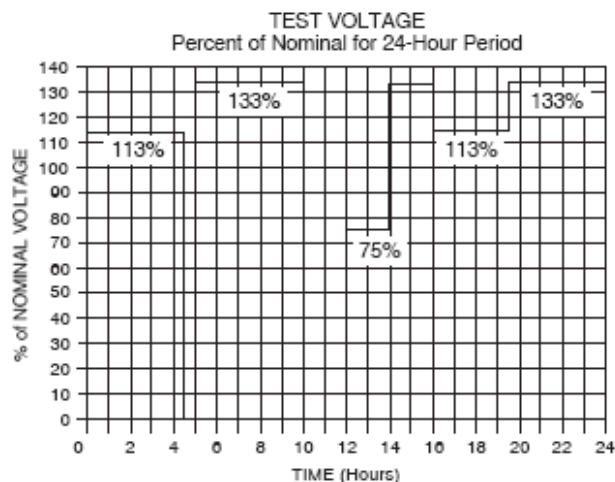

#### 11.) Maximum Load Cycling



This accelerated test simulates temperature cycling to induce cracks or separation between components of the coil.

Coils are installed in an environmental chamber set to 85°C and 133% of nominal voltage is applied for 1 hour. After 1 hour, the power is immediately switched off and back on within 2 seconds. 133% of nominal voltage is then applied for a period of 5 minutes. After 5 minutes, power is immediately switched off and then back on within 2 seconds. This 5-minute cycle is repeated for a total of 168 hours (power is turned off and on within 2 minutes every 5 minutes). Cracks in the encapsulation, separation in components, or impaired function are cause for rejection.

#### 12.) Jump Start

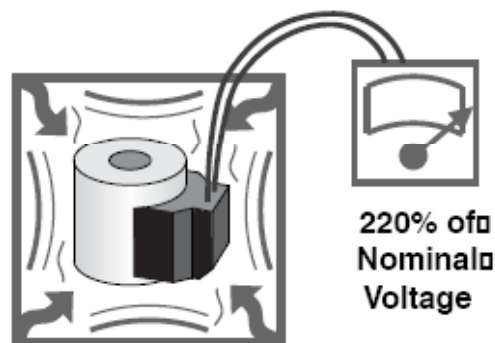

This test simulates the voltage required to jump start heavy equipment.

The coil is thermally soaked in an environmental chamber at 70°C for 2 hours. It is then subjected to 220% of nominal voltage for 5 minutes.

## SERIES E, ENVIROMENTAL COILS

### COIL TESTING PROGRAM (cont'd)

#### 13.) High Pressure Cleaning – IP69K Ref. Standard DIN 40 050, part 9

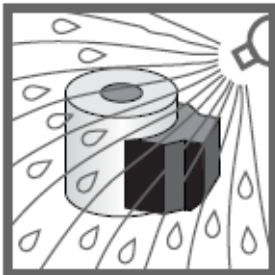

This test simulates high-pressure steam-jet cleaning of a component.

#### 14.) Combined Operating Voltage, Humidity and Temperature



This test simulates the combined effects of some of the previous tests.

The coil is simultaneously subjected to the voltage, temperature and humidity profiles shown in the graphs below. The cycle is repeated for a total of 600 hours (25 days). The coils are inspected every 20 cycles for cracks in the encapsulation, separation of components, or impaired function as a result of this test. Any induced flaws will result in rejection.

#### 14.) Combined Operating Voltage, Humidity and Temperature (continued)

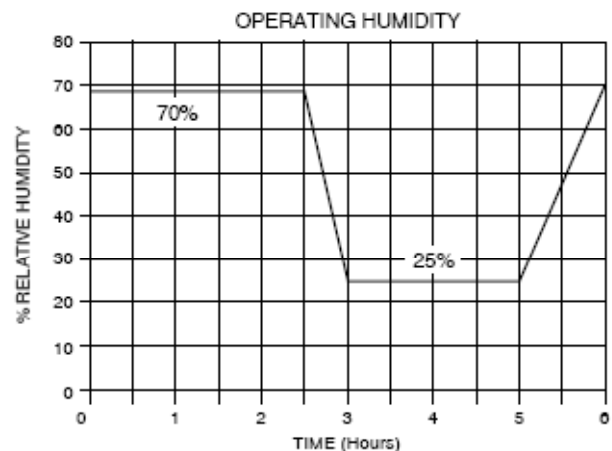
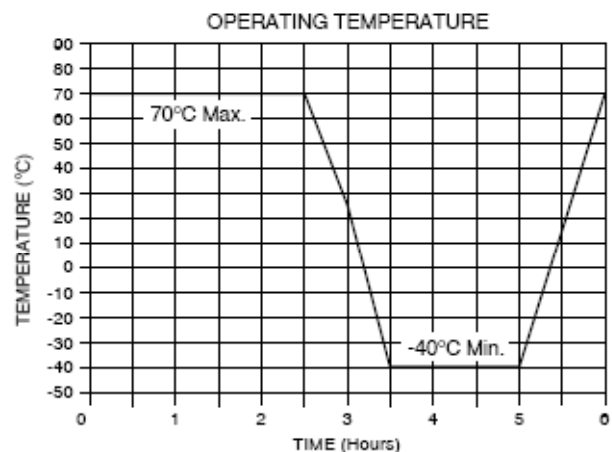
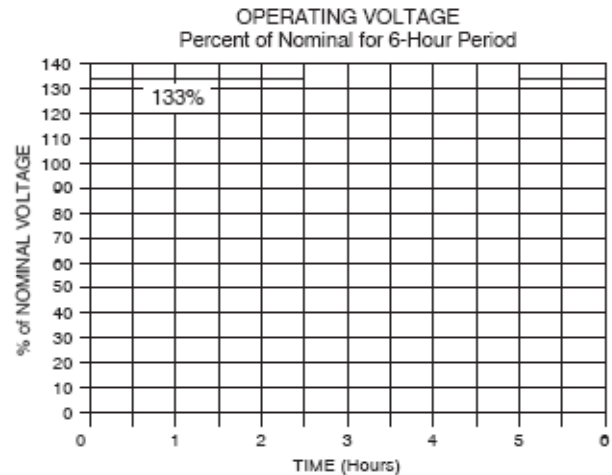

## SERIES E, ENVIROMENTAL COILS

### 08-SIZE SERIES E COILS (also for use on 98-size screw-in spool-type valves)

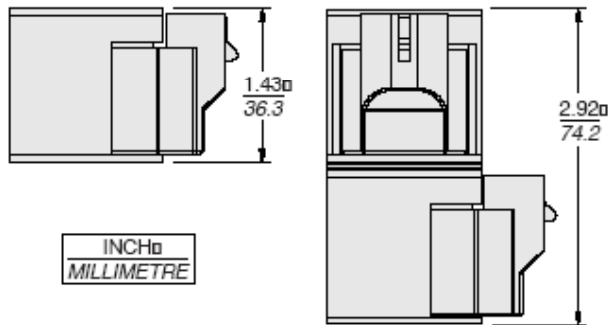
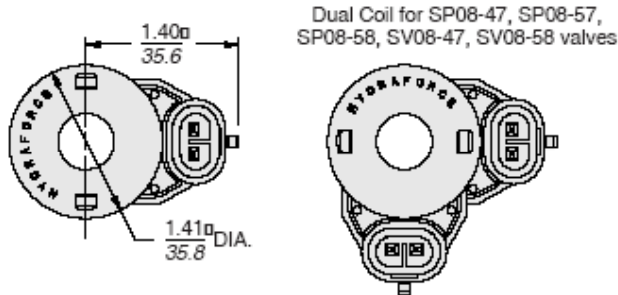

INCH  
MILLIMETRE

### EY

IP69K Rated 08-Size Coil  
Thermal Shock Dunk Test Rated Coil  
Metri-Pack® 150 Connector

Mating Connector: Delphi Packard No. 12052641; HF Part No. 6110119

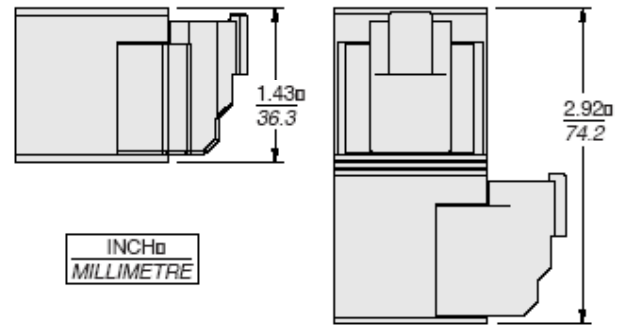
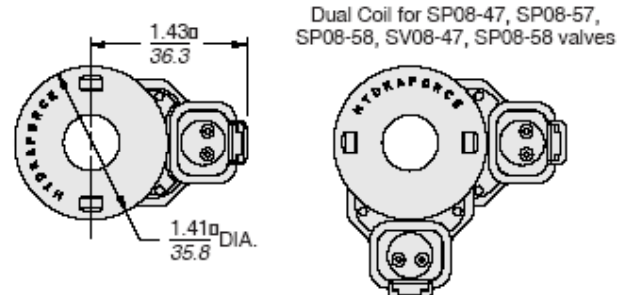

INCH  
MILLIMETRE

### ER

IP69K Rated 08-Size Coil  
Thermal Shock Dunk Test Rated Coil  
Deutsch DT04-2P Connector

Mating Connector: Deutsch No. DT06-2S — HF Part No. 4001417

EY Coil Part No.	EY/Z* Coil Part No.	ER Coil Part No.	ER/Z* Coil Part No.	Operating Voltage	Resistance at 20°C	Initial Current Draw	Power	Coil Weight
4303410	4303810	4303610	4304010	10 VDC	6.2 ohms	1.6 amps	15.9 watts	136 g. (4.8 oz.)
4303412	4303812	4303612	4304012	12 VDC	8.8 ohms	1.4 amps	17.2 watts	136 g. (4.8 oz.)
4303420	—	4303620	4304020	20 VDC	23.9 ohms	0.8 amps	15.3 watts	136 g. (4.8 oz.)
4303424	4303824	4303624	4304024	24 VDC	33.8 ohms	0.7 amps	16.6 watts	136 g. (4.8 oz.)

\* Models with Zener Diode

Note: Electrical specifications for Series E coils differ from those for standard HydraForce coils. (Refer to page 3.200.1 for standard coil specifications.)

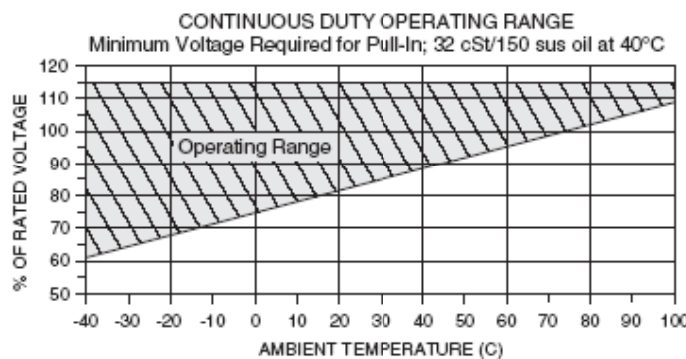

## SERIES E, ENVIROMENTAL COILS

### 08-SIZE SERIES E COILS (also for use on 98-size screw-in spool-type valves)

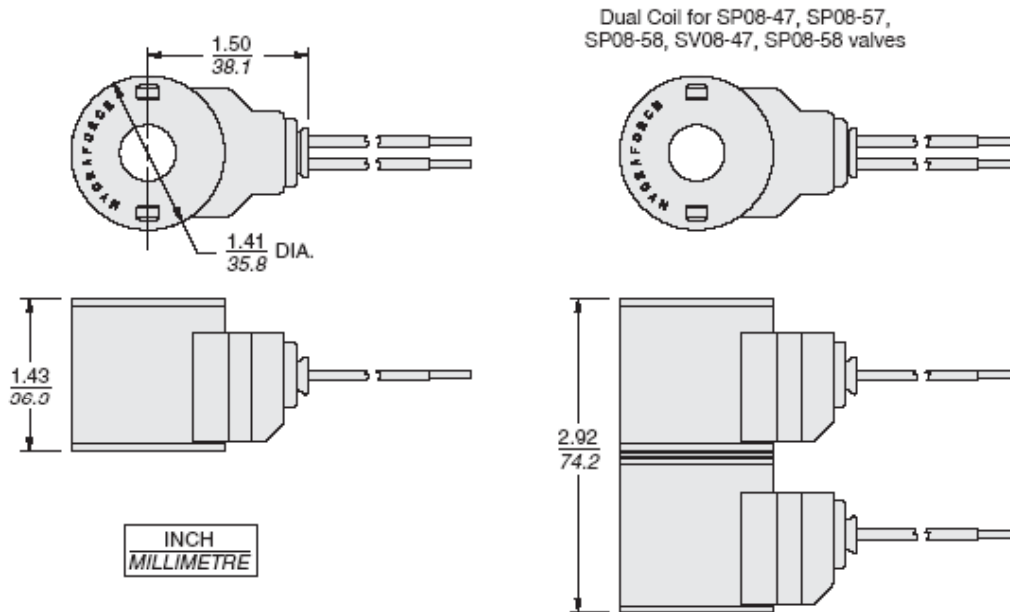

## EL

IP69K Rated 08-Size Coil  
Thermal Shock Dunk Test Rated Coil

EL Coil 36" Wire Part No.	EL Coil 18" Wire Part No.	EL/Z' Coil 18" Wire Part No.	Operating Voltage	Resistance at 20°C	Initial Current Draw	Power	Coil Weight
4308710	4305110	—	10 VDC	6.2 ohms	1.6 amps	15.9 watts	136 g. (4.8 oz.)
4308712	4305112	4306812	12 VDC	8.8 ohms	1.4 amps	17.2 watts	136 g. (4.8 oz.)
—	4305120	—	20 VDC	23.9 ohms	0.8 amps	15.3 watts	136 g. (4.8 oz.)
4308724	4305124	4306824	24 VDC	33.8 ohms	0.7 amps	16.6 watts	136 g. (4.8 oz.)

\* Models with Zener Diode

Note: Electrical specifications for Series E coils differ from those for standard HydraForce coils. (Refer to page 3.200.1 for standard coil specifications.)

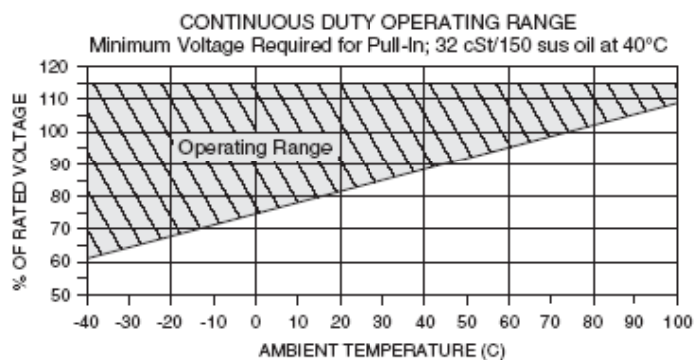



## SERIES E, ENVIROMENTAL COILS

### 08-SIZE SERIES E COILS (also for use on 98-size screw-in spool-type valves)

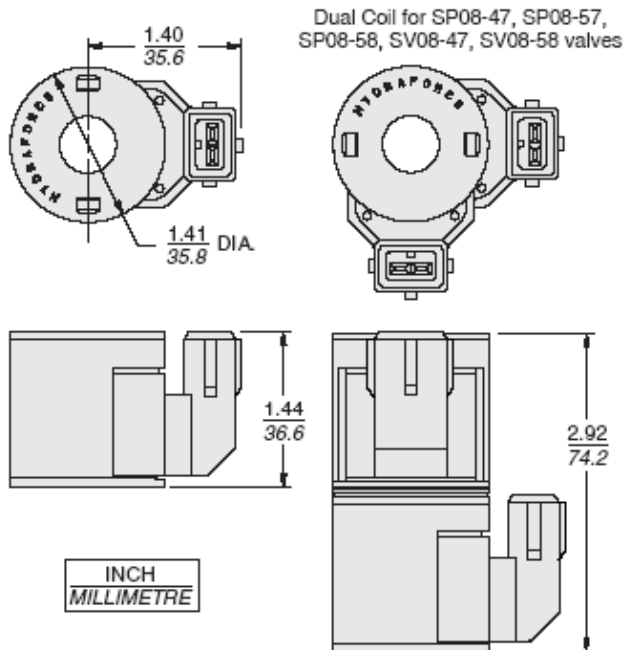

**EJ**

IP67 Rated 08-Size Coil  
Amp Jr. Timer Connector

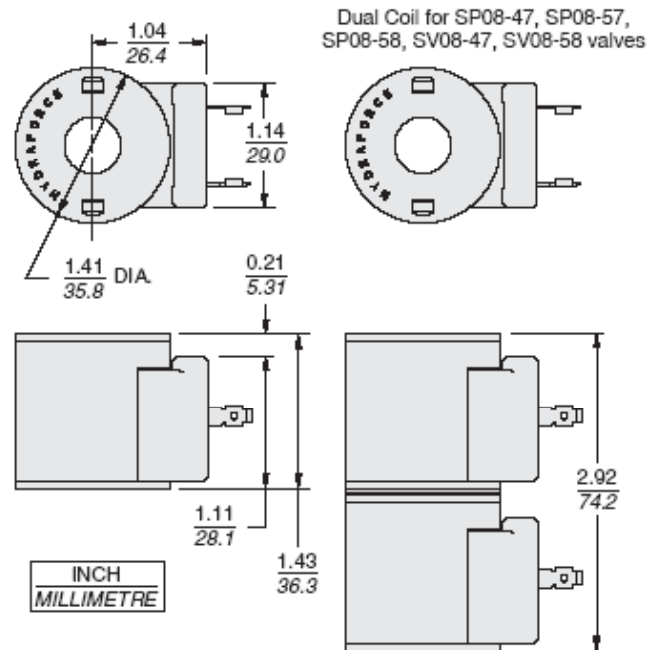

**EG**

IP65 Rated 08-Size Coil; DIN 43650 Connector  
IP67 rated if used with sealed mating connector and gasket

EJ Coil Part No.	EJ/Z* Coil Part No.	EG Coil Part No.	EG/Z* Coil Part No.	Operating Voltage	Resistance at 20°C	Initial Current Draw	Power	Coil Weight
4306112	4305912	4305862	4305872	12 VDC	8.8 ohms	1.4 amps	17.2 watts	136 g. (4.8 oz.)
4306124	4305924	4305864	4305874	24 VDC	33.8 ohms	0.7 amps	16.6 watts	136 g. (4.8 oz.)

\* Models with Zener Diode

Note: Electrical specifications for Series E coils differ from those for standard HydraForce coils. (Refer to page 3.200.1 for standard coil specifications.)

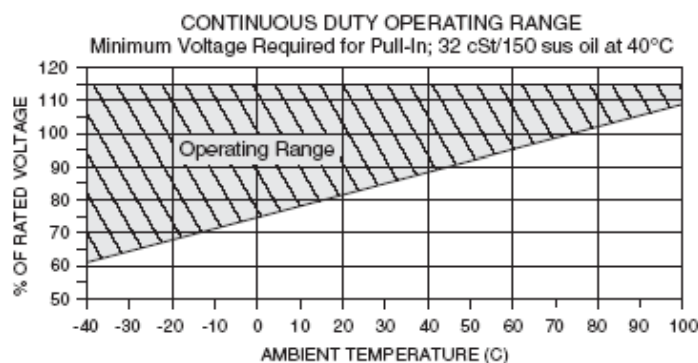

## SERIES E, ENVIROMENTAL COILS

### 10-SIZE SERIES E COILS (Also for use on 12, 16, 20, 38 and 58 size poppet valves and 90-size spool valves)

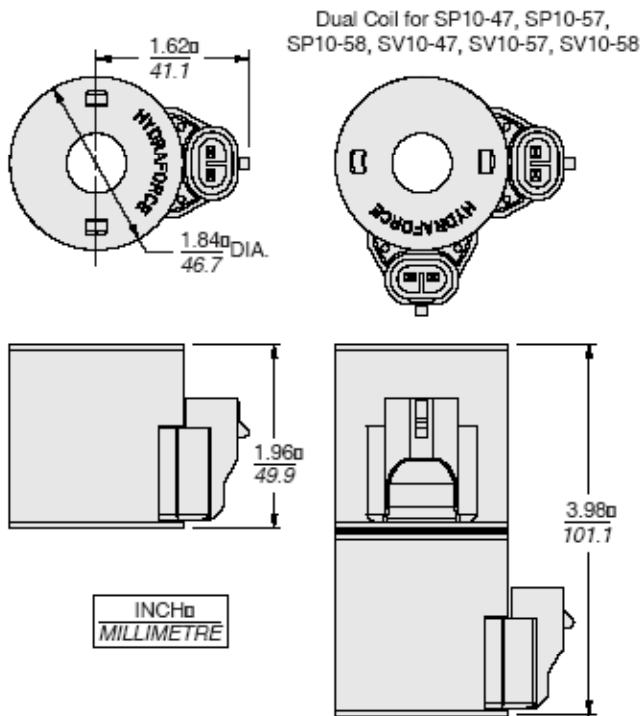

INCH  
MILLIMETRE

**EY**

**IP69K Rated 10-Size Coil**  
**Thermal Shock Dunk Test Rated Coil**  
**Metri-Pack® 150 Connector**

Mating Connector: Delphi Packard No. 12052641; HF Part No. 6110119

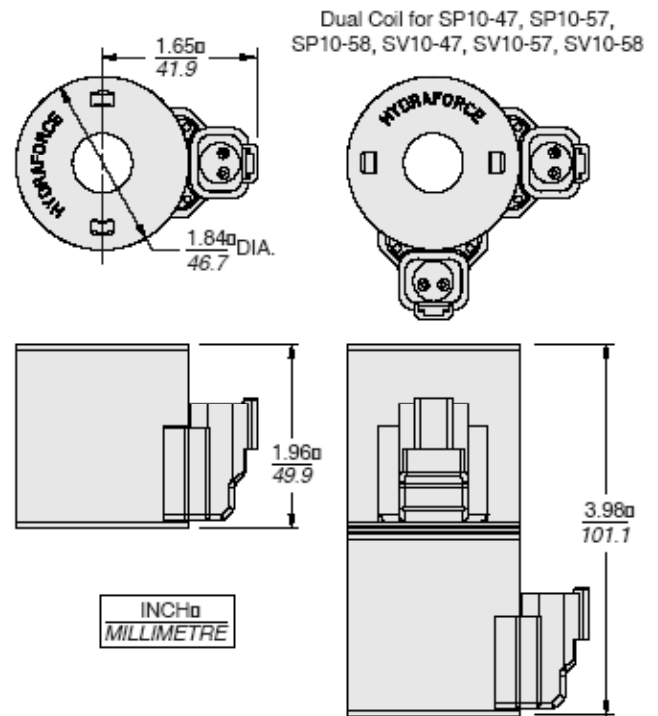

INCH  
MILLIMETRE

**ER**

**IP69K Rated 10-Size Coil**  
**Thermal Shock Dunk Test Rated Coil**  
**Deutsch DT04-2P Connector**

Mating Connector: Deutsch No. DT06-2S; HF Part No. 4001417

EY Coil Part No.	EY/Z* Coil Part No.	ER Coil Part No.	ER/Z* Coil Part No.	Operating Voltage	Resistance at 20°C	Initial Current Draw	Power	Coil Weight
4303510	4303910	4303710	4304110	10 VDC	5.0 ohms	2.0 amps	20.0 watts	408 g. (14.4 oz.)
4303512	4303912	4303712	4304112	12 VDC	7.1 ohms	1.7 amps	20.5 watts	408 g. (14.4 oz.)
4303520	—	4303720	4304120	20 VDC	19.1 ohms	1.0 amps	19.1 watts	408 g. (14.4 oz.)
4303524	4303924	4303724	4304124	24 VDC	28.5 ohms	0.8 amps	18.2 watts	408 g. (14.4 oz.)

\* Models with Zener Diode

Please note: Electrical specifications for Series E coils differ from those for standard HydraForce coils. (Refer to page 3.200.1 for standard coil specifications.)

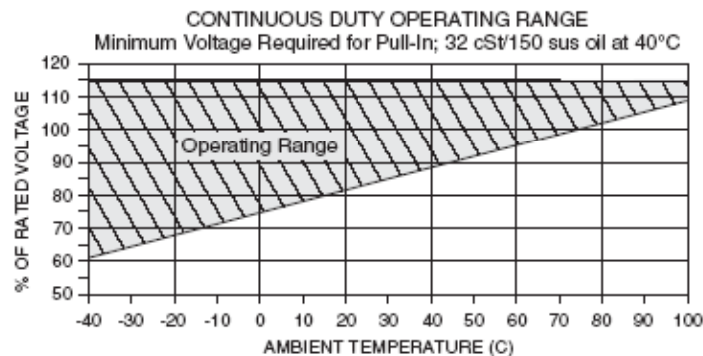

HYDRAFORCE

## SERIES E, ENVIROMENTAL COILS

### 10-SIZE SERIES E COILS (Also for use on 12-size poppet valves and 16-size poppet valves)

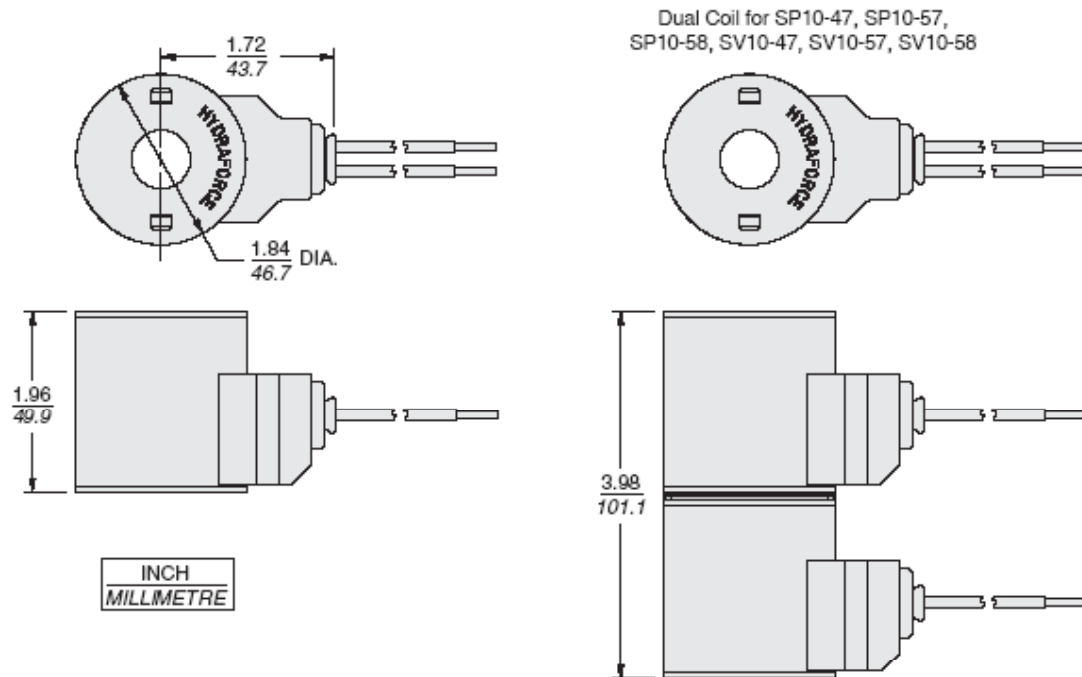

## EL

### IP69K Rated 10-Size Coil — Thermal Shock Dunk Test Rated Coil

EL Coil 36" Wire Part No.	EL Coil 18" Wire Part No.	EL/Z* Coil 18" Wire Part No.	Operating Voltage	Resistance at 20°C	Initial Current Draw	Power	Coil Weight
4317210	4305710	—	10 VDC	5.0 ohms	2.0 amps	20.0 watts	408 g. (14.4 oz.)
4317212	4305712	4307112	12 VDC	7.1 ohms	1.7 amps	20.5 watts	408 g. (14.4 oz.)
—	4305720	—	20 VDC	19.1 ohms	1.0 amps	19.1 watts	408 g. (14.4 oz.)
4317224	4305724	4307124	24 VDC	28.5 ohms	0.8 amps	18.2 watts	408 g. (14.4 oz.)

\* Models with Zener Diode

Note: Electrical specifications for Series E coils differ from those for standard HydraForce coils. (Refer to page 3.200.1 for standard coil specifications.)

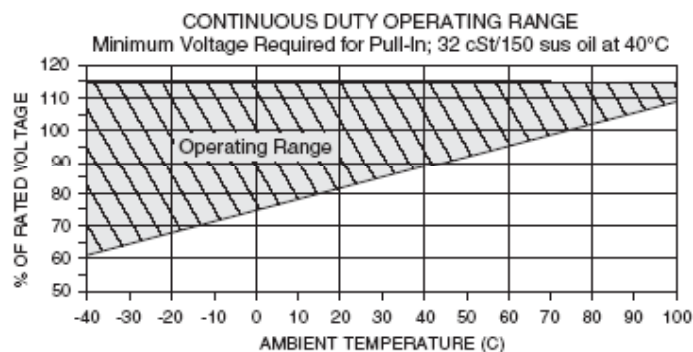

## SERIES E, ENVIROMENTAL COILS

### 10-SIZE SERIES E COILS (Also for use on 12-size poppet valves and 16-size poppet valves)

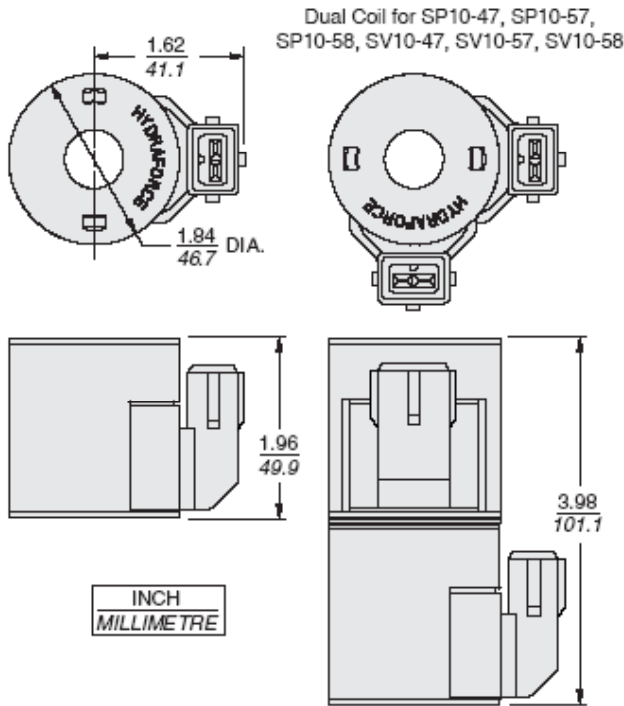

**EJ**

IP67 Rated 10-Size Coil  
Amp Jr. Timer Connector

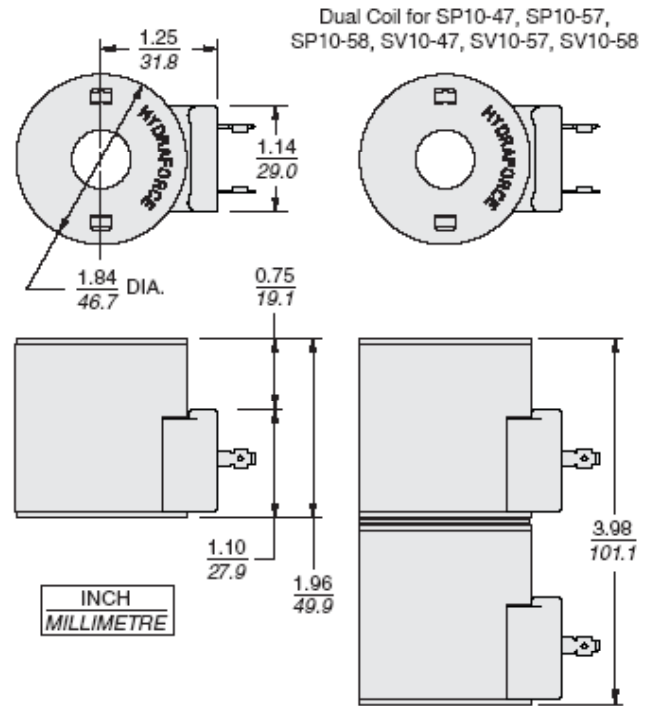

**EG**

IP65 Rated 10-Size Coil; DIN 43650 Connector  
IP67 rated if used with sealed mating connector and gasket

EJ Coil Part No.	EJ/Z* Coil Part No.	EG Coil Part No.	EG/Z* Coil Part No.	Operating Voltage	Resistance at 20°C	Initial Current Draw	Power	Coil Weight
—	—	4305881	4305891	10 VDC	5.0 ohms	2.0 amps	20.0 watts	408 g. (14.4 oz.)
4305612	4305412	4305882	4305892	12 VDC	7.1 ohms	1.7 amps	20.5 watts	408 g. (14.4 oz.)
—	—	4305883	4305893	20 VDC	19.1 ohms	1.0 amps	19.1 watts	408 g. (14.4 oz.)
4305624	4305424	4305884	4305894	24 VDC	28.5 ohms	0.8 amps	18.2 watts	408 g. (14.4 oz.)

\* Models with Zener Diode

Note: Electrical specifications for Series E coils differ from those for standard HydraForce coils. (Refer to page 3.200.1 for standard coil specifications.)

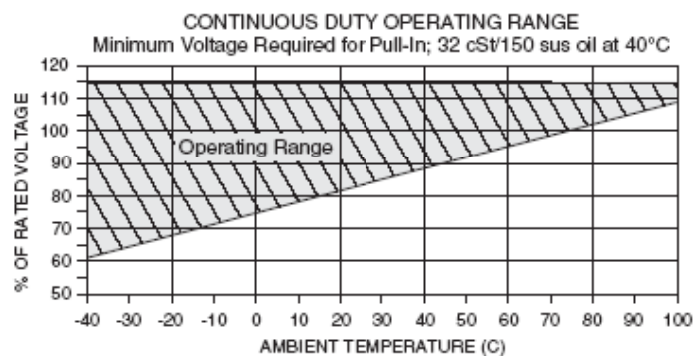

## SERIES E, ENVIROMENTAL COILS

**70-SIZE SERIES E COILS** (For use on PFR and PV valves and on 10-, 12- and 16-size valves. )

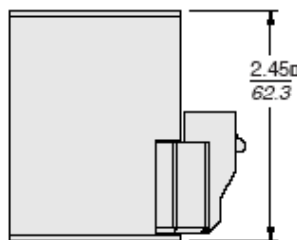
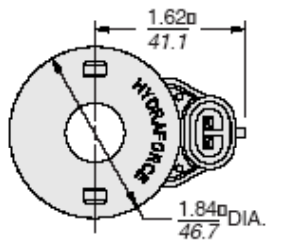

INCH  
MILLIMETRE

### EY

**IP69K Rated 70-Size Coil**  
**Thermal Shock Dunk Test Rated Coil**  
**Metri-Pack® 150 Connector**  
 Mating Connector: Delphi Packard No. 12052641  
 HF Part No. 6110119

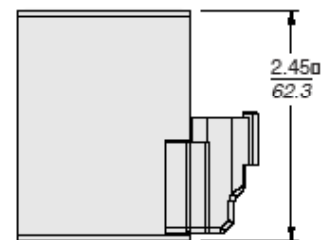
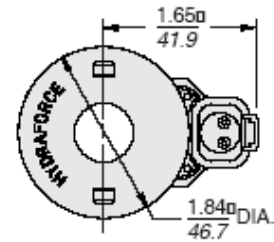

INCH  
MILLIMETRE

### ER

**IP69K Rated 70-Size Coil**  
**Thermal Shock Dunk Test Rated Coil**  
**Deutsch DT04-2P Connector**  
 Mating Connector: Deutsch No. DT06-2S  
 HF Part No. 4001417

EY Coil Part No.	ER Coil Part No.	Operating Voltage	Resistance at 20°C	Initial Current Draw	Power	Coil Weight
4303112	4303212	12 VDC	4.5 ohms	2.7 amps	32.8 watts	408 g. (14.4 oz.)
4303124	4303224	24 VDC	17.9 ohms	1.3 amps	30.3 watts	408 g. (14.4 oz.)

Note: Electrical specifications for Series E coils differ from those for standard HydraForce coils.  
 (Refer to page 3.200.1 for standard coil specifications.)

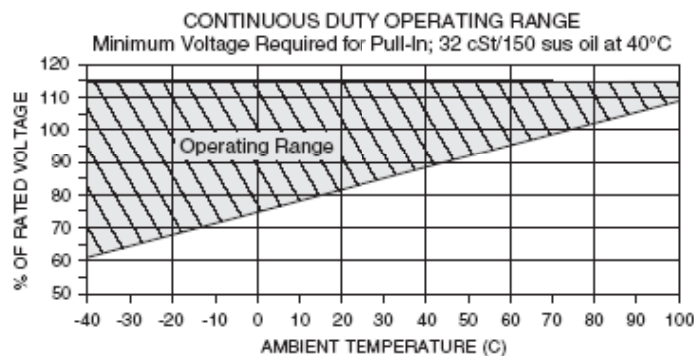

## SERIES E, ENVIROMENTAL COILS

**EHPR-SIZE SERIES E COILS** (Also for use on TS08-27, PV08 and 42-size valves.)

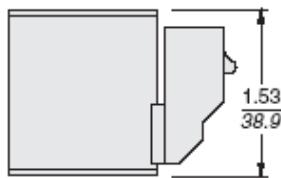
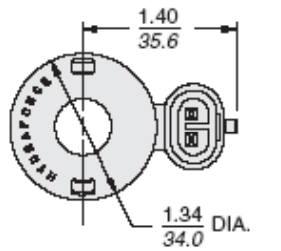

INCH  
MILLIMETRE

### EY

**IP69K Rated 08-Size Coil**  
**Thermal Shock Dunk Test Rated Coil**  
**Metri-Pack® 150 Connector**  
 Mating Connector: Delphi Packard No. 12052641  
 HF Part No. 6110119

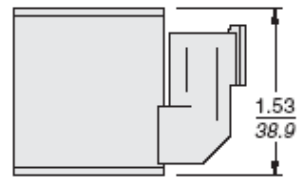
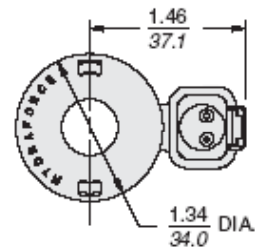

INCH  
MILLIMETRE

### ER

**IP69K Rated 08-Size Coil**  
**Thermal Shock Dunk Test Rated Coil**  
**Deutsch DT04-2P Connector**  
 Mating Connector: Deutsch No. DT06-2S  
 HF Part No. 4001417

EY Coil Part No.	ER Coil Part No.	ER/Z* Coil Part No.	Operating Voltage	Resistance at 20°C	Initial Current Draw	Power	Coil Weight
4304812	4304712	4320712	12 VDC	5.4 ohms	2.2 amps	26.1 watts	136 g. (4.8 oz.)
4304824	4304724	4320724	24 VDC	21.7 ohms	1.1 amps	26.3 watts	136 g. (4.8 oz.)

\* Models with Zener Diode

Note: Electrical specifications for Series E coils differ from those for standard HydraForce coils. (Refer to page 3.200.1 for standard coil specifications.)

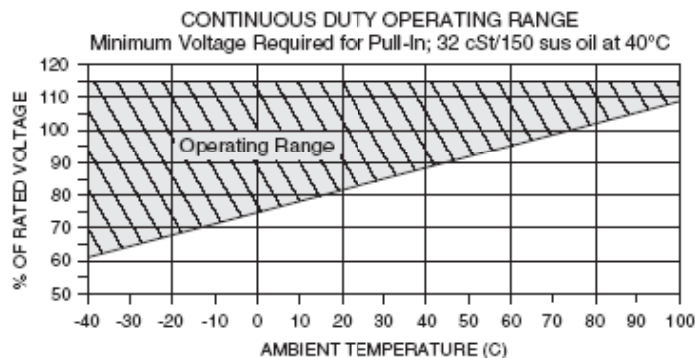



**SERIES E, ENVIROMENTAL COILS**

**12-SIZE SERIES E COILS (For 12 Size Spool Valves Only)**

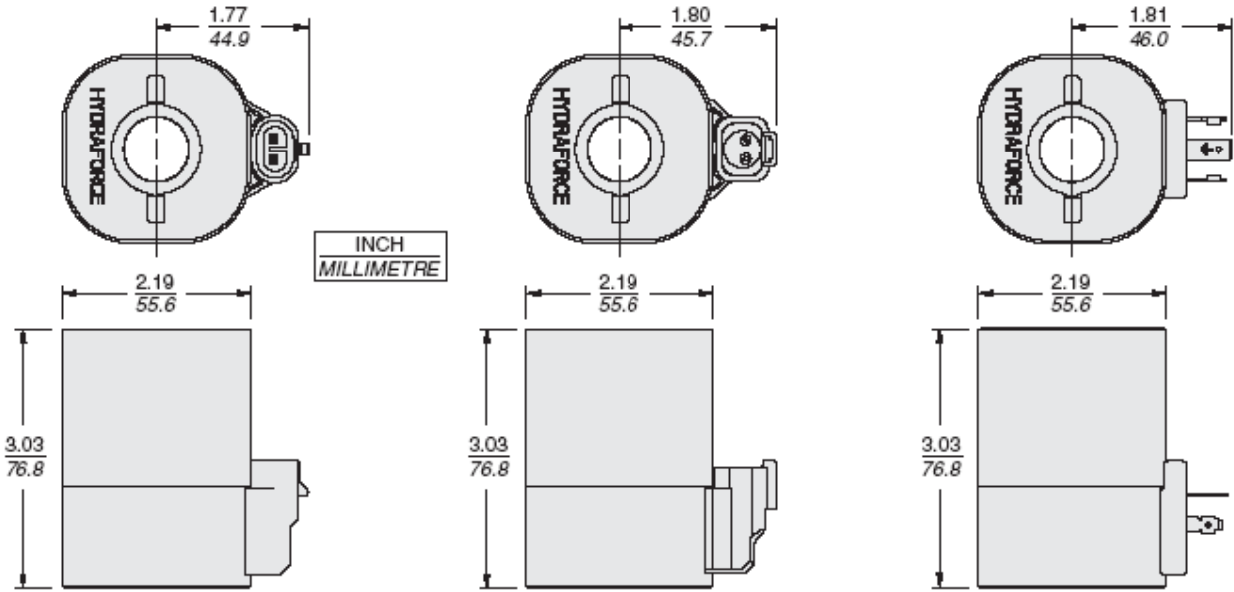

**EY**

**IP69K Rated 12-Size Coil**  
**Thermal Shock Dunk Test Rated**  
**Metri-Pack® 150 Connector**  
 Mating Connector:  
 Delphi Packard No. 12052641  
 HF Part No. 6110119

**ER**

**IP69K Rated 12-Size Coil**  
**Thermal Shock Dunk Test Rated**  
**Deutsch DT04-2P Connector**  
 Mating Connector:  
 Deutsch No. DT06-2S — HF Part No. 4001417

**EG**

**IP65 Rated 12-Size Coil**  
**DIN 43650 Connector**  
 Can be IP67 rated if used with  
 sealed mating connector  
 and gasket

EY Coil Part No.	EY/Z* Coil Part No.	ER Coil Part No.	ER/Z* Coil Part No.	EG Coil Part No.	Operating Voltage	Resistance at 20°C	Initial Current Draw	Power	Coil Weight
6964012	4302206	4301212	4305512	6956012	12 VDC	4.6 ohms	2.6 amps	31.1 watts	1 kg. (2.2 lbs.)
6964024	4302207	4301224	4305524	6956024	24 VDC	18.3 ohms	1.3 amps	31.0 watts	1 kg. (2.2 lbs.)

\* Models with Zener Diode

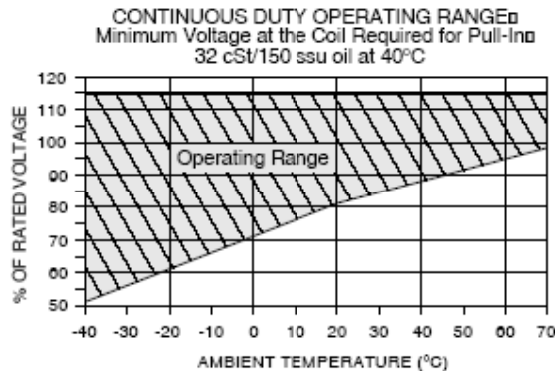

## SERIES E, ENVIROMENTAL COILS

### 12-SIZE SERIES E COILS (For 12 Size Spool Valves Only)

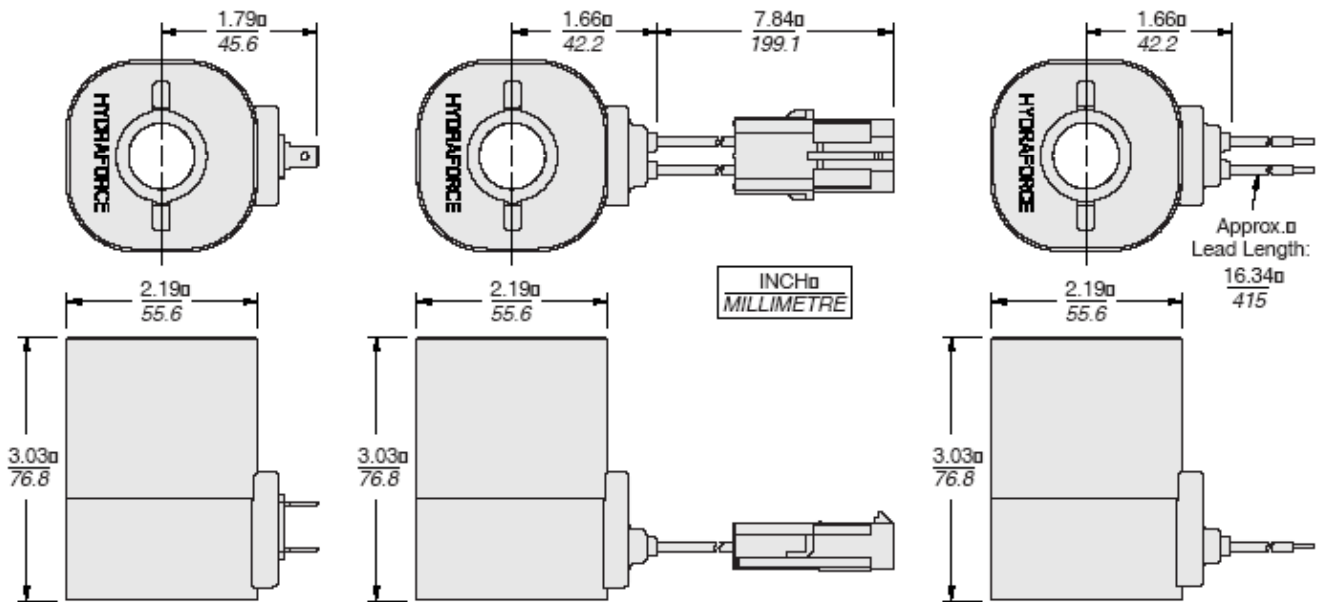

### ES

IP65 Rated 12-Size Coil  
Dual Spades SAE J858a

### EW

IP65 Rated 12-Size Coil  
Dual 18 Gauge Leads  
with Weather-Pack® Connector  
Mating Connector: Delphi Packard No. 12015792

### EL

IP65 Rated 12-Size Coil  
Dual Leads – 18 Gauge

ES Coil Part No.	EW Coil Part No.	EL Coil Part No.	Operating Voltage	Resistance at 20°C	Initial Current Draw	Power	Coil Weight
—	—	6852010	10 VDC	3.2 ohms	3.1 amps	31.2 watts	1 kg. (2.2 lbs.)
6851012	6853012	6852012	12 VDC	4.6 ohms	2.6 amps	31.1 watts	1 kg. (2.2 lbs.)
6851024	6853024	6852024	24 VDC	18.3 ohms	1.3 amps	31.0 watts	1 kg. (2.2 lbs.)

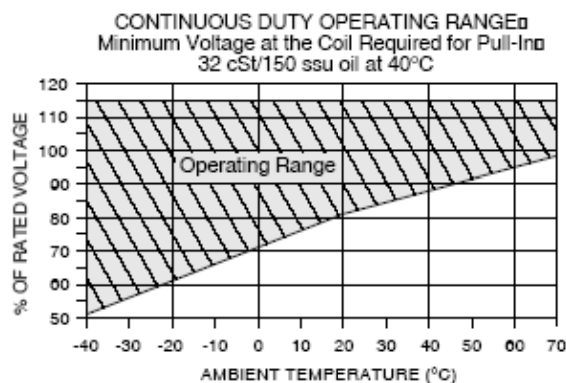





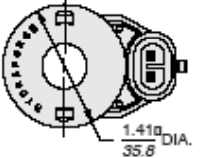
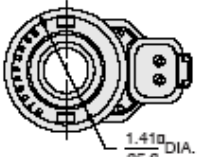
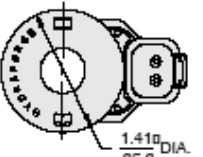

## SERIES E, ENVIROMENTAL COILS

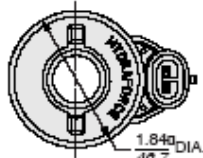
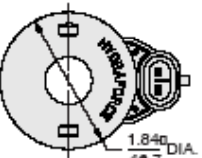
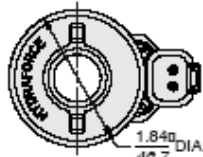
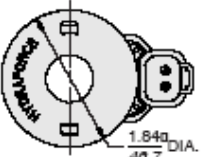



### SERIES E COILS PART NUMBER CROSS REFERENCE

08-Size E-Coils	Original Design Manuf. before 1-1-04	New Design Manuf. after 1-1-04
Code EY Metri-Pack® 150 Connector Top view shown w/o retaining nut		
10 VDC	4300110	4303410
12 VDC	4300112	4303412
20 VDC	—	4303420
24 VDC	4300124	4303424
Code ER Deutsch DT04-2P Connector Top view shown w/o retaining nut		
10 VDC	4300310	4303610
12 VDC	4300312	4303612
20 VDC	—	4303620
24 VDC	4300324	4303624

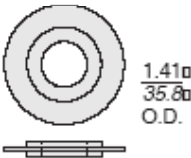
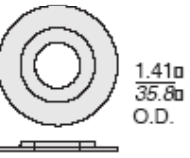
10-Size E-Coils	Original Design Manuf. before 1-1-04	New Design Manuf. after 1-1-04
Code EY Metri-Pack® 150 Connector Top view shown w/o retaining nut		
10 VDC	4300210	4303510
12 VDC	4300212	4303512
20 VDC	—	4303520
24 VDC	4300224	4303524
Code ER Deutsch DT04-2P Connector Top view shown w/o retaining nut		
10 VDC	4300410	4303710
12 VDC	4300412	4303712
20 VDC	—	4303720
24 VDC	4300424	4303724





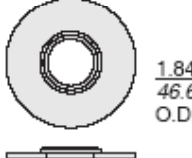
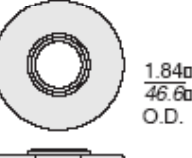









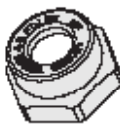

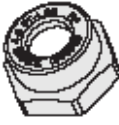

### SERIES E COIL NUT & SPACER CROSS REF. FOR SPxx-47 & SVxx-47 DUAL SOLENOID VALVES

For SP08-47 & SV08-47 Series Valves	Retaining Nut and Spacer for Original E-Coil Design Manuf. before 1-1-04	Retaining Nut and Spacer for New E-Coil Design Manuf. after 1-1-04
Retaining Nut for SP08-47's & SV08-47's without Manual Override Part Number:	 Nut: 4502960	 Nut: 7004400
Retaining Nut for SP08-47M's & SV08-47M's with Manual Override Part Number:	 Nut: 4528150	 Nut: 4528180
Coil Spacer for all SP08-47 & SV08-47 Series Valves (installs between the two coils) Part Number:	 Spacer: 4514810	 Spacer: 4534720

For SP10-47 & SV10-47 Series Valve	Retaining Nut and Spacer for Original E-Coil Design Manuf. before 1-1-04	Retaining Nut and Spacer for New E-Coil Design Manuf. after 1-1-04
Retaining Nut for SP10-47's & SV10-47's without Manual Override Part Number:	 Nut: 4502960	 Nut: 7004400
Retaining Nut for SP10-47M's & SV10-47M's with Manual Override Part Number:	 Nut: 4527160	 Nut: 4527540
Coil Spacer for all SP10-47 & SV10-47 Series Valves (installs between the two coils) Part Number:	 Spacer: 4514130	 Spacer: 4539700

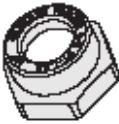
## SERIES E, ENVIROMENTAL COILS

### SERIES E COIL NUT CROSS REFERENCE

Valve Models	Retaining Nuts for Original E-Coil Design	Retaining Nuts for New E-Coil Design	Valve Models	Retaining Nuts for Original E-Coil Design	Retaining Nuts for New E-Coil Design
	Manufactured before 1-1-04	Manufactured after 1-1-04		Manufactured before 1-1-04	Manufactured after 1-1-04
SF08-20 SV08-33 SP08-20 SV08-40 SV08-20 SV08-41 SV08-22 SV08-42 SV08-24 SV08-43 SV08-25 SV08-44 SV08-26 SV08-45 SV08-31 SV08-46	 Nut: 4502960	 Nut: 7004400	SF10-20M/J/Y SV10-22M/J/Y SV10-24M/J/Y SV10-25M/J/Y SV10-30M/J/Y SV10-31M/J/Y SV10-33M/J/Y SV10-34M/J/Y SV10-40M/J/Y SV10-41M/J/Y SV10-42M/J/Y SV10-43M/J/Y SV10-44M/J/Y SV10-45M/J/Y SV38-20M/J/Y SV58-xxM/J/Y	 Nut: 4626260-2	 Nut: 7004590
SF08-20M/J/Y SV08-20M/J/Y SV08-22M/J/Y SV08-24M/J/Y SV08-25M/J/Y SV08-26M/J/Y SV08-31M/J/Y SV08-33M/J/Y SV08-40M/J/Y SV08-41M/J/Y SV08-42M/J/Y SV08-43M/J/Y SV08-44M/J/Y SV08-45M/J/Y SV08-46M/J/Y	 Nut: 4626260-1	 Nut: 7004490	SP10-24 SV10-21 SV10-21P/K SV10-23 SV10-23P/K SV38-38 SV38-38P/K	 Nut: 4503610	 Nut: 7004420
SF08-21 SV08-21 SV08-21P/K SV08-23 SV08-23P/K	 Nut: 4514800	 Nut: 7004410	TS08-20 TS80-30 TS98-30 TS98-31	 Nut: 4514800	 Nut: 7004410
SP10-20 SV10-40 SP10-41 SV10-41 SP10-46R SV10-42 SP12-20 SV10-43 SV10-20 SV10-44 SV10-22 SV10-45 SV10-24 SV12-20 SV10-25 SV12-22 SV10-30 SV16-20 SV10-31 SV16-22 SV10-33 SV38-20 SV10-34 SV58-xx	 Nut: 4502960	 Nut: 7004400	TS10-26 TS10-36 TS12-26 TS12-36 TS38-20	 Nut: 4526330	 Nut: 4540560
			TS10-27 TS12-27 TS38-21	 Nut: 4519810	 Nut: 4540550