



PM PUMPS



PMV0. VARIABLE DISPLACEMENT PUMPS

OVERVIEW

PMV0 is a variable displacement, axial piston pump, with swashplate system, for closed loop hydrostatic transmissions.

It provides a continuously variable flow rate between zero and maximum in forward and reverse direction. Flow rate is proportional to rotation speed and swashplate angle.

It can feature a charge pump to keep the circuit pressurised. This avoids risk of cavitations and ensures a good performance of the transmission.

It offers two types of control: direct mechanical and servo hydraulic.

It is equipped with high pressure relief valves and can be delivered with auxiliary gear pumps.

It is available in single or tandem versions.

As options, PMV0 can be featured with flushing valve, filter on charge pressure line and safety devices to ensure safe operation of the machine.

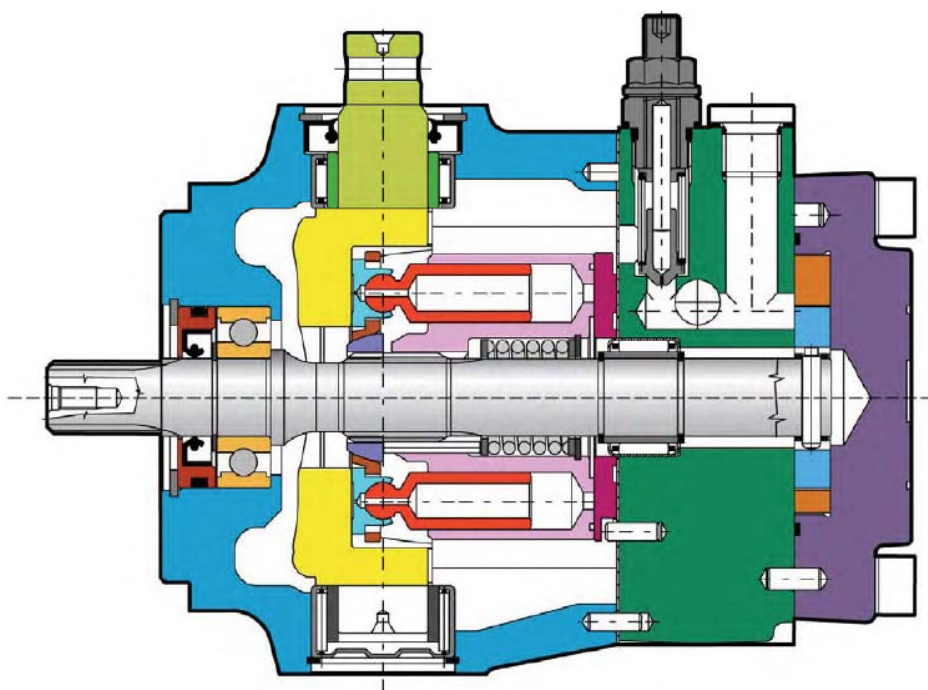

		PMV0-07	PMV0-09	PMV0-11	PMV0-14	PMV0-18
Displacement	cm ³ /rev [in ³ /rev.]	7,08 [0.43]	9,08 [0.55]	11,83 [0.72]	14,32 [0.87]	17,85 [1.09]
Theoretical Flow at rated speed	l/min [GPM]	25,5 [6.74]	32,7 [8.64]	42,6 [11.25]	51,6 [13.63]	64,3 [16.99]
Rated speed	rpm	3 600				
Rated pressure	bar [PSI]	210 [3 045]				
Max. Pressure	bar [PSI]	300 [4 351]				
Mounting flange		SAE A				
Controls		Direct mechanical and servo hydraulic				
Mass	kg [lb]	From 7,5 [16.5] to 9,5 [20.9]				
Rotation		Clockwise or Counterclockwise				



CONTENT

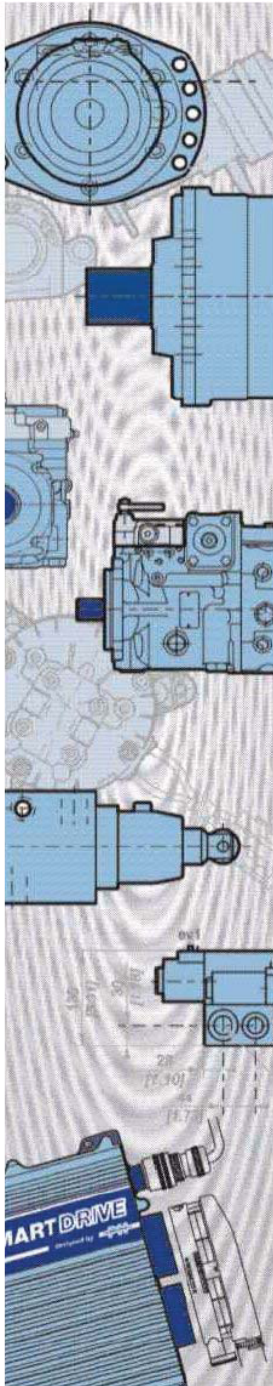

MODEL CODE	4	→	Model Code
TECHNICAL SPECIFICATIONS	6		Technical specifications
Features	6		
Performances	6		
Main dimensions	7		
Port characteristics	7		
OPERATING PARAMETERS	9		Operating Parameters
Operating parameters	9		
Charge pressure	9		
Case pressure	9		
Pressure ratings	9		
Speed ratings	9		
Inlet pressure	10		
Theoretical output	10		
Poclair Hydraulics recommendations for fluid	10		
Fluid and filtration	11		
Viscosity range	11		
SYSTEM DESIGN PARAMETERS	12		System design Parameters
Sizing equations	12		
Redundant braking system requirement	12		
Loop flushing	12		
Reservoir	13		
Case drain usage for tandem pump	13		
Differential pressure	13		
Bearing life and external shaft loading	14		
Hydraulic unit life	15		
Mounting flange loads	15		
FEATURES	16		Features
High pressure relief valve	16		
Charge relief valve	17		
Charge pump	18		
Displacement limiters	19		
By-pass	19		
Mounting flange and shafts	20		
Auxiliary mounting pad	22		
Tandem pumps	24		
Gear pumps	25		
CONTROLS	26		Controls
Direct mechanical control	26		
Direct mechanical control with return spring	28		
Hydraulic servo control	30		
OPTIONS	33		Options
Screw by-pass	33		
Lever by-pass	34		
Electrical by-pass with brake engaged	35		
Roller bearing	36		
Fluorinated elastomer seals	36		
UNF threads ports	36		
Low noise valve plate	36		
Filter on suction line	37		
Filter on pressure line	38		
Swashplate on bushing	39		
Flushing valve	39		
Pressure gauge ports on relief valve	39		

MODEL

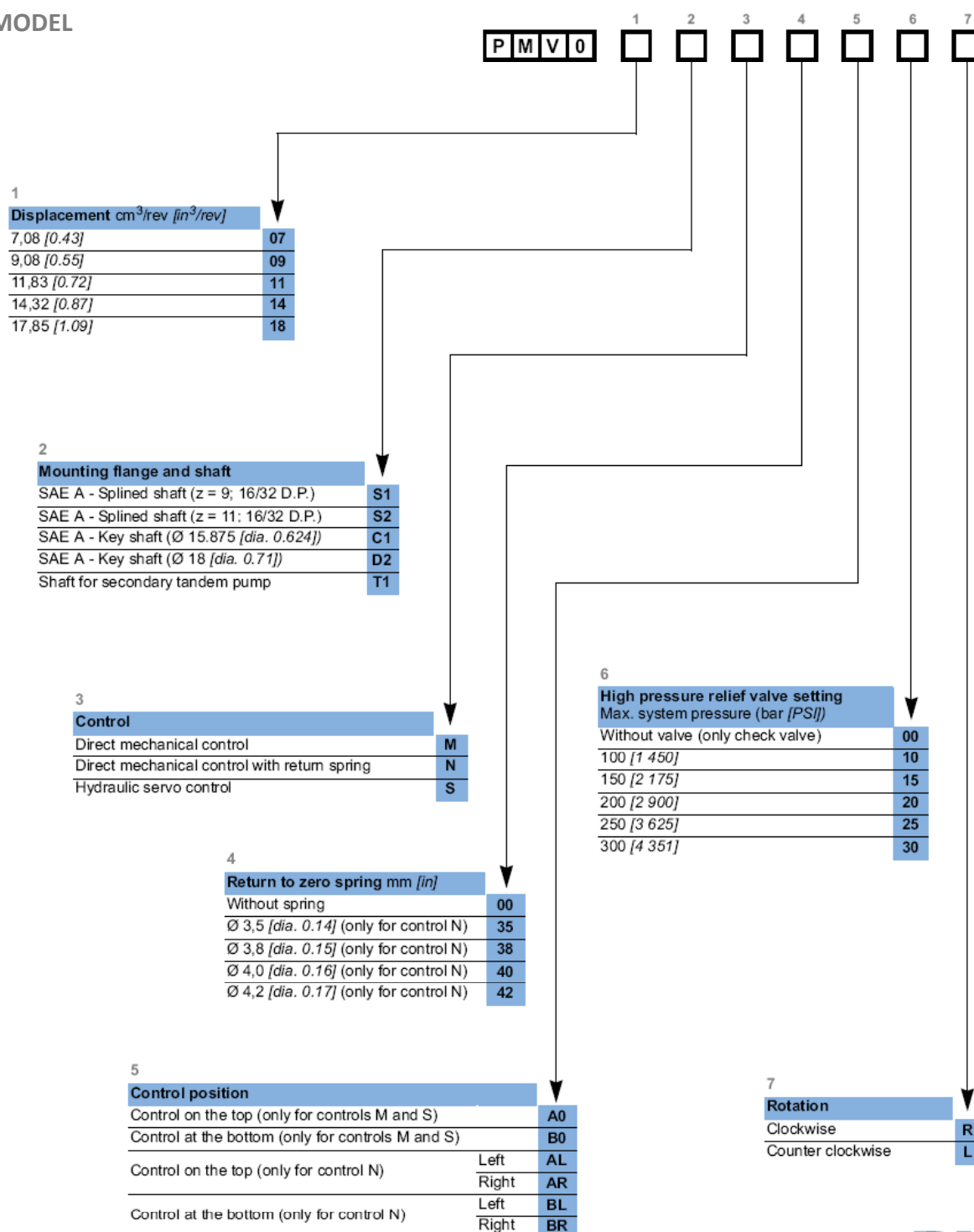

CODE



8		
Charge relief valve setting bar [PSI]		
Without	(Only for front pump on tandem)	00
10 [145]	(Only for controls M and N; standard setting)	10
20 [290]	(For all controls)	20

9		
Charge pump displacement cm^3/rev [in^3/rev]		
Without charge pump		00
4,9 [0.30]		05

10		
Auxiliary mounting pad		
Without auxiliary mounting pad		S
German group 1		F
German group 2		G
Tandem fitting		T

11		
Gear pump cm^3/rev [$\text{cu.in}/\text{rev}$]		
Without gear pump		00
	1,6 [0.10]	01
	2,0 [0.12]	02
German group 1	3,2 [0.19]	03
(if digit 10 = F)	4,2 [0.26]	04
	5,0 [0.30]	05
	6,3 [0.38]	06
	4,0 [0.24]	04
	6,0 [0.37]	06
	8,5 [0.52]	08
German group 2	11,0 [0.67]	11
(if digit 10 = G)	14,0 [0.85]	14
	16,5 [1.01]	17
	19,5 [1.19]	20

12		
Options		
Without option		00
Electrical by-pass with brake engaged (12V)		BF12
Electrical by-pass with brake engaged (24V)		BF24
Screw by-pass in the cover (only for axial pump without charge pump)		BH
Lever by-pass		BL
Roller bearing (Only with S1 or C1 shaft)		CR
Low noise valve plate		DB
Fluorinated elastomer seals		EV
Filter on suction line		FA
Filter on pressure line without clogging indicator		F0
Filter on pressure line with clogging indicator		F2
UNF Threads ports		FU
Swashplate on bushing		OB
Pressure gauge ports on relief valve		PP
Flushing valve		VS



it is possible to combine several options. Consult your Poclair Hydraulics application engineer for more information.

TECHNICAL SPECIFICATIONS

Features

		PMV0-07	PMV0-09	PMV0-11	PMV0-14	PMV0-18
Displacement	cm ³ /rev [in ³ /rev.]	7,08 [0.43]	9,08 [0.55]	11,83 [0.72]	14,32 [0.87]	17,85 [1.09]
Theoretical flow at rated speed (3600 rpm)	L/min [GPM]	25,5 [6.74]	32,7 [8.64]	42,6 [11.25]	51,6 [13.63]	64,3 [16.99]
Max. Theoretical absorbed power	KW	12,7	16,3	21,3	25,8	30,5
Theoretical absorbed torque at 100 bar [1 450 PSI]	N.m [in.lbf]	11,3 [100]	14,5 [128]	18,8 [166]	22,8 [202]	28,4 [251]
Moment of inertia	kg.m ² [slug.ft ²]			0,0014 [0.0010]		
Internal charge pump	cm ³ /rev [in ³ /rev]			4,9 [0.30]		
Charge relief valve setting	bar [PSI]			From 6 [87] to 30 [435]		
High pressure relief setting	bar [PSI]			Max. 300 [4 351]		
Mounting flange				SAE A		
Mass	kg [lb]			7,5 [16.5] with control M 9,5 [20.9] with control S		

Performances

Efficiency at the max. pump displacement

Oil ISO VG46, temperature = 50°C [122°F].

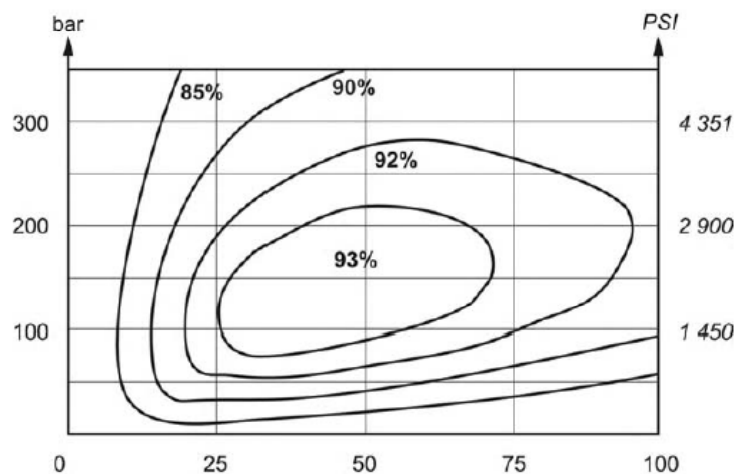

Main dimensions

PMV0 with direct mechanical control and without auxiliary mounting pad

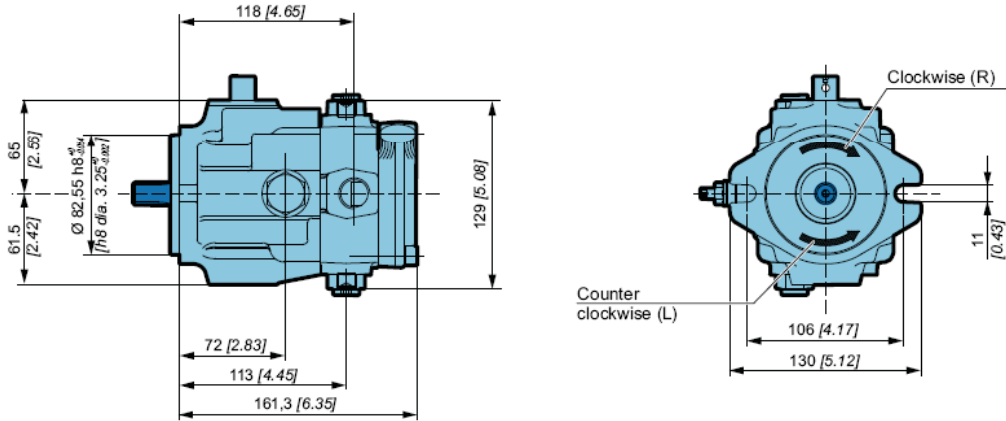

See from page 26 to page 31 for control dimensions.

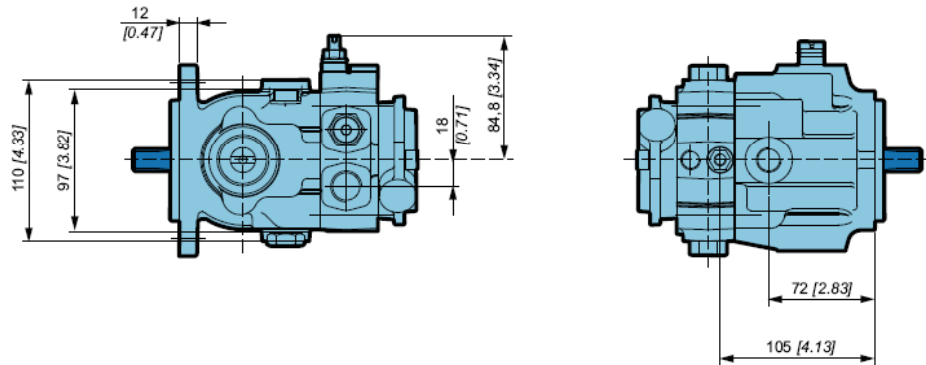

Port characteristics

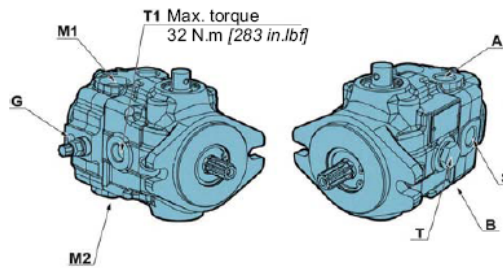

T1 Max. torque
32 N.m [283 in.lbf]

Port	Function	ISO 1179-1 (standard)	ISO 11926-1 (option FU)
A-B	Services	1/2" GAS	3/4-16 UNF-2B
G	Auxiliary	1/4" GAS	7/16-20 UNF-2B
M1/M2	Gauge	1/8" GAS	-
S	Suction	1/2" GAS	3/4-16 UNF-2B
T/T1	Drain	3/8" GAS	3/4-16 UNF-2B



OPERATING PARAMETERS

Operating parameters

		PMV0-07	PMV0-09	PMV0-11	PMV0-14	PMV0-18
Speed ratings	Minimum			700		
	Max. without load	rpm		3 900		
	Max. with load			3 600		
System pressure	Rated			210 [3 045]		
	Maximum	bar [PSI]		300 [4 351]		
	Minimum low loop			6 [87]		
Inlet pressure	Mini continuous	bar abs. [PSI abs.]		0,8 [11.6]		
	Mini (cold start)			0,5 [7.2]		
Case pressure	Continuous	bar [PSI]		1,5 [21.7]		
	Maximum (cold start)			2,5 [36.2]		
Charge pressure	Standard version	bar [PSI]		20 [290]		
	Max. charge pressure			30 [435]		

Charge pressure

A charge flow is required to maintain a positive pressure in the low pressure loop of a closed loop hydrostatic transmission. Charge pressure ensures proper lubrication and rotating group operation. It is recommended to maintain the charge pressure at a minimum of 6 bar [87 psi] above case pressure. In case of direct mechanical control (M), charge pressure must be set at 10 bar [145 PSI] mini. In case of servo control (S), charge pressure must be set at 20 bar [290 PSI]. For more details, refer to charge pump paragraph, page 18.

Case pressure

Case pressure must be maintained within the limits shown in the table "Operating parameters". Ensure housing is always filled with hydraulic fluid and especially during start-up of the machine.

Pressure ratings

Maximum peak pressure

It is the maximum allowable pressure. It is equivalent to the maximum setting of the maximum high pressure relief valve. A self-propelled machine can reach the maximum peak pressure value no more than 1-2% of that work cycle.

Work cycle

A fundamental factor for ensuring correct hydrostatic transmission sizing is the machine work cycle (pressure-time ratio, seasonality, pressure vs. percentage of time at max. displacement, machine type). Part service life depends on the correct choice in relation to the work cycle.

Overloads

It is mandatory to protect parts against any possible overloads.

Speed ratings

The table "Operating parameters" gives minimum and maximum rated speeds. Note that all displacements might operate under different speed limits. Definitions of these speed limits appear below.

Maximum speed is the highest operating speed allowed. Over speeding reduces pump life time, can lead to loss of hydrostatic power and braking capacity. Never exceed the maximum speed limit under any operating conditions.

Nominal speed is the speed offering the maximal efficiency.



Inlet pressure

Charge pump inlet pressure is key for acceptable pump life and performances. A continuous inlet pressure of not less than 0,8 bar abs. [11.6 PSI abs.] is recommended. An continuous inlet pressure less than 0.5 bar abs. [7.2 PSI abs.] indicates inadequate inlet design or a restricted filter. Pressures less than 0.5 bar abs. [7.2 PSI abs.] can happen at cold start, but should increase with oil temperature.

Theoretical output

Theoretical output flow is a function of pump displacement and speed. It is relevant to size the rest of the circuit. Theoretical flow does not take into account losses due to leakage or variations in displacement. Refer to performances, page 6, for volumetric and overall efficiencies at various operating speeds and pressures.

Poclair Hydraulics recommendations for fluid



Poclair hydraulics recommends the use of hydraulic fluids defined by the ISO 12380 and ISO 6743-4 standards. For temperate climates, the following types are recommended.

- HM 46 or HM 68 for fixed installations.
- HV 46 or HV 68 for mobile installations.
- HEES 46 for mobile installations.

These specifications correspond to category 91H of the CETOP standard, parts 1, 2 and 3 of the DIN 51524 standard, and grades VG32, VG 46 and VG68 of the ISO 6743-4 standards.



It is also possible to use ATF, HD, HFB, HFC or HFD type hydraulic fluid upon Poclair Hydraulics specific approval of the components' operating conditions.

Standardized designations for the fluids

- **HM** : Mineral fluids having specific antioxidant, anticorrosion and antiwear properties (HLP equivalent to DIN 51524 parts 1 and 2).
- **HV** : HM mineral fluids providing improved temperature and viscosity properties (DIN 51524 part 3).
- **HEES** : Biodegradable fluids based on organic esters.



It is also possible to use a fluid that meets the biodegradability criteria and is compatible in the event of accidental food contact. The BIOHYDRAN FG 46 fluid designed by the company Total has undergone testing of its properties and performance on our test benches. Since this type of fluid has not yet been categorized, it is the responsibility of machine manufacturers to validate its compatibility with all of the components used in order to guarantee that the intended functions will be fulfilled and this for the desired life time of all equipment items.



For biodegradable fluids, consult your Poclair Hydraulics' application engineer



During operation, the temperature of the oil must be between 0°C [32°F] and 80°C [176°F]; the minimum and maximum temperatures may be exceeded momentarily by ± 20°C [± 68°F] for a duration of less than 30 minutes. For all applications outside these limits, please consult with your Poclair Hydraulics' application engineer.

Fluid and filtration

The contaminating particles suspended in the hydraulic fluid cause the hydraulic mechanisms moving part wear. On hydraulic pumps, these parts operate with very small dimensional tolerances. In order to reach the part life, it is recommended to use a filter that maintains the hydraulic fluid contamination class at a max. of:

9 according to NAS 1638
20/18/15 according to ISO 4406:1999

According to the type of application decided for the pump, it is necessary to use filtration elements with a filtration ratio of:

β 20 to 30 \geq 100

Making sure that this ratio does not worsen together with the increasing of the filter cartridge differential pressure.

If these values cannot be observed, the component life will consequently be reduced and it is recommended to contact the Poclain Hydraulics Customer Service.

Filters on charge circuit

Filters on the charge circuit (F0-F2) are designed without by-pass. The max. pressure drop on the filtration part must not exceed 2 bar [29 PSI] (3 bar [43.5 PSI] in case of cold starting) at pump full rating. To monitor the pressure drop, it is recommended to use the clogging indicator on the filtration element (F2 option). Contact your Poclain Hydraulics Application engineer, each time the pump is not charged by its internal charge pump.

Filters on charge circuit are mounted on the pump special support.

Filters assembling

The suction filter is mounted on the suction line. Check that the pressure before the charge pump is 0.8 bar abs. [11.6 PSI abs.], measured on the pump suction port (0.5 bar [7.2 PSI] for cold starting).

Viscosity range

For both max. efficiency and life of the unit, the operative viscosity should be chosen within the optimum range of:

ν_{opt} = optimum operating viscosity from 16 to 36 mm²/s [from 74.1 to 166.8 SUS] referred to the closed loop temperature.

Working conditions: the following limits of viscosity apply

ν_{min} = 5 mm²/s [23 SUS] short-duration at a max. permissible leakage oil temperature of 90° C [194°F]

ν_{max} = 1000 mm²/s [4 634 SUS] short-duration, on cold start.

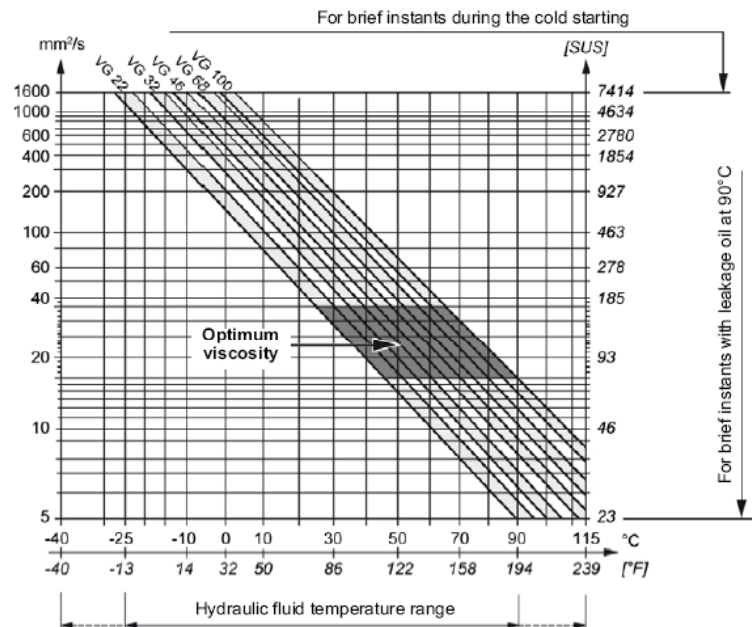

Ensure fluid temperature and viscosity limits are concurrently satisfied.



SYSTEM DESIGN PARAMETERS



Consult your Poclain Hydraulics application engineer to validate your design parameters before using the pump in your application.

Sizing equations

The following equations are helpful when sizing hydraulic pumps. Generally, the sizing process is initiated by an evaluation of the machine system to determine the required motor speed and torque to perform the necessary work function. First, the motor is sized to transmit the maximum required torque. The pump is then selected as a flow source to achieve the maximum motor speed.

	Output flow Q	=	$\frac{V_g \cdot n \cdot \eta_v}{1000}$	(l/min)	
SI units	Input torque M	=	$\frac{V_g \cdot \Delta p}{20 \cdot \pi \cdot \eta_m}$	(N.m)	
	Input power P	=	$\frac{M \cdot n \cdot \pi}{30\,000} = \frac{Q \cdot \Delta p}{600 \cdot \eta_t}$	(kW)	
	Output flow Q	=	$\frac{V_g \cdot n \cdot \eta_v}{231}$	[GPM]	
US units	Input torque M	=	$\frac{V_g \cdot \Delta p}{2 \cdot \pi \cdot \eta_m}$	[lbf.in]	
	Input power P	=	$\frac{M \cdot n \cdot \pi}{198\,000} = \frac{Q \cdot \Delta p}{1714 \cdot \eta_t}$	[hp]	

V_g = Displacement per revolution cm^3/tr [in^3/rev]
 Δp = $p_o - p_i$ (system pressure) bar [PSI]
 n = Speed min^{-1} [rpm]
 η_v = Volumetric efficiency
 η_m = Mechanical efficiency
 η_t = Overall efficiency = $\eta_v \times \eta_m$

Redundant braking system requirement



Unintended vehicle or machine movement hazard.

The loss of hydrostatic drive line power, in any mode of operation (forward, neutral, or reverse) may cause the system to lose hydrostatic braking capacity. You must provide a braking system, redundant to the hydrostatic transmission, sufficient to stop and hold the vehicle or machine in the event of hydrostatic drive power loss.

Loop flushing

Closed circuit may require a flushing valve to meet temperature and cleanliness requirements. A flushing valve takes a part of hot fluid flow from the low pressure loop of the system loop for cooling and filtering. Make sure that the charge pump provides adequate flow for the flushing valve and the flushing valve does not cause charge pressure to drop below recommended limits.

See option VS page 39 for more information

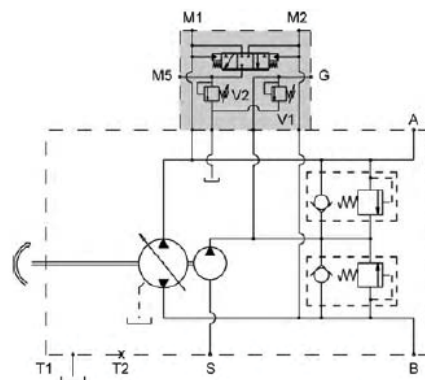

Reservoir

The reservoir provides clean fluid, dissipates heat, and removes entrained air from the hydraulic fluid. It allows for fluid volume changes associated with fluid expansion and cylinder differential volumes. Minimum reservoir capacity depends on the volume needed to perform these functions. Typically, a capacity of one half the charge pump flow (per minute) is satisfactory for a closed reservoir. Open circuit systems sharing a common reservoir require greater fluid capacity.

Locate the reservoir outlet (suction line) near the bottom, allowing clearance for settling foreign particles. Use a 100 - 125 μm screen covering the outlet port.

Place the reservoir inlet (return lines) below the lowest expected fluid level, as far away from the outlet as possible.

Use a baffle (or baffles) between the reservoir inlet and outlet ports to promote de-aeration and reduce fluid surging.

Case drain usage for tandem pump

On tandem pumps, and to ensure lubrication of both pumps, excess flow from the first pump charge relief valve must be routed into the housing of the second pump.

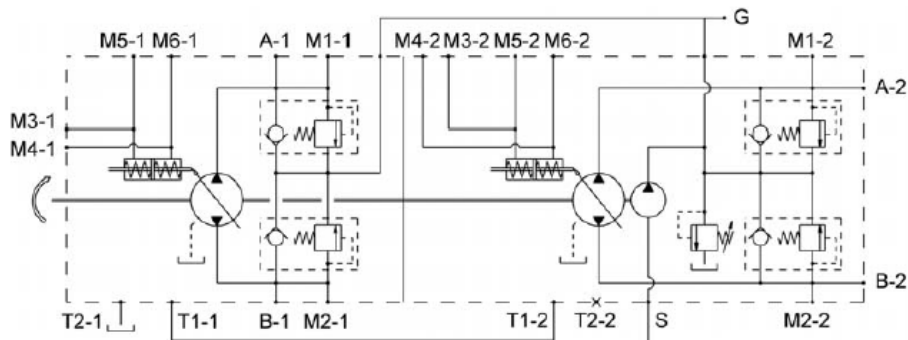

Differential pressure

The differential pressure is the High pressure relief valve setting minus Charge relief valve setting.

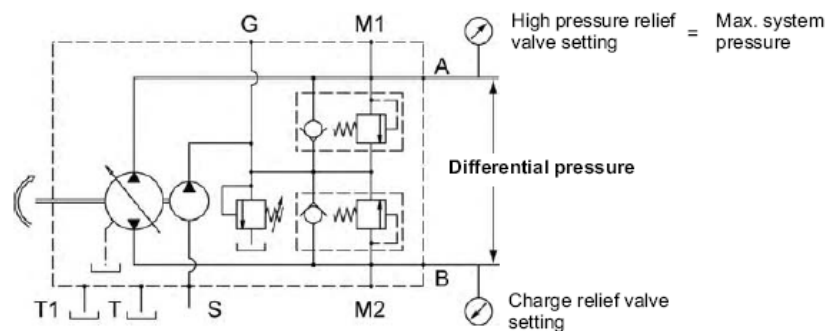

Bearing life and external shaft loading

Bearing life:

Bearing life is a function of speed, pressure, swashplate angle and external loads. Oil type and viscosity impact bearing life.

	Bearing life (B ₁₀ hours)
PMV0-07	32 560
PMV0-09	15 480
PMV0-11	6 990
PMV0-14	4 500
PMV0-18	2 300

Shaft Loads

Normal bearing life in B₁₀ hours is shown in the above table. Figures have been calculated under the following operating conditions : a continuous differential pressure of 120 bar [1 740 PSI], 1 800 rpm shaft speed, maximum displacement, without any external shaft side load. The data is based on a 50% forward, 50% reverse duty cycle, standard charge pump size, and standard charge pressure (20 bar [290 PSI]).

PMV0 pumps are designed with bearings that can accept external radial and thrust loads. The external radial shaft load limits depend on the load position, orientation, and operating conditions of the unit.

The maximum permissible radial load (Re), is based on the maximum external moment (Me), and the distance (L) from the mounting flange to the load. It may be determined using the table and formula below. Thrust (axial) load limits are also shown.

$$Re = Me / L$$

All external shaft loads affect bearing life. In applications with external shaft loads, minimize the impact by positioning the load at 90° or 270° as shown in the figure.

Contact your Poclair Hydraulics representative for an evaluation of unit bearing life if:

- Continuously applied external loads exceed 25 % of the maximum allowable radial load Re.
- The pump swashplate is positioned on one side of center all or most of the time.
- The unit bearing life (B₁₀) is critical.

	PMV0-07	PMV0-09	PMV0-11	PMV0-14	PMV0-18
External moment (Me) N.m [in.lbf] (Based on shaft deflection)	66	60	51	45	35

Radial and thrust load position

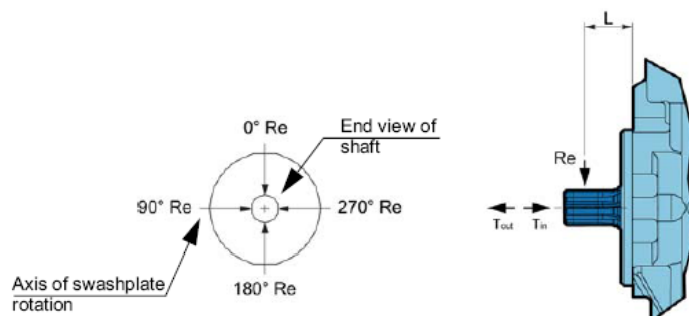

Hydraulic unit life

Hydraulic unit life is the life expectancy of the hydraulic components. It depends on speed and system pressure even if, system pressure is the dominant operating variable. High pressure, generated by high load, reduces hydraulic unit life.

Design the hydraulic system according to the expected machine duty cycle. Take in consideration the expected percentages of time at various loads and speeds. Ask your Poclain Hydraulics representative to calculate an appropriate pressure based your hydraulic system design. If duty cycle data is not available, input power and pump displacement are used to calculate system pressure.

All pressure limits are differential pressures (referenced to charge pressure), taking a normal charge pressure in consideration.

PMV0 pumps will meet satisfactory life expectancy if applied within the parameters specified in this technical documentation. For more detailed information on hydraulic unit life see Operating Parameters in page 9.

Mounting flange loads

Adding tandem mounted pumps, and/or tandem auxiliary pump(s), subjecting pumps to shock loads may generate excessive loads on the front mounting flange. The overhung load moment for multiple pump mounting can be estimated as shown in the figure below

Overhung load example

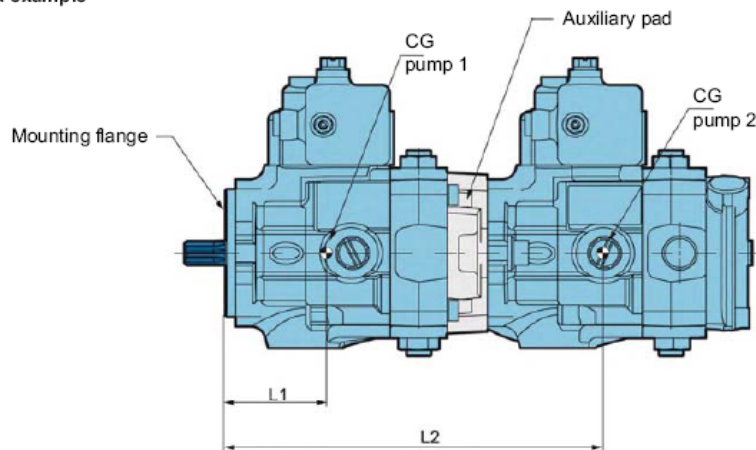

Estimating overhung load moments

W = Weight of pump (kg)

L = Distance from mounting flange to pump center of gravity (CG)

$$M_R = G_R (W_1 L_1 + W_2 L_2 + \dots + W_n L_n)$$

$$M_S = G_S (W_1 L_1 + W_2 L_2 + \dots + W_n L_n)$$

Where:

M_R = Rated load moment (N.m)

M_S = Shock load moment (N.m)

G_R^* = Rated (vibratory) acceleration (G's) (m/sec²)

G_S^* = Maximum shock acceleration (G's) (m/sec²)

*Calculations will be carried out by multiplying the gravity ($g = 9.81 \text{ m/sec}^2$) with a given factor. This factor depends on the application.



For an accurate calculation, consult your Poclain Hydraulics application engineer.



FEATURES

High pressure relief valve

The High pressure relief valves maintain circuit pressure in the proper range. The check valves allow charge flow to replenish the low pressure loop of the circuit. The high pressure relief valves ensure a high pressure protection of the high pressure loop of the circuit.

High pressure relief valves are available in a range of settings.

When high pressure relief valves are not desired, pumps is equipped with charge circuit check valves only.



High pressure relief valves are intended for transient overpressure protection and are not intended for continuous pressure control. Flow over relief valves for extended periods of time may result in severe heat build up. High flows over relief valves may result in pressure levels exceeding the nominal valve setting and potential damage to system components.



High pressure relief valve	Available setting bar [PSI]	
Without	-	00
	100 [1 450]	10
With	150 [2 175]	15
	200 [2 900]	20
	250 [3 625]	25
	300 [4 351]	30

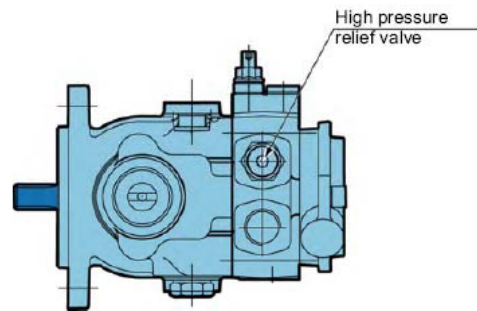
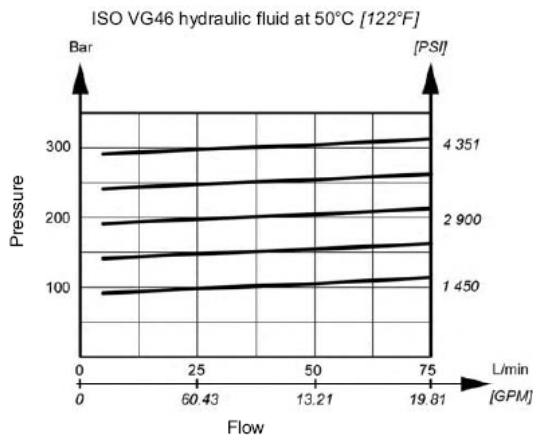
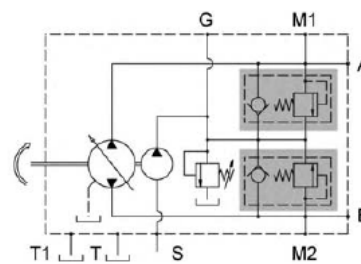

The high pressure relief valve setting is not the differential pressure between A and B ports (see page 13).



Charge relief valve

The charge pressure relief valve provides a relief outlet for charge circuit. This valve is used to set the charge pressure of the circuit. Flow through the valve is ported to case.

The nominal charge relief setting is referenced to case pressure.



Incorrect charge pressure settings may result in the inability to build required system pressure and/or inadequate loop flushing flows. Ensure correct charge pressure under all conditions of operation to maintain pump control performance.



Charge relief valve	Available setting bar [PSI]	
Without	-	00
With	Only for controls M and N	10
	For all controls	20

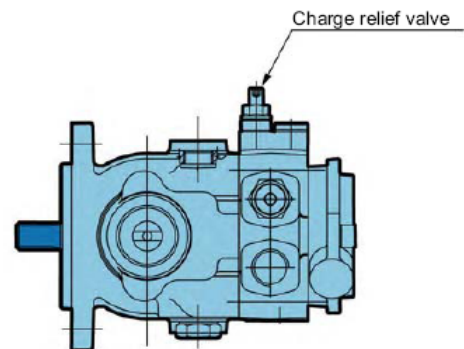
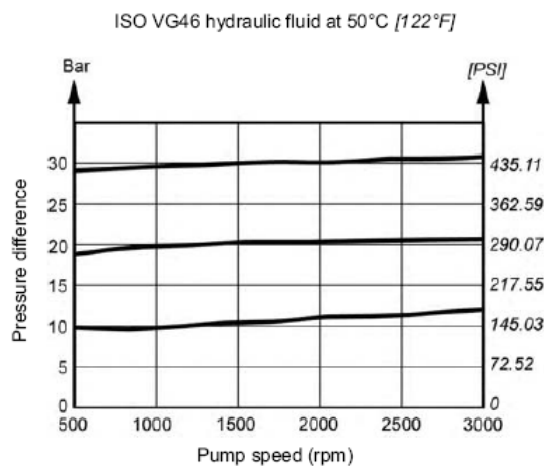
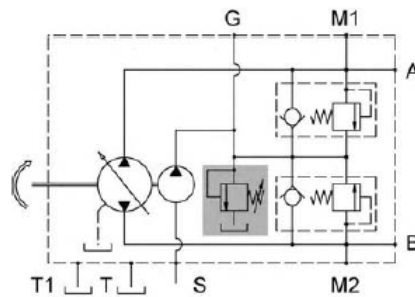

Charge pump

Charge flow is required on all PMV0 pumps used in closed circuit installations. The charge pump provides flow to make up internal leakage, maintain a positive pressure in the main circuit, provide flow for cooling and filtration, replace any leakage losses from external valving or auxiliary systems, and to provide flow and pressure for the control system.

Many factors influence the charge flow requirements. These factors include system pressure, pump speed, pump swashplate angle, type of fluid, temperature, size of heat exchanger, length and size of hydraulic lines, control response characteristics, auxiliary flow requirements, hydrostatic motor type, etc.

Unusual application conditions may require a more detailed review of charge pump sizing. Charge pressure must be maintained at a specified level under all operating conditions to prevent damage to the transmission. Poclain Hydraulics recommends testing under actual operating conditions to verify this.

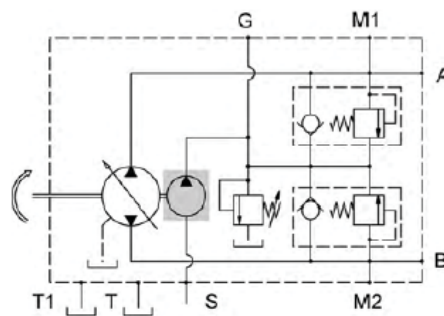

Charge pump sizing/selection

In most applications, a general guideline is that the charge pump displacement should be at least 20% of the main pump displacement.

1
 2
 3
 4
 5
 6
 7
 8
 9
 10
 11
 12

Charge pump	Displacement cm ³ /rev [in ³ /rev]	Rated speed (rpm)	
Without	-	-	00
With	4,9 [0.30]	3900	05



Contact your Poclain Hydraulics application engineer for more information.



Displacement limiters

PMV0 with hydraulic servo control (S) are designed with mechanical displacement (stroke) limiters. You can limit maximum displacement of the pump to a certain per-cent of its maximum displacement to near zero in both direction.

The displacement limiters are located on the both sides of the servo piston and are adjustable by screw.



Take care in adjusting displacement limiters to avoid an undesirable condition of output flow or speed. Retorque the sealing lock nut after every adjustment to prevent an unexpected change in output conditions and to prevent external leakage during pump operation.

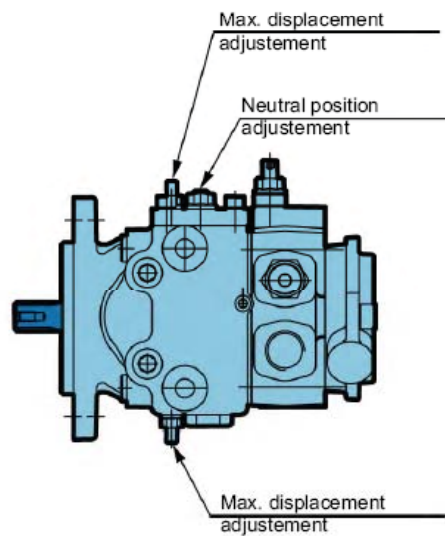

By-pass

See "Options" chapter page 33 for more information.

Mounting flange and shafts

SAE A - Splined shaft



S1 9 teeth; Max torque: 80 N.m [708 in.lbf]

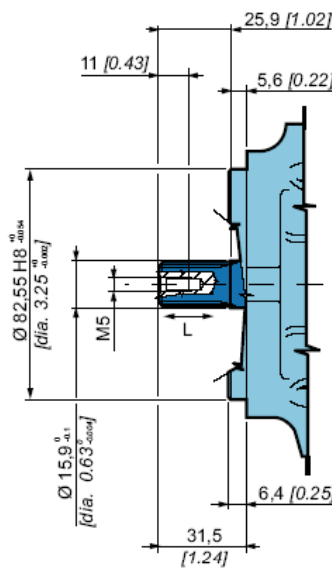

Splined ANSI B92.1a-1976
Pitch 16/32" DP
Pressure angle: 30°
Tolerance class: 5
Thread M5 UNI 9321

Effective length (L) = $17,5^{+1,5}_0$ [0.69^{+0.06}]

S2 11 teeth; Max torque: 140 N.m [1 239 in.lbf]

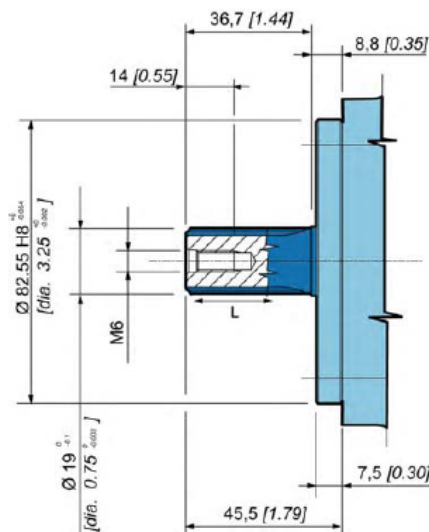

Splined ANSI B92.1a-1976
Pitch 16/32" DP
Pressure angle: 30°
Tolerance class: 5
Thread M6 UNI 9321

Effective length (L) = $27,2^{+1,5}_0$ [1.07^{+0.06}]



SAE A - Key shaft

P	M	V	0	1	2	3	4	5	6	7	8	9	10	11	12
---	---	---	---	---	---	---	---	---	---	---	---	---	----	----	----

C1 Ø 15,875 [dia. 0.624]; Max. torque: 65 N.m [575 in.lbf]

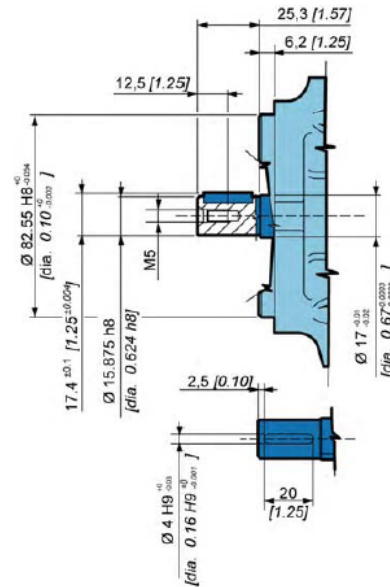

Thread M5 UNI 9321

D2 Ø 18 [dia. 0.71]; Max. torque: 100 N.m [885 in.lbf]

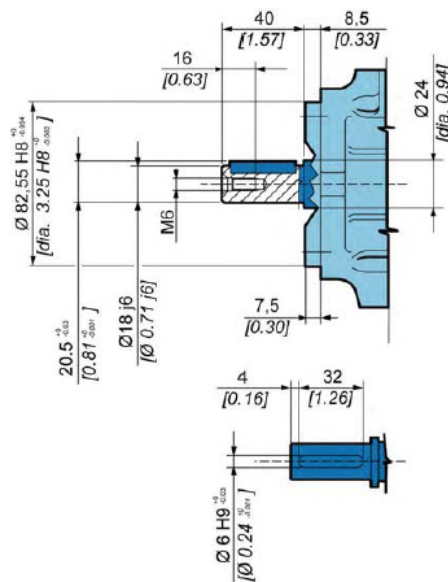

Thread M6 UNI 9321

Auxiliary mounting pad

German group 1

Max. torque: 48 N.m [425 in.lbf]



00 Without charge pump

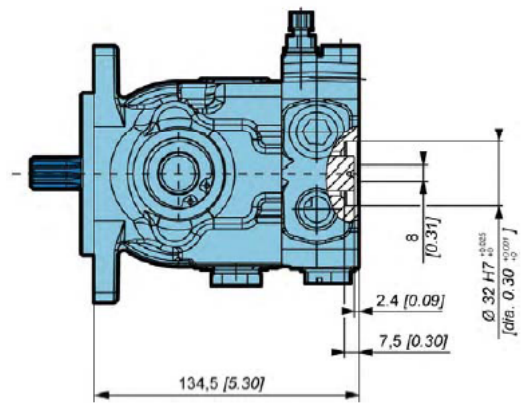
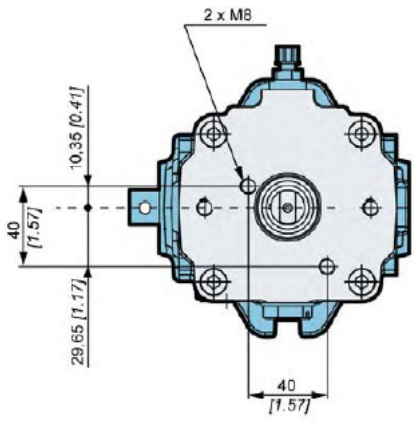

05 With charge pump: 4.9 cm³/rev [0.30 in³/rev]

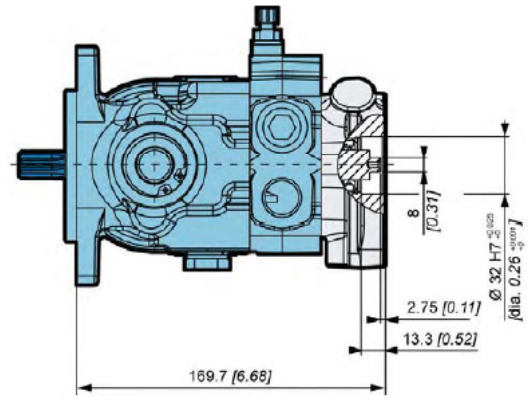
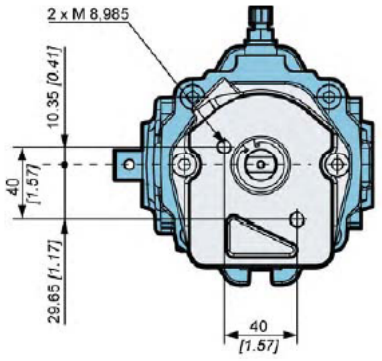

Do not rotate the auxiliary mounting pad cover.



German group 2

Max. torque: 70 N.m [620 in.lbf]



00 Without charge pump

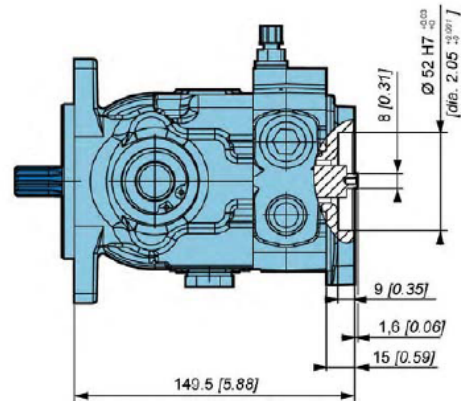
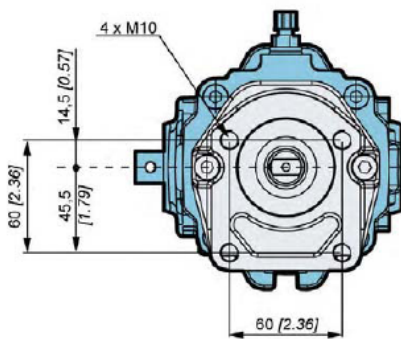

05 With charge pump: 4,9 cm³/rev [0.30 in³/rev]

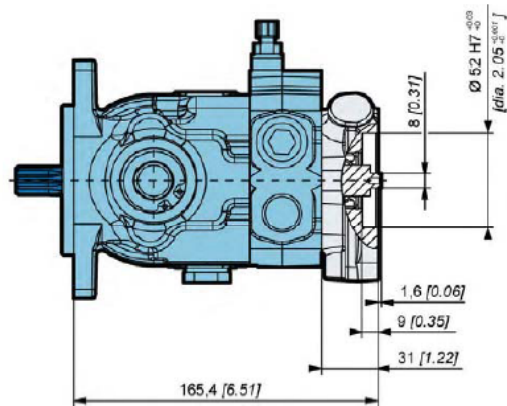
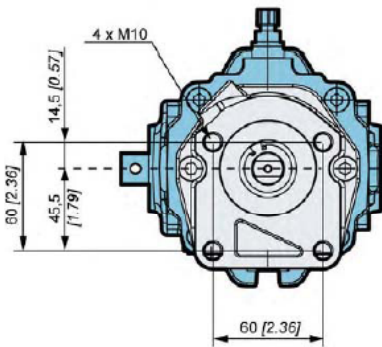

Do not rotate the auxiliary mounting pad cover.



Tandem pumps

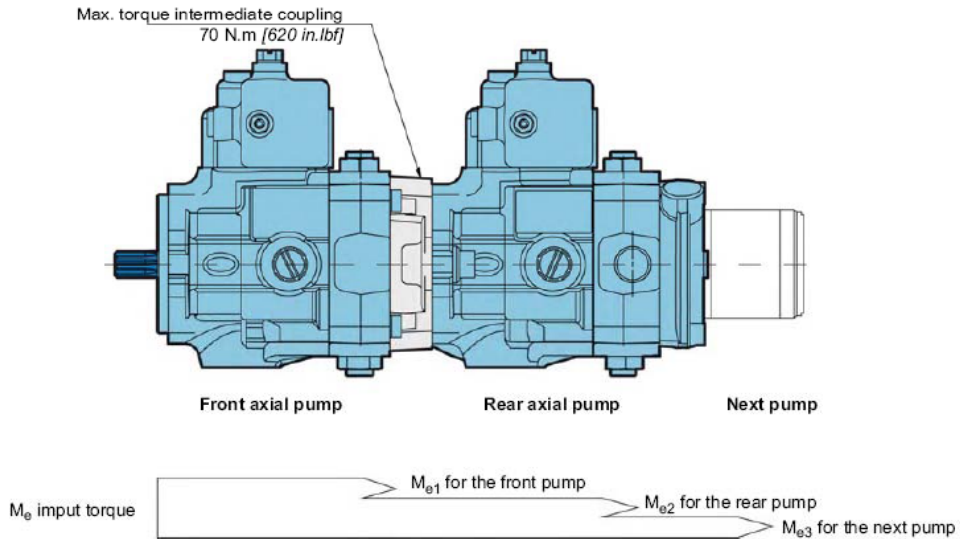

Torque required by auxiliary pumps is additive. Ensure requirements don't exceed shaft torque ratings.



Number of charge pump in the tandem	Axial pump	Mounting flange and shaft		Charge pump	Auxiliary mounting flange	
0 charge pump	Front	SAE A; 9 teeth	S1	Without	00	Tandem fitting
		SAE A; 11 teeth	S2			
		Key shaft Ø 18 [dia. 0.71]	D2			
	Rear	Shaft for secondary tandem pump	T1	Without	00	Without auxiliary mounting pad
					German group 1	F
					German group 2	G
1 charge pump*	Front	SAE A; 9 teeth	S1	Without	00	Tandem fitting
		SAE A; 11 teeth	S2			
		Key shaft Ø 18 [dia. 0.71]	D2			
	Rear	Shaft for secondary tandem pump	T1	With	05	Without auxiliary mounting pad
					German group 1	F
					German group 2	G

*** The charge pump can only be located on the rear axial pump.**



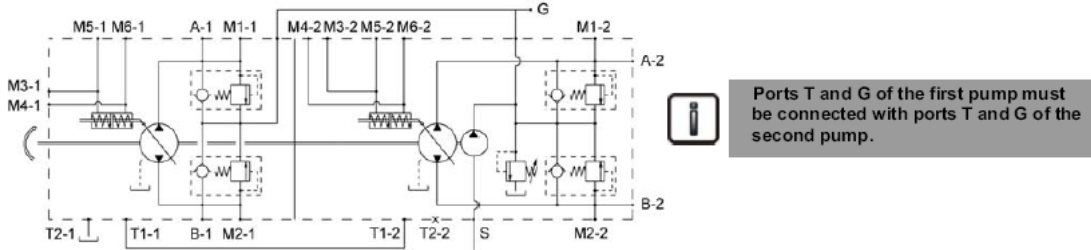

Gear pumps

1 2 3 4 5 6 7 8 9 10 11 12

P M V O

Auxiliary mounting pad Gear pump

	Displacement cm ³ /rev [cu.in/rev]	Pressure			Dimension			Mass Kg [lb]	Efficiency %	
		Continuous max. pressure bar [PSI]	Max. intermittent pressure bar [PSI]	Max. peak pressure bar [PSI]	A mm [in]	B mm [in]	C mm [in]			
German group 1 	01	1,6 [0.10]	210 [3 045]	240 [3 480]	260 [3 770]	76,4 [3.01]		0,95 [2.09]	95*	
	02	2,0 [0.12]	210 [3 045]	240 [3 480]	260 [3 770]	77,9 [3.07]		0,97 [2.14]		
	03	3,2 [0.19]	200 [2 900]	240 [3 480]	250 [3 625]	82,6 [3.25]	67 [2.64]	70 [2.76]		1,04 [2.29]
	04	4,2 [0.26]	180 [2 610]	210 [3 045]	230 [3 335]	86,5 [3.41]				1,10 [2.43]
	05	5,0 [0.30]	180 [2 610]	210 [3 045]	230 [3 335]	89,6 [3.53]				1,14 [2.51]
	06	6,3 [0.38]	170 [2 465]	190 [2 755]	210 [3 045]	94,7 [3.73]				1,22 [2.69]
German group 2 	04	4,5 [0.27]	250 [3 625]	270 [3 915]	290 [4 205]	90,3 [3.55]		2,30 [5.07]	95*	
	06	6,0 [0.37]	250 [3 625]	270 [3 915]	290 [4 205]	93,6 [3.68]		2,45 [5.40]		
	08	8,5 [0.52]	250 [3 625]	270 [3 915]	290 [4 205]	97,8 [3.85]		2,60 [5.73]		
	11	11,0 [0.67]	250 [3 625]	270 [3 915]	290 [4 205]	101,9 [4.01]	88 [3.46]	100 [3.94]		2,70 [5.95]
	14	14,0 [0.85]	250 [3 625]	270 [3 915]	290 [4 205]	106,9 [4.21]				2,80 [6.17]
	16,5	16,5 [1.01]	230 [3 335]	240 [3 480]	250 [3 625]	111,1 [4.37]				2,95 [6.51]
	17	16,5 [1.01]	230 [3 335]	240 [3 480]	250 [3 625]	111,1 [4.37]				2,95 [6.51]
	20	19,5 [1.19]	210 [3 045]	220 [3 190]	230 [3 335]	116,1 [4.57]				3,10 [6.84]

* Value collected during the testing at 1500 rpm

Gear pumps are always delivered flanged on the axial pump. They can not be sold alone.



CONTROLS

Direct mechanical control



The variation in pump displacement is obtained by rotating the lever shaft in a clockwise or counter-clockwise direction.

The lever shaft is directly linked to the pump swashplate. The max. angle is at 18°.

Flow rate determination

Rotation	Pressure	Output	Input
Clockwise (R)	X	A	B
	Y	B	A
Counter clockwise (L)	X	B	A
	Y	A	B

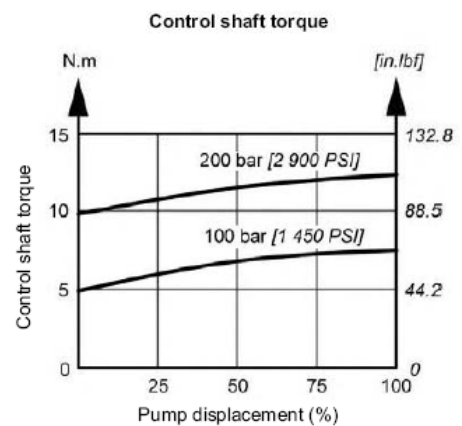
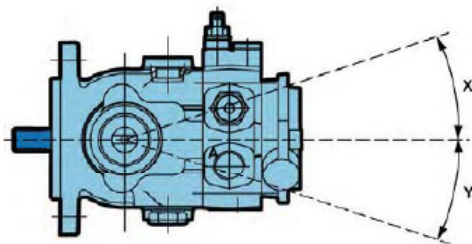
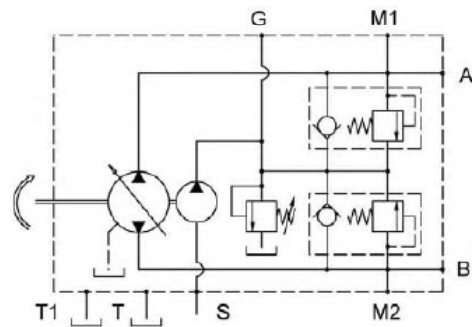



Control Position

Control on the top

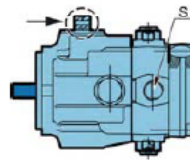

A0

Control at the bottom

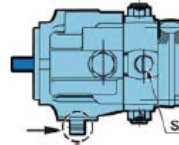

B0

Dimensions

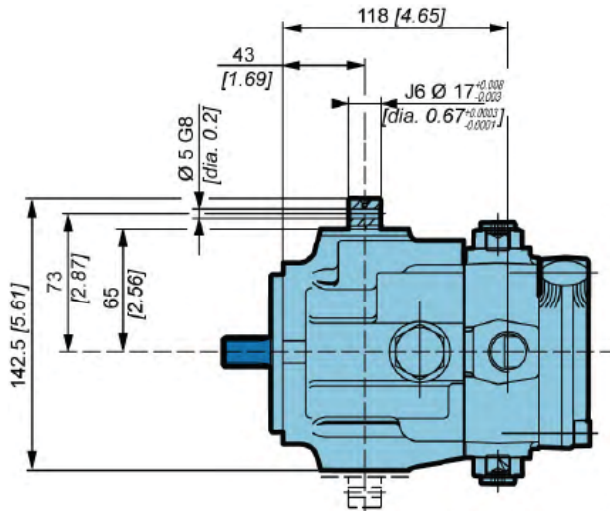

See page 7 for other dimensions and port characteristics.

Direct mechanical control with return spring



The variation in pump displacement is obtained by rotating the lever shaft in a clockwise or counter-clockwise direction.

The lever shaft is directly linked to the pump swashplate. The max. angle is at 18°.

Flow rate determination

Rotation	Pressure	Output	Input
Clockwise (R)	X	A	B
	Y	B	A
Counter clockwise (L)	X	B	A
	Y	A	B

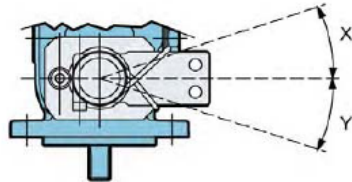
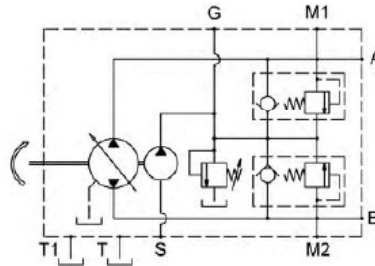

Diameter of spring mm [in]

3,5 [0.14]	35
3,8 [0.15]	38
4,0 [0.16]	40
4,2 [0.17]	42

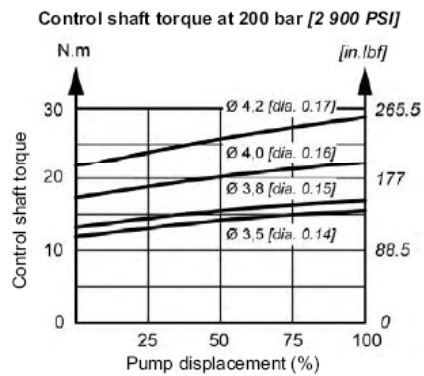
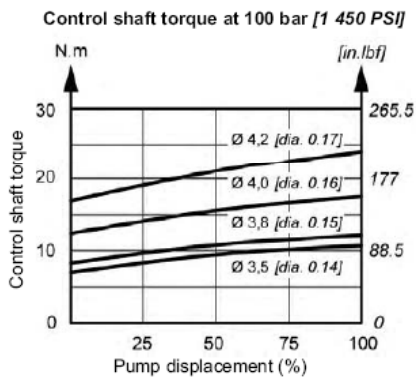

The spring return feature in the control unit is not a safety device.





Control position

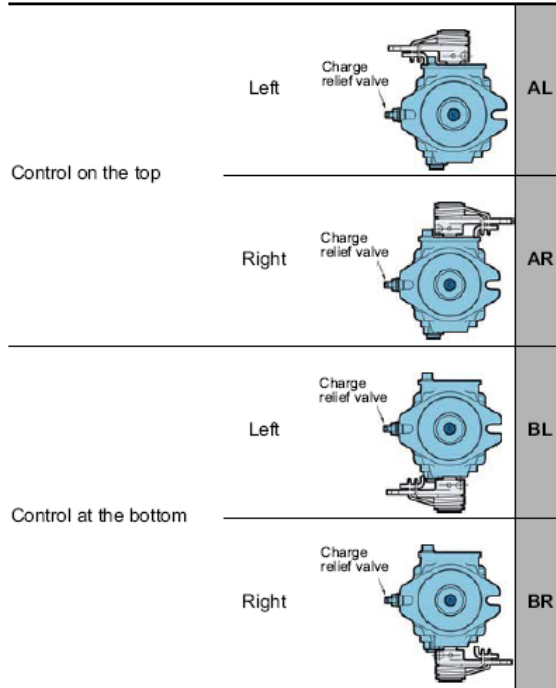

Dimensions

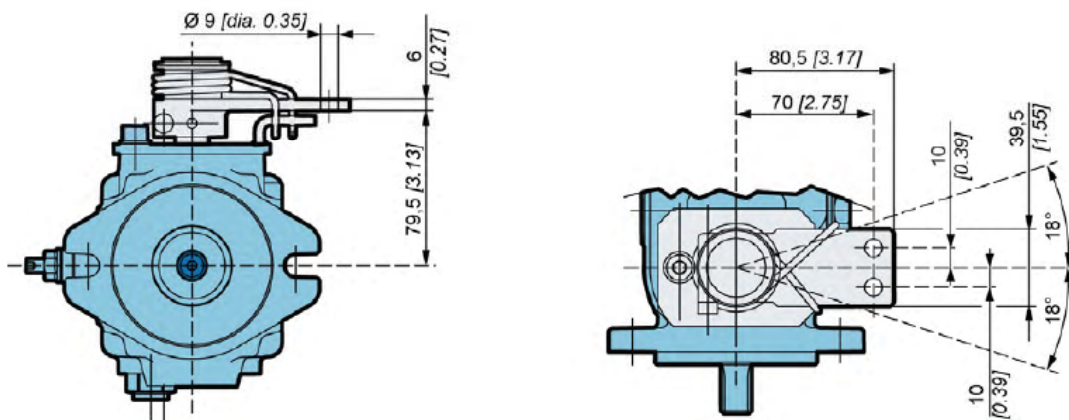

See page 7 for other dimensions and port characteristics.



Hydraulic servo control



The variation in pump displacement is obtained by adjusting the pressure on the M3 and M4 or M5 and M6 servo control connections by means of a hydraulic proportional joystick (containing pressure reduction valves).

The joystick supply can be obtained by taking pressure from the auxiliary pump (G connection).

The servo control timing can be adjusted by inserting a restrictor on the joystick supply line (from 0.5 to 1,2 mm [from 0.02 to 0.05 in]) or between the joystick and servo piston of the pump.

The servo control operation curve in both control directions goes from 4 to 11 bar [from 58 to 159 PSI] (tolerance $\pm 5\%$). The adjustment curve of the hydraulic control system has to be wider (from 4 to 15 bar [from 58 to 217 PSI]).

Flow rate determination

Rotation	Pressure	Output	Input
Clockwise (R)	M3 - M5	B	A
	M4 - M6	A	B
Counter clockwise (L)	M3 - M5	A	B
	M4 - M6	B	A

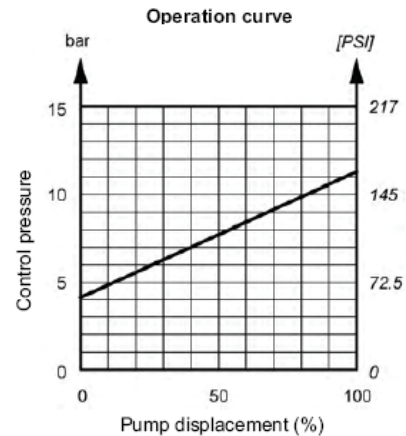
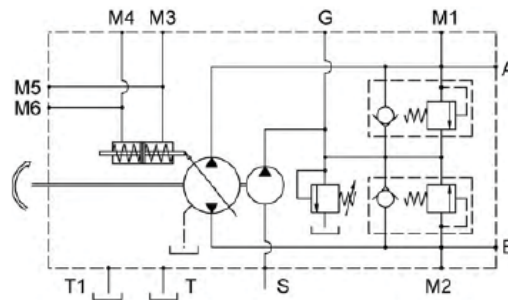

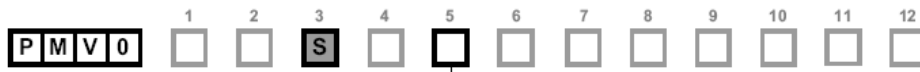

Control position

Control on the top

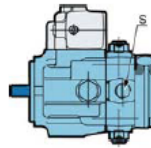

A0

Control at the bottom

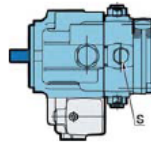

B0

Dimensions

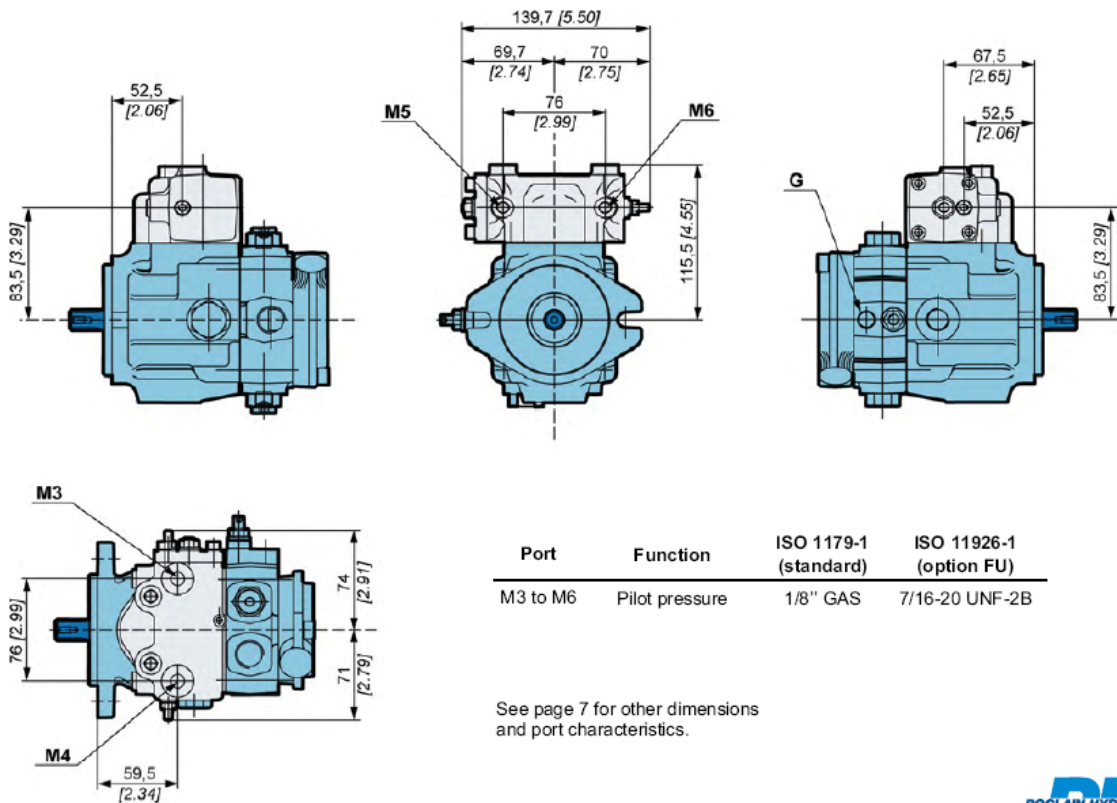

OPTIONS

Screw by-pass



PMV0 features a by-pass function. By-passing Port A and Port B is achieved by unscrewing a screw located on the cover. The by-pass connect the ports A-B and must be use only in emergency case and only for short movement.

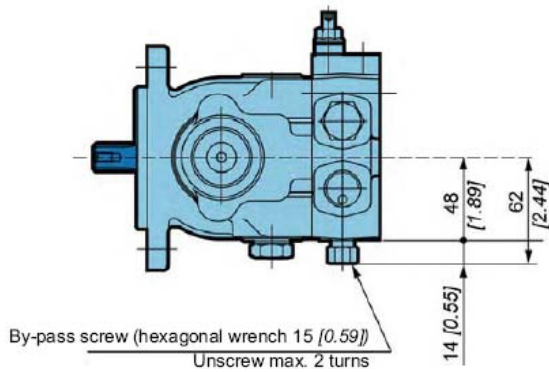
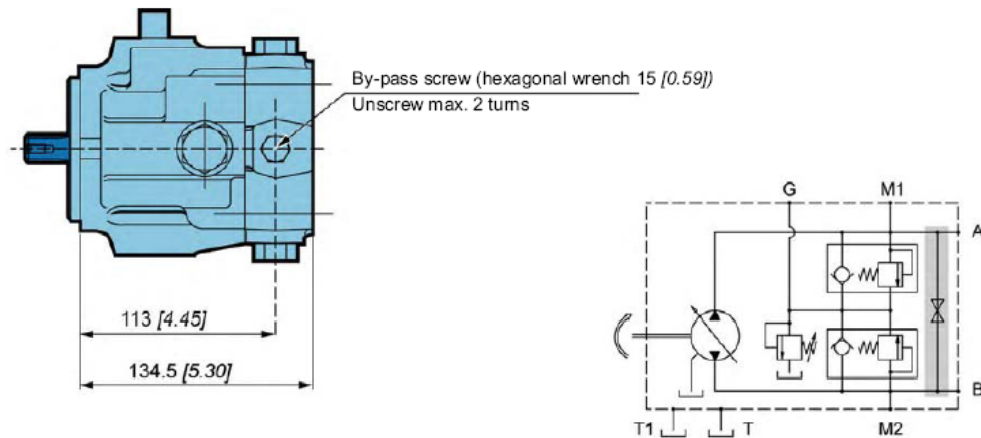

The screw by-pass is only available without charge pump.



To avoid leakage, do NOT exceed two turns of the screw.



By-pass valve is intended for moving a machine for very short distances at very slow speeds. It is NOT intended as tow valve.

Lever by-pass

P	M	V	0	1	2	3	4	5	6	7	8	9	10	11	12
				<input type="checkbox"/>	<input type="checkbox"/>	<input type="checkbox"/>	<input type="checkbox"/>	<input type="checkbox"/>	<input type="checkbox"/>	<input type="checkbox"/>	<input type="checkbox"/>	<input type="checkbox"/>	<input type="checkbox"/>	<input type="checkbox"/>	<input checked="" type="checkbox"/> BL

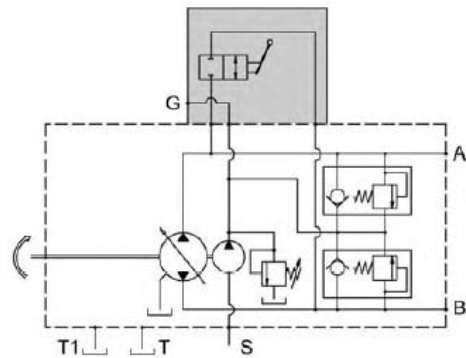
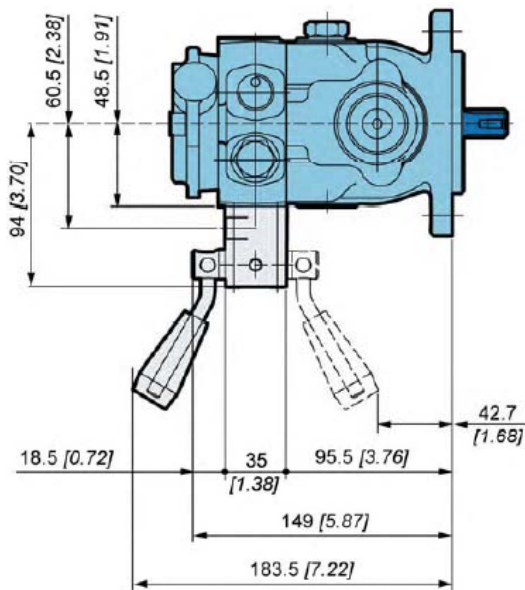
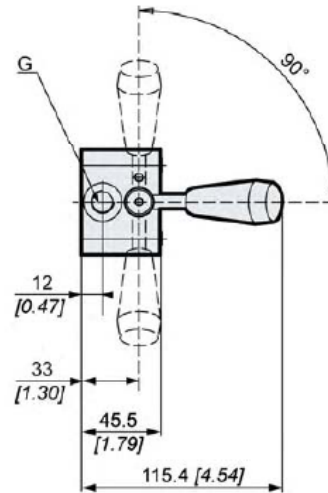
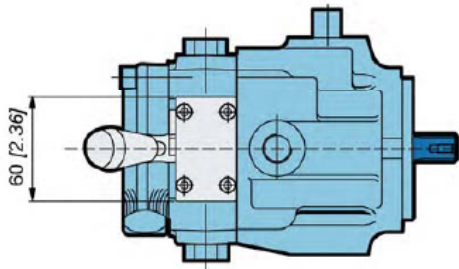

By-pass valve is intended for moving a machine for very short distances at very slow speeds. It is NOT intended as tow valve.



Electrical by-pass with brake engaged



BF option is a safety feature.

Without electrical control, pump is in by-pass and parking brake is applied (there is no charge pressure on C3 port).

With electrical control, pump is not in by-pass and parking brake can be release (there is charge pressure on C3 port).

Supply voltage	
12V	BF12
24V	BF24

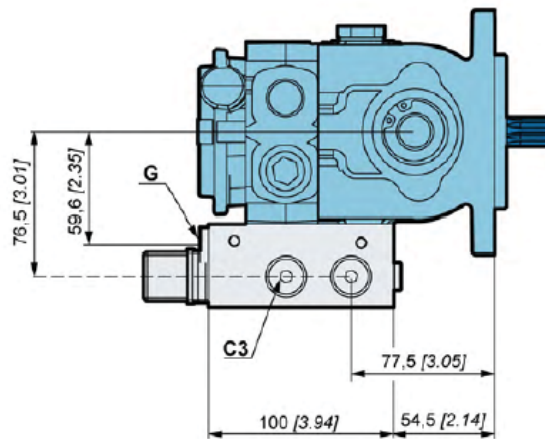
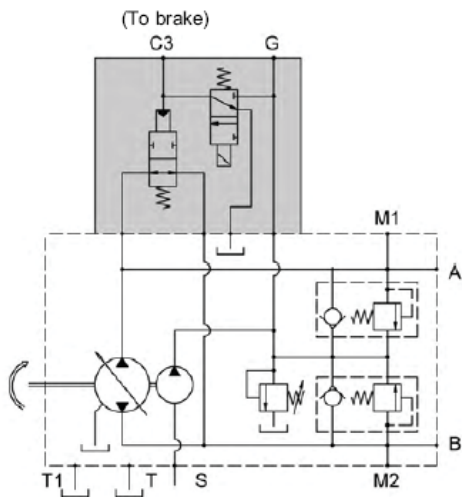
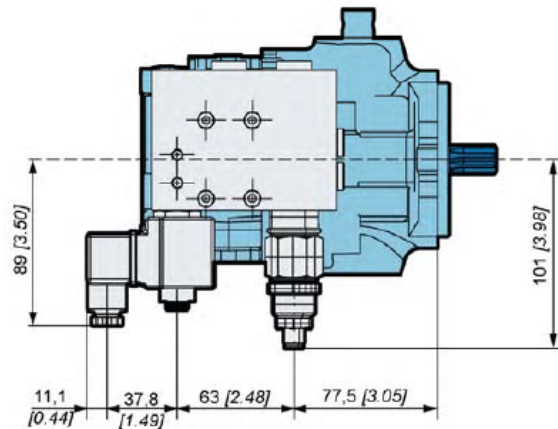
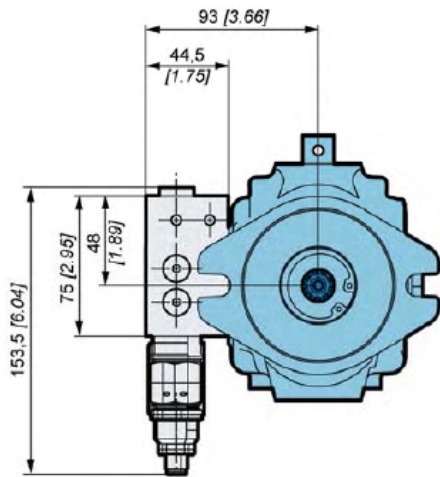

Type of connector: DIN 43650



Roller bearing

1 2
 3 4 5 6 7 8 9 10 11 12
P M V 0 **S1** or **C1** **CR**

It is an optional high capacity bearing.

Depending on the characteristics of the shaft load, the duty cycle of the application and the expected life time of your application, Roller bearing might be needed.

Consult your Poclairn Hydraulics Application Engineer.

Fluorinated elastomer seals

1 2 3 4 5 6 7 8 9 10 11 12
P M V 0 **EV**

Standard NBR sealing are designed to resist to temperature up to 90°C [194°F] and to HV type oils.

If your application is outside these limits, Fluorinated elastomer seals might be recommended.

Consult your Poclairn Hydraulics Application Engineer.

UNF threads ports

1 2 3 4 5 6 7 8 9 10 11 12
P M V 0 **FU**

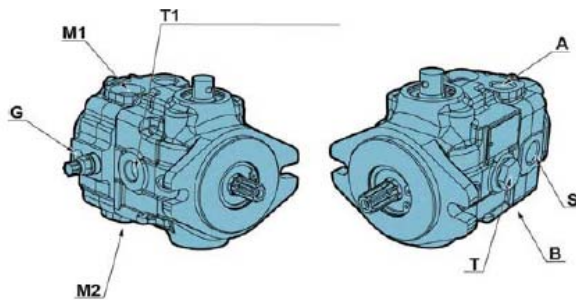

Port	Function	ISO 11926-1
A-B	Services	3/4-16 UNF-2B
G	Auxiliary	7/16-20 UNF-2B
M1/M2	Gauge	-
S	Suction	3/4-16 UNF-2B
T/T1	Drain	3/4-16 UNF-2B

Low noise valve plate

1 2 3 4 5 6 7 8 9 10 11 12
P M V 0 **DB**

Special valve plate designed to reduce noise of the pump.



Filter on suction line



The max. pressure drop on the filtration element must not exceed 0,4 bar absolute [5.8 PSI absolute] (0,8 bar absolute [11.6 PSI absolute] with cold starting).

The "S" suction port can be orientated of 360°.

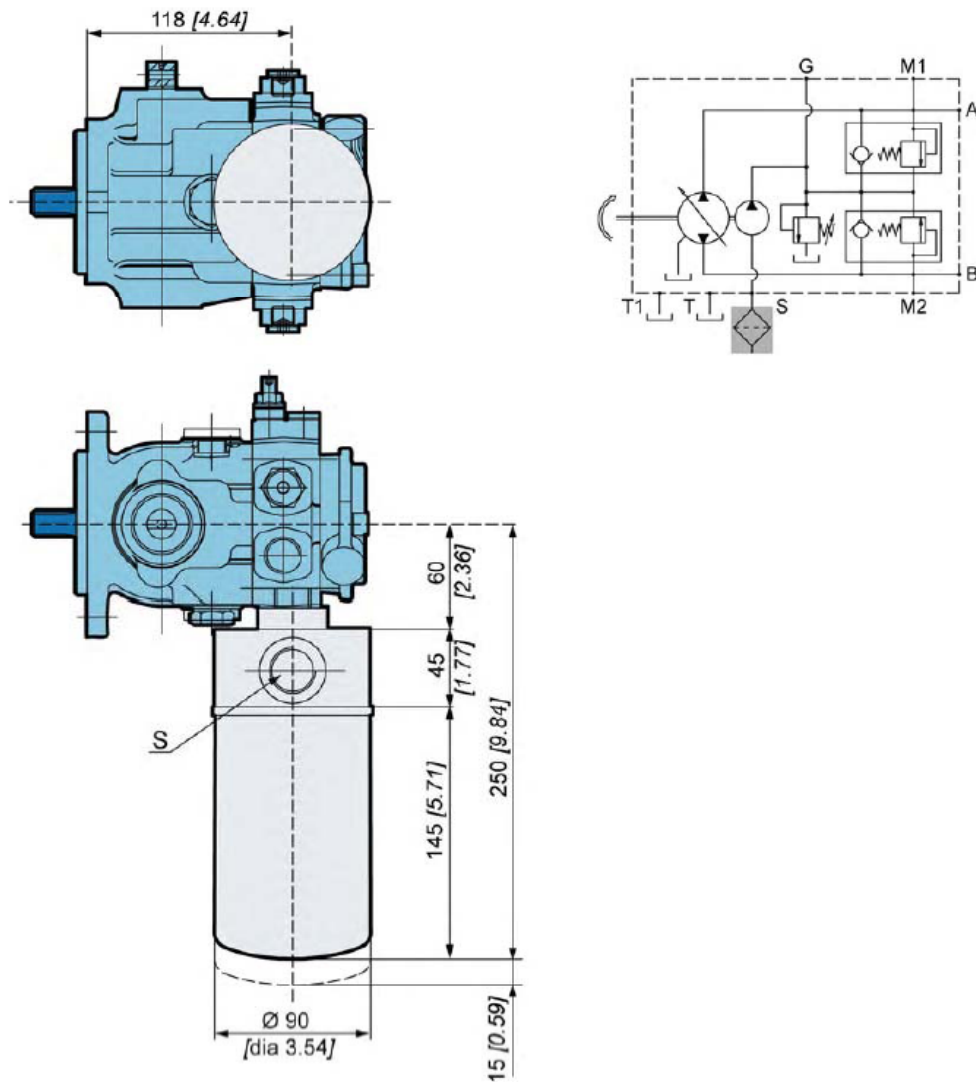

Filter on pressure line

The PMV0 pumps can have a pressure filter without clogging indicator (F0) or with clogging indicator (F2). The flow thru the filter is only the flow that entry in the close loop. The filter fitness is of 10 micron.

Maximum pressure difference between filter cartridge input and output is 2 bar [29 PSI]. When reaching 2 bar [29 PSI], the cartridge has to be changed.

Max. working pressure: 10 bar [145 PSI].

Tightening torque: 35 Nm [309 in.lbf].

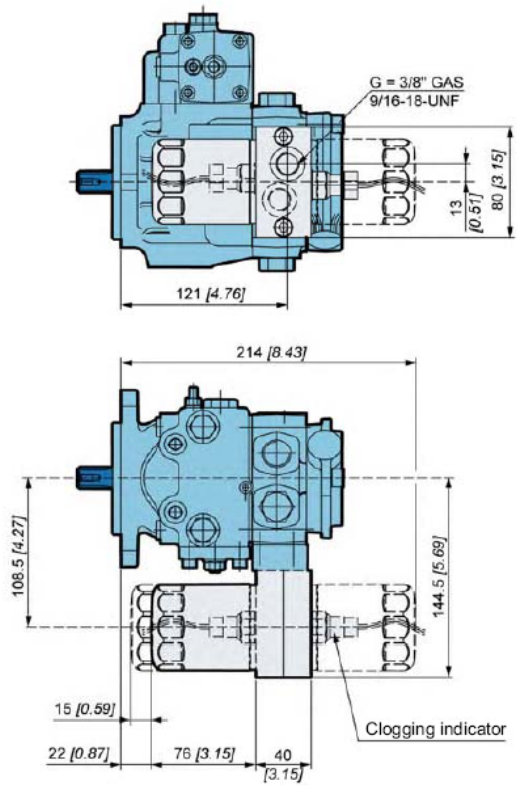
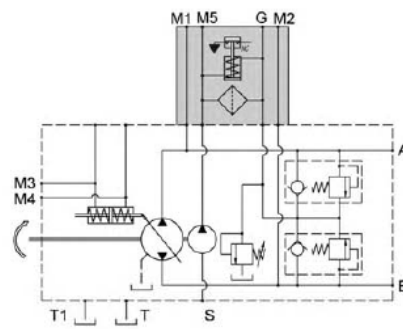
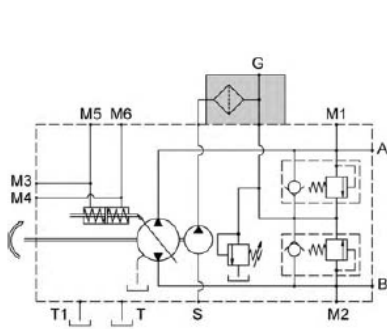

Swashplate on bushing



Swashplate mounted on bushing instead of bearing for lower noise working pump.

Flushing valve



Inside the pump cover, a flushing valve can be fitted with discharge inside the pump casing by means of a calibrated hole. The flushing valve is useful in case the temperature of the oil in the closed circuit is too high.

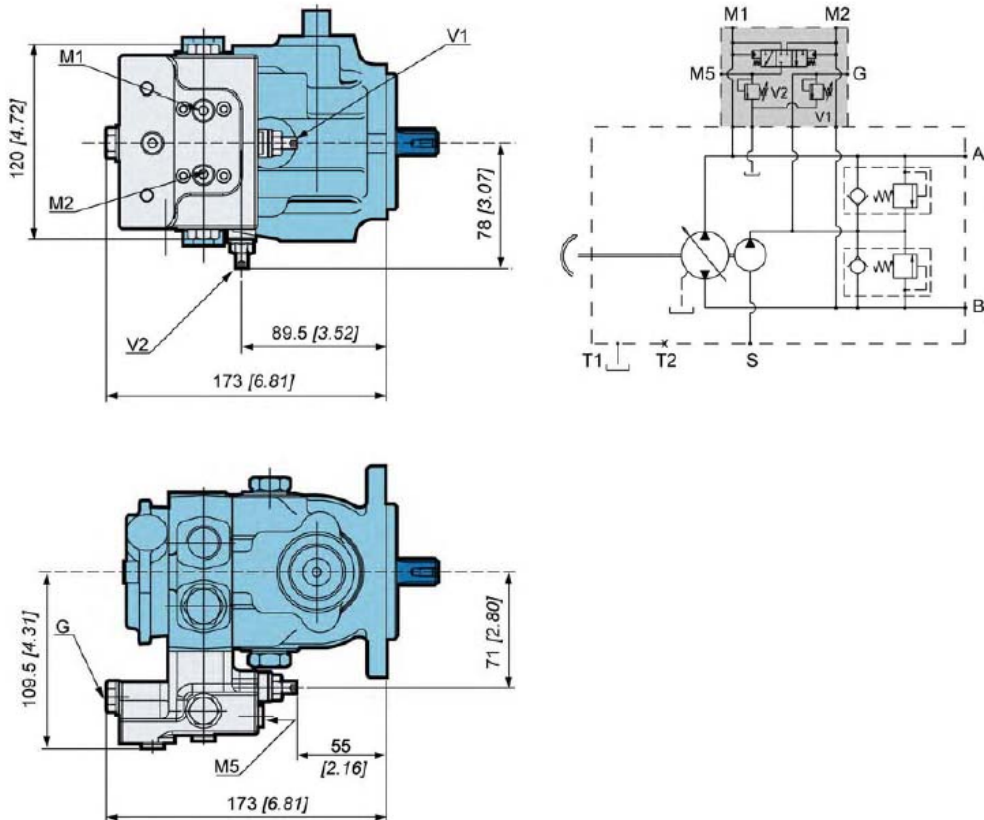

Pressure gauge ports on relief valve



Pressure port for pressure measurement.

