



PM50 PUMPS



PM50 – 40. HYDRAULIC PUMPS.

OVERVIEW

PM50 is a variable displacement, axial piston pump, with swashplate system, for closed loop hydrostatic transmissions.

It provides a continuously variable flow rate between zero and maximum in forward and reverse direction. Flow rate is proportional to rotation speed and swashplate angle.

It can feature a charge pump to keep the circuit pressurised. This avoids risk of cavitations and ensures a good performance of the transmission.

It offers several types of control: Hydraulic, electrical and electro-proportional. Hydraulic and electro-proportional ones can be equipped with feed-back device.

It is equipped with high pressure relief valves and can be delivered with auxiliary gear pumps.

It is available in single or tandem versions.

As options, PM50 can be featured with flushing valve and filter on charge pressure line.

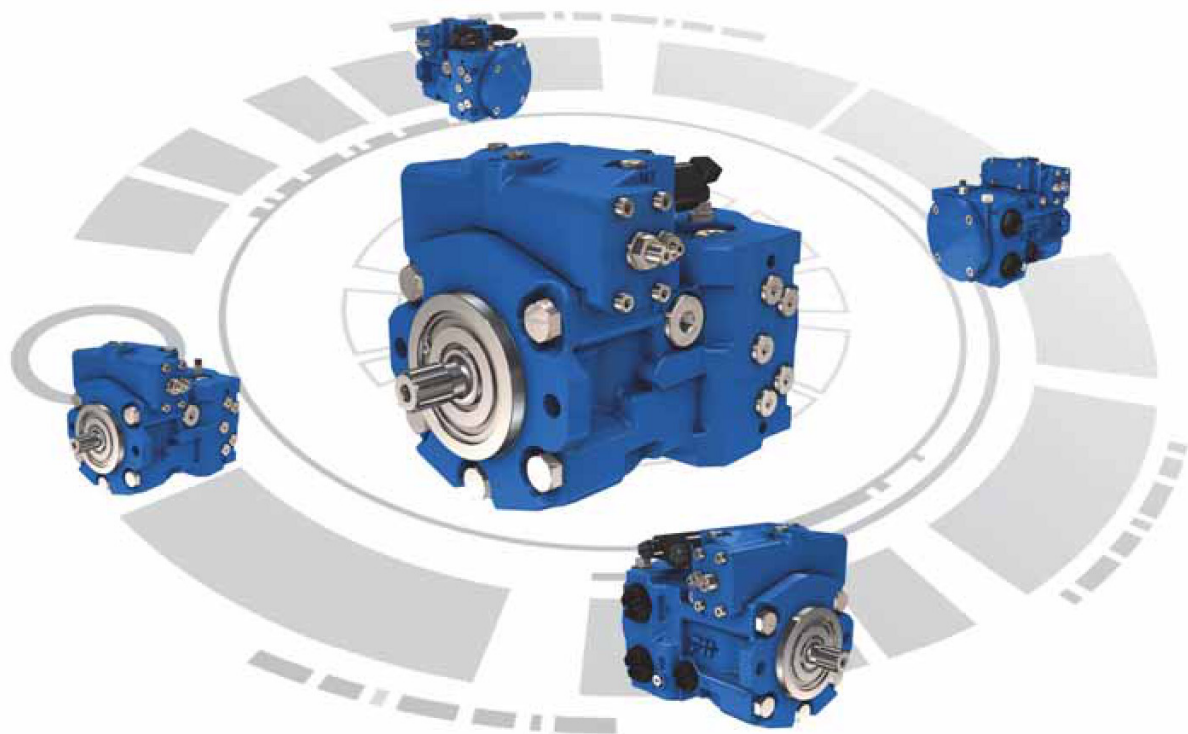

| | | PM50-40 | PM50-45 | PM50-52 |
|---|---|----------------|---|------------------|
| Displacement | cm ³ /rev [in ³ /rev.] | 40 [2.44] | 45 [2.75] | 52 [3.17] |
| Theoretical Flow at rated speed | L/min [GPM] | 144 [38.04] | 162 [42.79] | 187,2 [49.45] |
| Max. Theoretical absorbed power at 320 bar [4 641 PSI] | kW [hp] | 76,8 [103] | 86,4 [116] | 99,8 [134] |
| Theoretical absorbed torque at 100 bar [1 450 PSI] | N.m [in.lbf] | 63,7 [564] | 71,7 [635] | 82,8 [733] |
| Moment of inertia | kg.m ² [slug.ft ²] | | 0.0054 [0.0038] | |
| Mounting flange | | | SAE B, SAE BB | |
| Controls | | | Servo hydraulic, electrical, electro-proportional | |
| Mass | kg [lb] | | 32 [70.5] with servo control S | |
| Rotation | | | Clockwise or Counterclockwise | |

CONTENT



| | | |
|--|-----------|--------------------------|
| MODEL CODE | 4 | Model Code |
| TECHNICAL SPECIFICATION | 6 | |
| Port characteristics | 6 | Technical specifications |
| Main dimensions | 7 | |
| OPERATING PARAMETERS | 9 | |
| Operating parameters | 9 | |
| Charge pressure | 9 | |
| Case pressure | 9 | |
| Pressure ratings | 9 | |
| Speed ratings | 9 | |
| Inlet pressure | 10 | |
| Theoretical output | 10 | |
| Poclair Hydraulics recommendations for fluid | 10 | |
| Fluid and filtration | 11 | |
| Viscosity range | 11 | |
| SYSTEM DESIGN PARAMETERS | 12 | Operating Parameters |
| Sizing equations | 12 | |
| Redundant braking system requirement | 12 | |
| Loop flushing | 12 | |
| Reservoir | 13 | |
| Case drain usage for tandem pump | 13 | |
| Differential pressure | 13 | |
| Bearing life and external shaft loading | 14 | |
| Mounting flange loads | 15 | |
| Hydraulic unit life | 15 | |
| FEATURES | 16 | System design Parameters |
| High pressure relief valve | 16 | |
| Charge relief valve | 17 | |
| Charge pump | 18 | |
| By-pass | 20 | |
| Displacement limiters | 20 | |
| Mounting flange and shafts | 21 | |
| Auxiliary mounting pad | 22 | |
| Tandem pumps | 24 | |
| Gear pumps | 26 | |
| CONTROLS | 27 | Features |
| Hydraulic servo control | 27 | |
| Electrical on-off servo control | 29 | |
| Electro-proportional servo control | 31 | Controls |
| OPTIONS | 33 | |
| Roller bearing | 33 | Options |
| Customized identification plate | 33 | |
| External inching | 33 | |
| Filter on pressure line | 34 | |
| SAE flange ports | 35 | |
| UNF threads ports | 35 | |
| External connections for filter | 35 | |
| Flushing valve | 36 | |
| Finishing coat | 36 | |

MODEL CODE

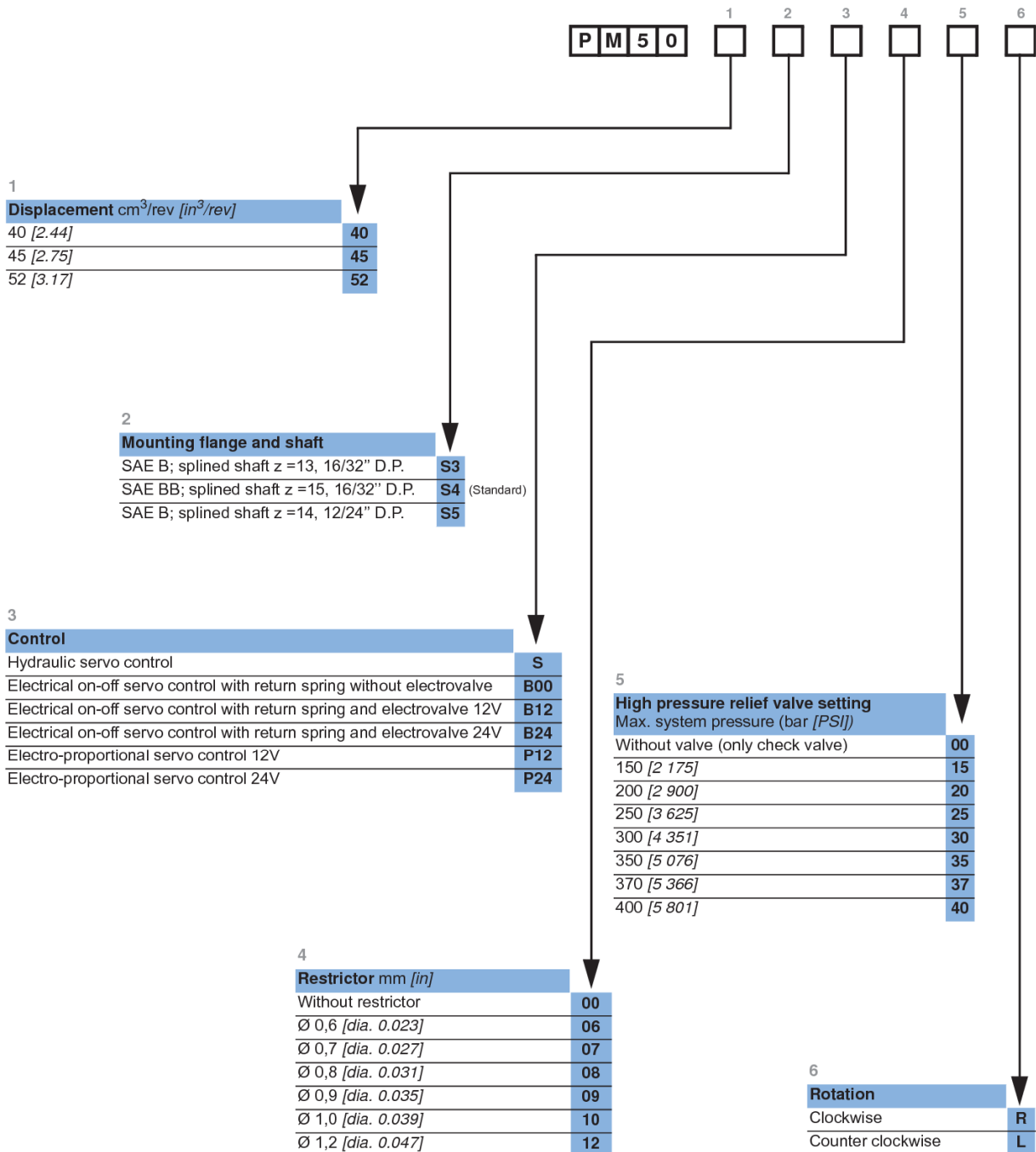

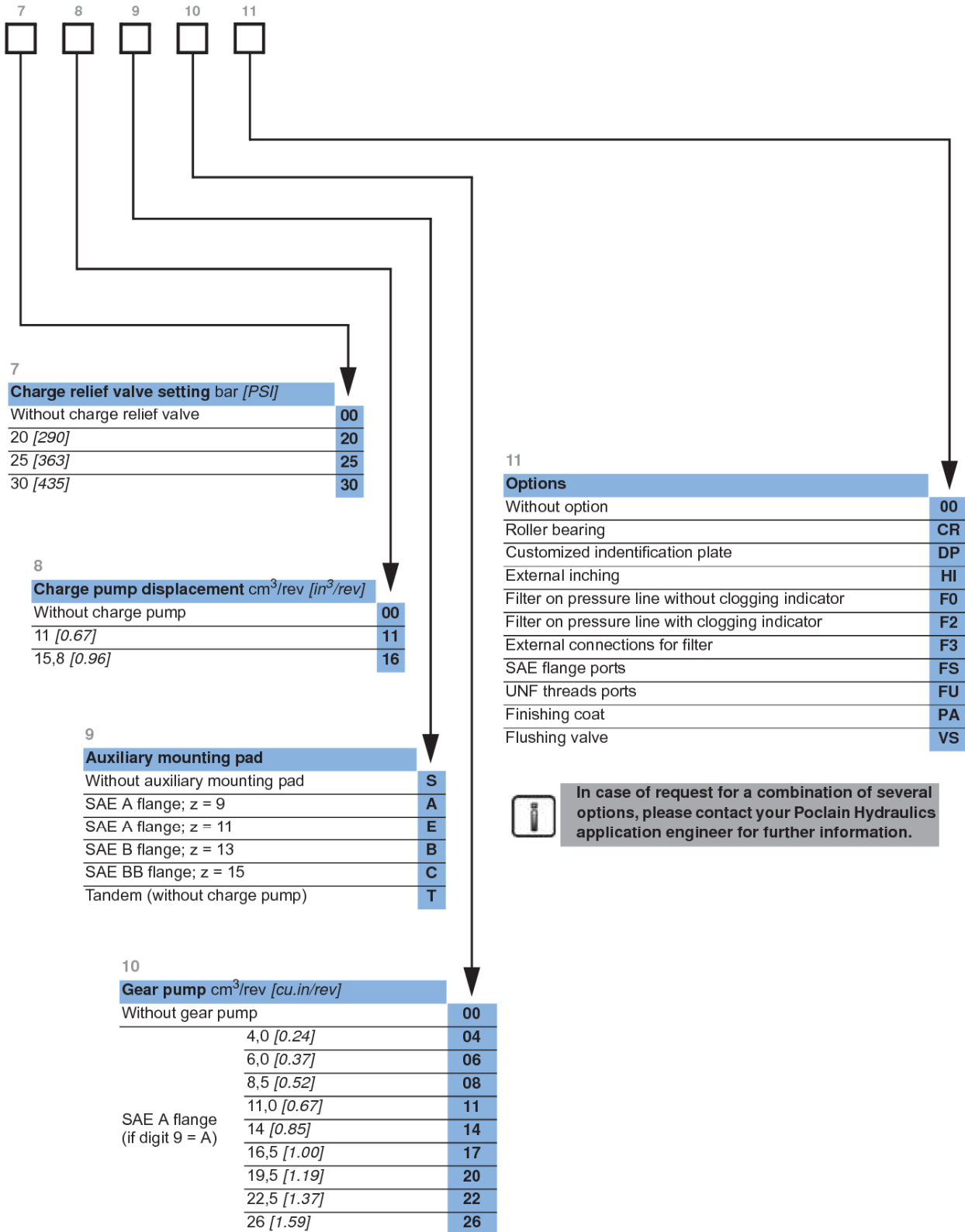

7

| | |
|--|----|
| Charge relief valve setting bar [PSI] | |
| Without charge relief valve | 00 |
| 20 [290] | 20 |
| 25 [363] | 25 |
| 30 [435] | 30 |

8

| | |
|---|----|
| Charge pump displacement cm³/rev [in³/rev] | |
| Without charge pump | 00 |
| 11 [0.67] | 11 |
| 15,8 [0.96] | 16 |

9

| | |
|--------------------------------|---|
| Auxiliary mounting pad | |
| Without auxiliary mounting pad | S |
| SAE A flange; z = 9 | A |
| SAE A flange; z = 11 | E |
| SAE B flange; z = 13 | B |
| SAE BB flange; z = 15 | C |
| Tandem (without charge pump) | T |

10

| | |
|---|----|
| Gear pump cm³/rev [cu.in/rev] | |
| Without gear pump | 00 |
| 4,0 [0.24] | 04 |
| 6,0 [0.37] | 06 |
| 8,5 [0.52] | 08 |
| 11,0 [0.67] | 11 |
| SAE A flange (if digit 9 = A) | |
| 14 [0.85] | 14 |
| 16,5 [1.00] | 17 |
| 19,5 [1.19] | 20 |
| 22,5 [1.37] | 22 |
| 26 [1.59] | 26 |

11

| | |
|--|----|
| Options | |
| Without option | 00 |
| Roller bearing | CR |
| Customized identification plate | DP |
| External inching | HI |
| Filter on pressure line without clogging indicator | F0 |
| Filter on pressure line with clogging indicator | F2 |
| External connections for filter | F3 |
| SAE flange ports | FS |
| UNF threads ports | FU |
| Finishing coat | PA |
| Flushing valve | VS |



In case of request for a combination of several options, please contact your Poclairn Hydraulics application engineer for further information.

TECHNICAL SPECIFICATIONS

Port characteristics

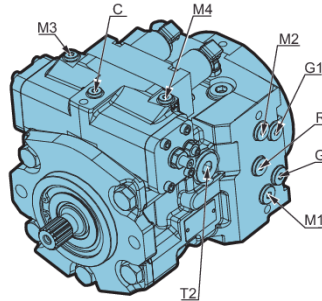
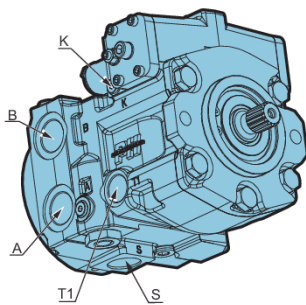

| Port | Function | ISO 1179-1 (standard) |
|-------|---------------------------|--------------------------|
| A/B | Services | 1" GAS |
| C | Case pressure | 1/4" GAS |
| G1/G2 | Auxiliary/Charge pressure | 1/4" GAS |
| M1/M2 | A/B pressure | 1/4" GAS |
| M3/M4 | Servo control | 1/4" GAS |
| K | External servo pilot | 1/8" GAS |
| R | Servo pilot pressure | 1/4" GAS |
| S | Suction | 1" GAS |
| T1/T2 | Drain | 3/4" GAS |

See options FS and FU on page 35 for SAE and UNF port sizes.

Main dimensions

PM50 - SAE BB - splined shaft with hydraulic servo control and without auxiliary mounting pad

| | | | | | | | | | | | |
|----------|----------|----------|----------|---|---|---|---|---|---|----------|----|
| | 1 | 2 | 3 | 4 | 5 | 6 | 7 | 8 | 9 | 10 | 11 |
| P | M | 5 | 0 | | | | | | | S | |

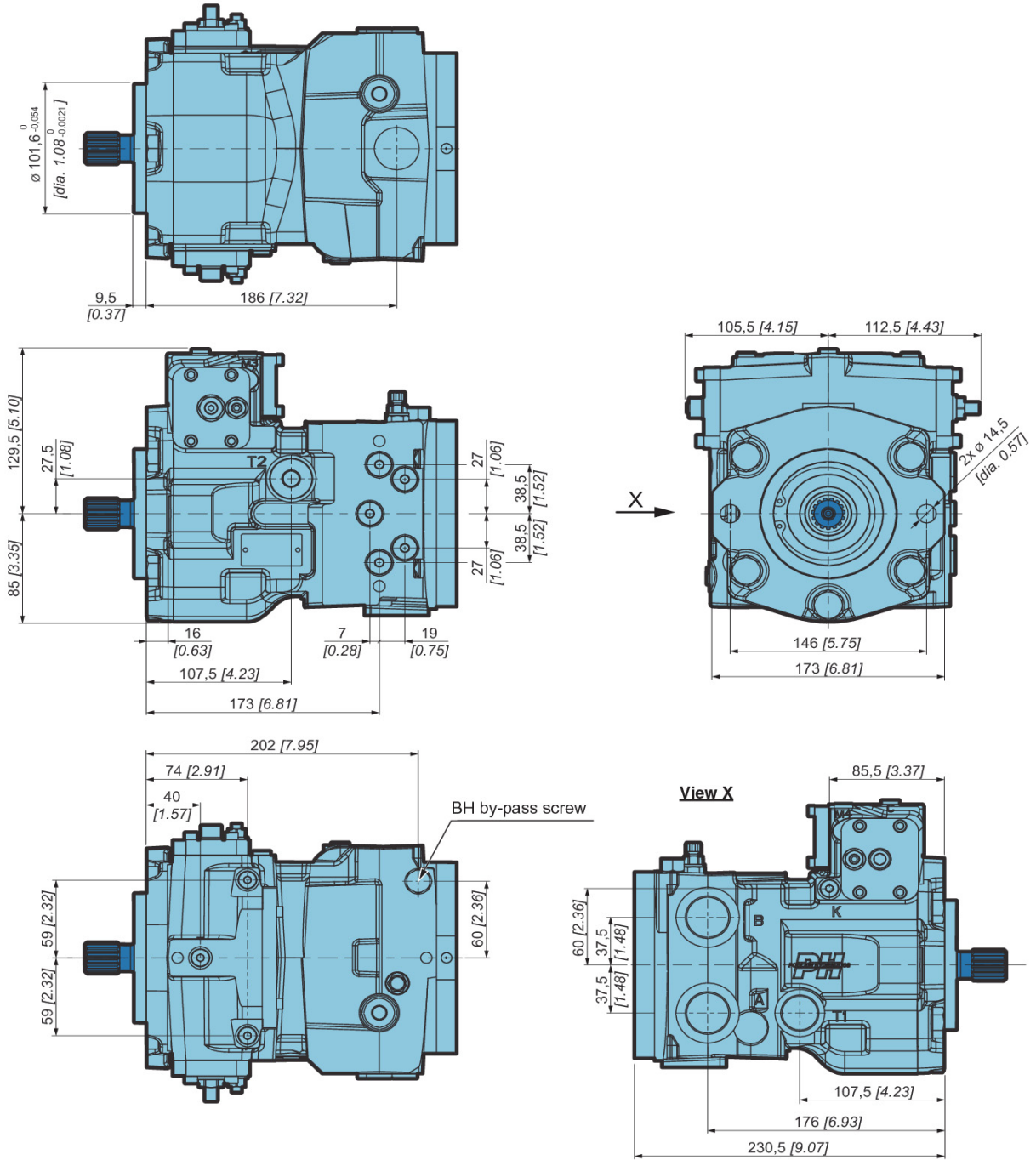

OPERATING PARAMETERS

Operating parameters

| | | PM50-40 | PM50-45 | PM50-52 |
|----------------------------|----------------------|-------------------------|-------------|---------|
| Speed ratings | Minimum | | 700 | |
| | Max. without load | min ⁻¹ (rpm) | 3 600 | |
| | Max. with load | | 3 400 | |
| System pressure | Rated | | 300 [4 351] | |
| | Maximum | bar [PSI] | 400 [5 801] | |
| | Minimum low loop | | 15 [218] | |
| Inlet pressure | Mini continuous | bar (abs.) | 0,8 [11.6] | |
| | Mini (cold start) | [PSI abs.] | 0,5 [7.2] | |
| Case pressure | Continuous | bar [PSI] | 1,5 [21.7] | |
| | Maximum (cold start) | | 2,5 [36.2] | |
| Charge pressure | Standard version | | 25 [362.6] | |
| | Max. charge pressure | bar [PSI] | 30 [435] | |
| Servo case pressure | Maximum | bar [PSI] | 30 [435] | |

Charge pressure

A charge flow is required to maintain a positive pressure in the low pressure loop of a closed loop hydrostatic transmission. Charge pressure ensures proper lubrication and rotating group operation. It is recommended to maintain the charge pressure at a minimum of 15 bar [218 PSI] above case pressure. For more details, refer to charge pump paragraph, page 18.

Case pressure

Case pressure must be maintained within the limits shown in the table "Operating parameters". Ensure housing is always filled with hydraulic fluid and especially during start-up of the machine.

Pressure ratings

Maximum peak pressure

It is the maximum allowable pressure. It is equivalent to the maximum setting of the maximum high pressure relief valve. A self-propelled machine can reach the maximum peak pressure value no more than 1-2% of that work cycle.

Work cycle

A fundamental factor for ensuring correct hydrostatic transmission sizing is the machine work cycle (pressure-time ratio, seasonality, pressure vs. percentage of time at max. displacement, machine type). Part service life depends on the correct choice in relation to the work cycle.

Overloads

It is mandatory to protect parts against any possible overloads.

Speed ratings

The table "Operating parameters" gives minimum and maximum rated speeds. Note that all displacements might operate under different speed limits. Definitions of these speed limits appear below.

Maximum speed is the highest operating speed allowed. Over speeding reduces pump life time, can lead to loss of hydrostatic power and braking capacity. Never exceed the maximum speed limit under any operating conditions.

Nominal speed is the speed offering the maximal efficiency.

Inlet pressure

Charge pump inlet pressure is key for acceptable pump life and performances. A continuous inlet pressure of not less than 0,8 bar abs. [11.6 PSI abs.] is recommended. A continuous inlet pressure less than 0.5 bar abs. [7.2 PSI abs.] indicates inadequate inlet design or a restricted filter. Pressures less than 0.5 bar abs. [7.2 PSI abs.] can happen at cold start, but should increase with oil temperature.

Theoretical output

Theoretical output flow is a function of pump displacement and speed. It is relevant to size the rest of the circuit. Theoretical flow does not take into account losses due to leakage or variations in displacement. Refer to performances, page 6, for volumetric and overall efficiencies at various operating speeds and pressures.

Poclair Hydraulics recommendations for fluid



Poclair hydraulics recommends the use of hydraulic fluids defined by the ISO 12380 and ISO 6743-4 standards.

For temperate climates, the following types are recommended.

- HM 46 or HM 68 for fixed installations.
- HV 46 or HV 68 for mobile installations.
- HEES 46 for mobile installations.

These specifications correspond to category 91H of the CETOP standard, parts 1, 2 and 3 of the DIN 51524 standard, and grades VG32, VG 46 and VG68 of the ISO 6743-4 standards.



It is also possible to use ATF, HD, HFB, HFC or HFD type hydraulic fluid upon Poclair Hydraulics specific approval of the components' operating conditions.

Standardized designations for the fluids

- **HM** : Mineral fluids having specific antioxidant, anticorrosion and antiwear properties (HLP equivalent to DIN 51524 parts 1 and 2).
- **HV** : HM mineral fluids providing improved temperature and viscosity properties (DIN 51524 part 3).
- **HEES** : Biodegradable fluids based on organic esters.



It is also possible to use a fluid that meets the biodegradability criteria and is compatible in the event of accidental food contact. The BIOHYDRAN FG 46 fluid designed by the company Total has undergone testing of its properties and performance on our test benches. Since this type of fluid has not yet been categorized, it is the responsibility of machine manufacturers to validate its compatibility with all of the components used in order to guarantee that the intended functions will be fulfilled and this for the desired life time of all equipment items.



For biodegradable fluids, consult your Poclair Hydraulics' application engineer



During operation, the temperature of the oil must be between 0°C [32°F] and 80°C [176°F]; the minimum and maximum temperatures may be exceeded momentarily by ± 20°C [± 68°F] for a duration of less than 30 minutes. For all applications outside these limits, please consult with your Poclair Hydraulics' application engineer.

Fluid and filtration

The contaminating particles suspended in the hydraulic fluid cause the hydraulic mechanisms moving part wear. On hydraulic pumps, these parts operate with very small dimensional tolerances. In order to reach the part life, it is recommended to use a filter that maintains the hydraulic fluid contamination class at a max. of:

- 9 according to NAS 1638
- 20/18/15 according to ISO 4406:1999

According to the type of application decided for the pump, it is necessary to use filtration elements with a filtration ratio of:

$$\beta_{20 \text{ to } 30} \geq 100$$

Making sure that this ratio does not worsen together with the increasing of the filter cartridge differential pressure.

If these values cannot be observed, the component life will consequently be reduced and it is recommended to contact the Poclair Hydraulics Customer Service.

Filters on charge circuit

Filters on the charge circuit (F0-F2) are designed without by-pass. The max. pressure drop on the filtration part must not exceed 2 bar [29 PSI] (3 bar [43.5 PSI] in case of cold starting) at pump full rating. To monitor the pressure drop, it is recommended to use the clogging indicator on the filtration element (F2 option). Contact your Poclair Hydraulics Application engineer, each time the pump is not charged by its internal charge pump. Filters on charge circuit are mounted on the pump special support.

Filters assembling

The suction filter is mounted on the suction line. Check that the pressure before the charge pump is 0.8 bar abs. [11.6 PSI abs.], measured on the pump suction port (0.5 bar [7.2 PSI] for cold starting).

Viscosity range

For both max. efficiency and life of the unit, the operative viscosity should be chosen within the optimum range of:
 $\sqrt{\text{opt}}$ = optimum operating viscosity from 16 to 36 mm²/s [from 74.1 to 166.8 SUS] referred to the closed loop temperature.

Working conditions: the following limits of viscosity apply

- $\sqrt{\text{min}}$ = 5 mm²/s [23 SUS] short-duration at a max. permissible leakage oil temperature of 90° C [194 °F]
- $\sqrt{\text{max}}$ = 1000 mm²/s [4 634 SUS] short-duration, on cold start.

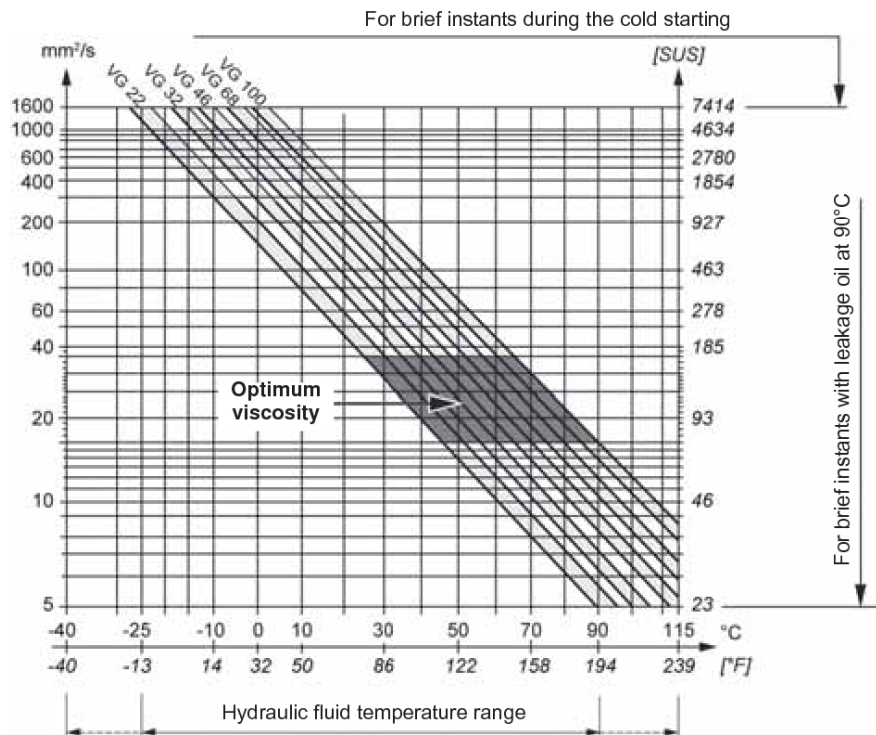

Ensure fluid temperature and viscosity limits are concurrently satisfied.



SYSTEM DESIGN PARAMETERS



Consult your Poclairn Hydraulics application engineer to validate your design parameters before using the pump in your application.

Sizing equations

The following equations are helpful when sizing hydraulic pumps. Generally, the sizing process is initiated by an evaluation of the machine system to determine the required motor speed and torque to perform the necessary work function. First, the motor is sized to transmit the maximum required torque. The pump is then selected as a flow source to achieve the maximum motor speed.

| | | | |
|-----------------|-----------------------|---|----------|
| | Output flow Q | = $\frac{V_g \cdot n \cdot \eta_v}{1000}$ | (l/min) |
| SI units | Input torque M | = $\frac{V_g \cdot \Delta p}{20 \cdot \pi \cdot \eta_m}$ | (N.m) |
| | Input power P | = $\frac{M \cdot n \cdot \pi}{30\,000} = \frac{Q \cdot \Delta p}{600 \cdot \eta_t}$ | (kW) |
| | Output flow Q | = $\frac{V_g \cdot n \cdot \eta_v}{231}$ | [GPM] |
| US units | Input torque M | = $\frac{V_g \cdot \Delta p}{2 \cdot \pi \cdot \eta_m}$ | [lbf.in] |
| | Input power P | = $\frac{M \cdot n \cdot \pi}{198\,000} = \frac{Q \cdot \Delta p}{1714 \cdot \eta_t}$ | [hp] |

V_g = Displacement per revolution cm^3/tr [in^3/rev]
 Δp = $p_o - p_i$ (system pressure) bar [PSI]
 n = Speed min^{-1} [rpm]
 η_v = Volumetric efficiency
 η_m = Mechanical efficiency
 η_t = Overall efficiency ($\eta_v \cdot \eta_m$)

Redundant braking system requirement



Unintended vehicle or machine movement hazard.
 The loss of hydrostatic drive line power, in any mode of operation (forward, neutral, or reverse) may cause the system to lose hydrostatic braking capacity. You must provide a braking system, redundant to the hydrostatic transmission, sufficient to stop and hold the vehicle or machine in the event of hydrostatic drive power loss.

Loop flushing

Closed circuit may require a flushing valve to meet temperature and cleanliness requirements. A flushing valve takes a part of hot fluid flow from the low pressure loop of the system loop for cooling and filtering. Make sure that the charge pump provides adequate flow for the flushing valve flushing and the flushing valve does not cause charge pressure to drop below recommended limits.

See option VS page 36 for more information.

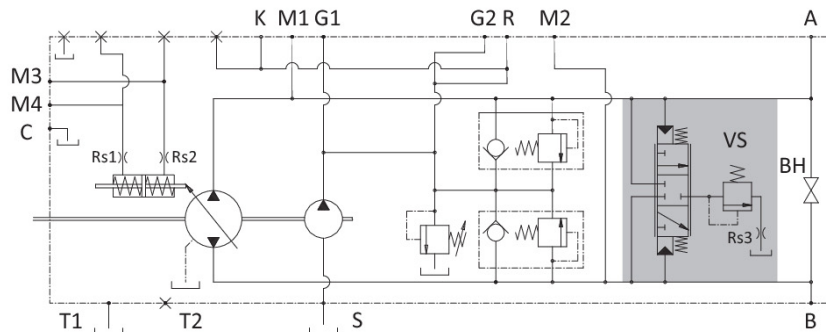

Reservoir

The reservoir provides clean fluid, dissipates heat, and removes entrained air from the hydraulic fluid. It allows for fluid volume changes associated with fluid expansion and cylinder differential volumes. Minimum reservoir capacity depends on the volume needed to perform these functions. Typically, a capacity of one half the charge pump flow (per minute) is satisfactory for a closed reservoir. Open circuit systems sharing a common reservoir require greater fluid capacity.

Locate the reservoir outlet (suction line) near the bottom, allowing clearance for settling foreign particles. Use a 100 - 125 µm screen covering the outlet port.

Place the reservoir inlet (return lines) below the lowest expected fluid level, as far away from the outlet as possible.

Use a baffle (or baffles) between the reservoir inlet and outlet ports to promote de-aeration and reduce fluid surging.

Case drain usage for tandem pump

To ensure lubrication of both pumps (with only one charge pump), excess flow from the second pump charge relief valve must be routed into the housing of the first pump.



Tandem pumps with the option of opposing port endcaps do not follow the above rule.

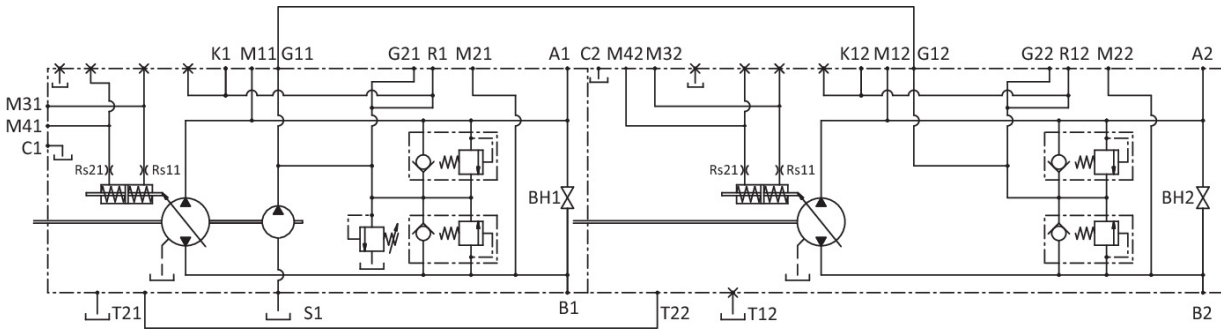

Differential pressure

The differential pressure is the High pressure relief valve setting minus Charge relief valve setting.

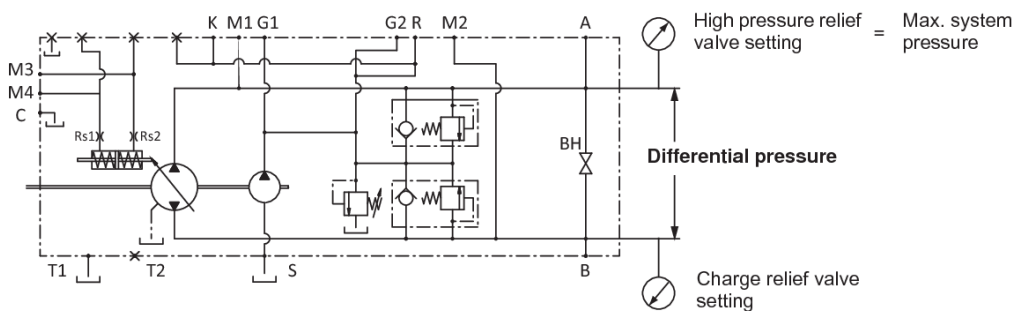

Bearing life and external shaft loading

Bearing life:

Bearing life is a function of speed, pressure, swashplate angle and external loads. Oil type and viscosity impact bearing life..

| Ball bearing life (B ₁₀ hours) | |
|---|--------|
| PM50-40 | 21 000 |
| PM50-45 | 14 500 |
| PM50-52 | 9 500 |

Shaft Loads

Normal bearing life in B₁₀ hours is shown in the above table. Figures have been calculated under the following operating conditions : A continuous differential pressure of 150 bar [2 176PSI], 1 800 rpm shaft speed, maximum displacement, without any external shaft side load. The data is based on a 50% forward, 50% reverse duty cycle, standard charge pump size, and standard charge pressure.

PM50 pumps are designed with bearings that can accept external radial and thrust loads. The external radial shaft load limits depend on the load position, orientation, and operating conditions of the unit.

The maximum permissible radial load (Re), is based on the maximum external moment (Me), and the distance (L) from the mounting flange to the load. It may be determined using the table and formula below. Thrust (axial) load limits are also shown.

$$Re = Me / L$$

All external shaft loads affect bearing life. In applications with external shaft loads, minimize the impact by positioning the load at 90° or 270° as shown in the figure.

Contact your Poclairn Hydraulics representative for an evaluation of unit bearing life if:

- Continuously applied external loads exceed 25 % of the maximum allowable radial load Re.
- The pump swashplate is positioned on one side of center all or most of the time.
- The unit bearing life (B₁₀) is critical.

| | External moment (Me) | Maximum shaft thrust |
|---------|---|--|
| | N.m [in.lbf] (Based on shaft deflection) | N [lbf] (at ΔP 180 bar [2 611 PSI] and 3 400 rpm) |
| PM50-40 | 150 [1 328] | 1 500 [337] |
| PM50-45 | 107 [947] | 1 500 [337] |
| PM50-52 | 76 [673] | 1 500 [337] |

Radial and thrust load position

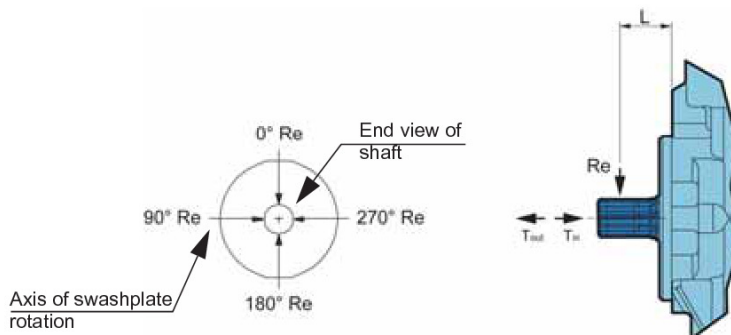

For an accurate calculation, consult your Poclairn Hydraulics application engineer.

Hydraulic unit life

Hydraulic unit life is the life expectancy of the hydraulic components. It depends on speed and system pressure even if , system pressure is the dominant operating variable. High pressure, generated by high load, reduces hydraulic unit life.

Design the hydraulic system according to the expected machine duty cycle. Take in consideration the expected percentages of time at various loads and speeds. Ask your Poclain Hydraulics representative to calculate an appropriate pressure based your hydraulic system design. If duty cycle data is not available, input power and pump displacement are used to calculate system pressure.

All pressure limits are differential pressures (referenced to charge pressure) , taking a normal charge pressure in consideration.

PM50 pumps will meet satisfactory life expectancy if applied within the parameters specified in this technical documentation. For more detailed information on hydraulic unit life see Operating Parameters in page 9.

Mounting flange loads

Adding tandem mounted pumps, and/or tandem auxillary pump(s), subjecting pumps to shock loads may generate excessive loads on the front mounting flange. The overhung load moment for multiple pump mounting can be estimated as shown in the figure below

Overhung load example

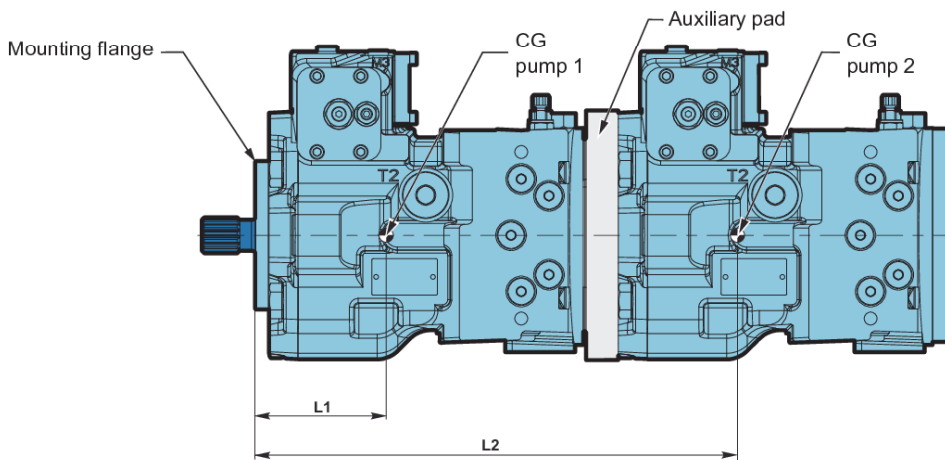

For two PM50 in tandem the approximate distances (exact values depend on pumps configuration) of gravity centers from front mounting flange are:

- L1 = 92 mm [3.62 inch]
- L2 = 330 mm [12.99 inch]

Estimating overhung load moments

- W = Weight of pump (kg)
- L = Distance from mounting flange to pump center of gravity (CG)
- $M_R = G_R (W_1L_1 + W_2L_2 + \dots + W_nL_n)$
- $M_S = G_S (W_1L_1 + W_2L_2 + \dots + W_nL_n)$

Where:

- M_R = Rated load moment (N.m)
- M_S = Shock load moment (N.m)
- G_R^* = Rated (vibratory) acceleration (G's) (m/sec²)
- G_S^* = Maximum shock acceleration (G's) (m/sec²)

*Calculations will be carried out by multiplying the gravity (g = 9.81 m/sec²) with a given factor. This factor depends on the application.

Allowable overhung load moment are shown in the above table. Exceeding these values requires additional pump support.

| | Rated moment (MR) | Shock load moment (MS) |
|---------|-------------------|------------------------|
| | N.m [in.lbf] | N.m [in.lbf] |
| PM50-40 | 900 [7 966] | 2 000 [17 701] |
| PM50-45 | 900 [7 966] | 2 000 [17 701] |
| PM50-52 | 900 [7 966] | 2 000 [17 701] |



For an accurate values and calculations, consult your Poclain Hydraulics application engineer.

FEATURES

High pressure relief valve

The High pressure relief valves maintain circuit pressure in the proper range. The check valves allow charge flow to replenish the low pressure loop of the circuit. The high pressure relief valves ensure a high pressure protection of the high pressure loop of the circuit.

High pressure relief valves are available in a large range of settings. They are not adjustable.

When high pressure relief valves are not desired, pumps may be equipped with charge circuit check valves only.



High pressure relief valves are intended for transient overpressure protection and are not intended for continuous pressure control. Flow over relief valves for extended periods of time may result in severe heat build up. High flows over relief valves may result in pressure levels exceeding the nominal valve setting and potential damage to system components.



| High pressure relief valve | Available setting bar [PSI] | |
|----------------------------|-----------------------------|----|
| Without | - | 00 |
| | 150 [2 175] | 15 |
| | 200 [2 900] | 20 |
| With | 250 [3 625] | 25 |
| | 300 [4 351] | 30 |
| | 350 [5 076] | 35 |
| | 370 [5 366] | 37 |
| | 400 [5 801] | 40 |

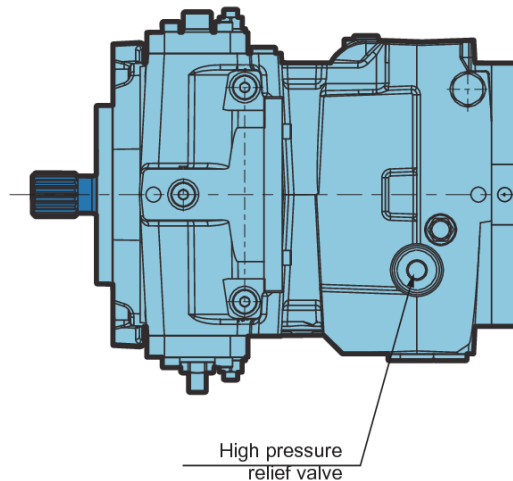
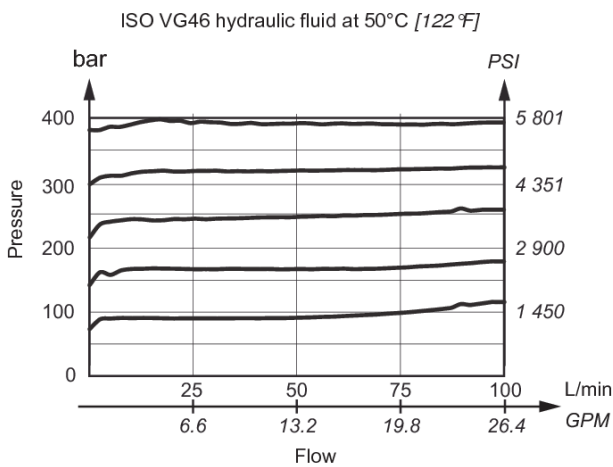
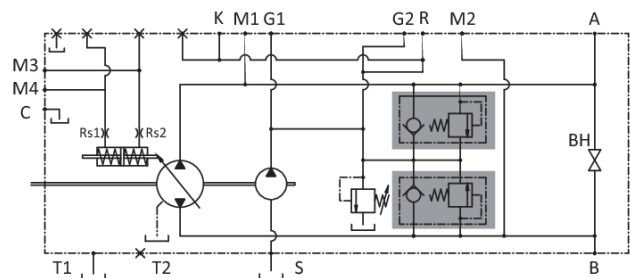

Charge relief valve

The charge pressure relief valve provides a relief outlet for charge circuit. This valve is used to set the charge pressure of the circuit. Flow through the valve is ported to case.

The nominal charge relief setting is referenced to case pressure.



Incorrect charge pressure settings may result in the inability to build required system pressure and/or inadequate loop flushing flows. Ensure correct charge pressure under all conditions of operation to maintain pump control performance.



| Charge relief valve | Available setting bar [PSI] | |
|---------------------|--------------------------------|----|
| Without | - | 00 |
| With | 20 [290] | 20 |
| With (standard) | 25 [363] | 25 |
| With | 30 [435] | 30 |

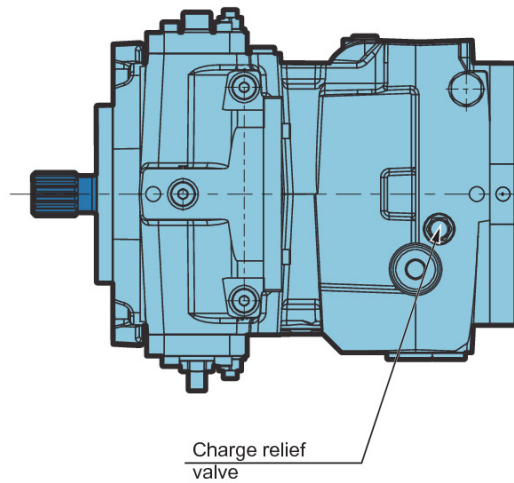
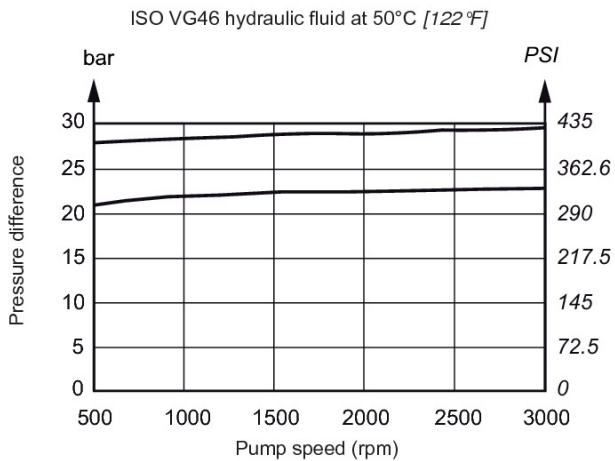
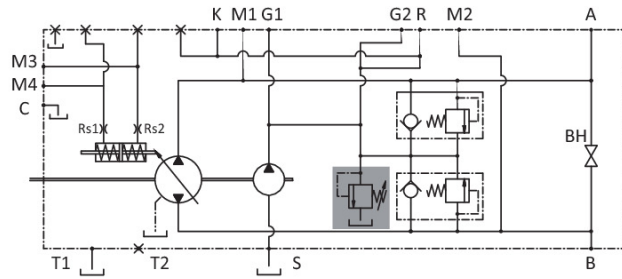

Charge pump

Charge flow is required on all PM50 pumps used in closed circuit installations. The charge pump provides flow to make up internal leakage, maintain a positive pressure in the main circuit, provide flow for cooling and filtration, replace any leakage losses from external valving or auxiliary systems, and to provide flow and pressure for the control system.

Many factors influence the charge flow requirements. These factors include system pressure, pump speed, pump swashplate angle, type of fluid, temperature, size of heat exchanger, length and size of hydraulic lines, control response characteristics, auxiliary flow requirements, hydrostatic motor type, etc.

Unusual application conditions may require a more detailed review of charge pump sizing. Charge pressure must be maintained at a specified level under all operating conditions to prevent damage to the transmission. Poclairn Hydraulics recommends testing under actual operating conditions to verify this.

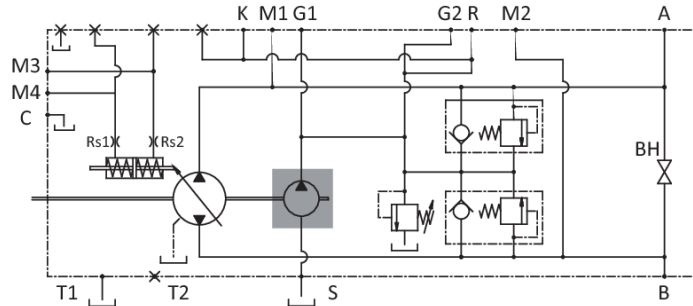

Charge pump sizing / selection

In most applications a general guideline is that the charge pump displacement should be at least 20% of the main pump displacement.

| Charge pump | Displacement cm ³ /rev [in ³ /rev] | Rated speed (rpm) | |
|-------------|---|----------------------|----|
| Without | - | - | 00 |
| With | 11 [0.67] | 3600 | 11 |
| | 15,8 [0.96] | 3600 | 16 |



Contact your Poclairn Hydraulics application engineer for more information.

Without charge pump



The external charge flow must be the same that the internal charge pump flow.

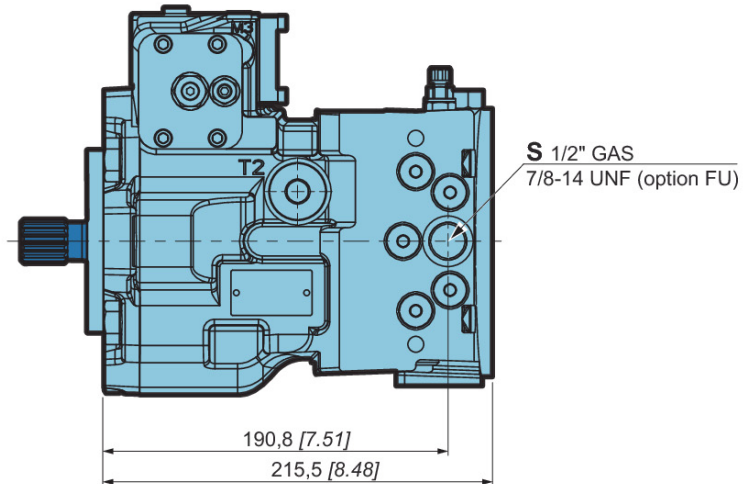
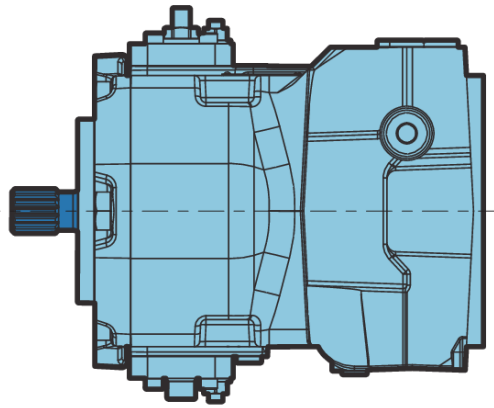
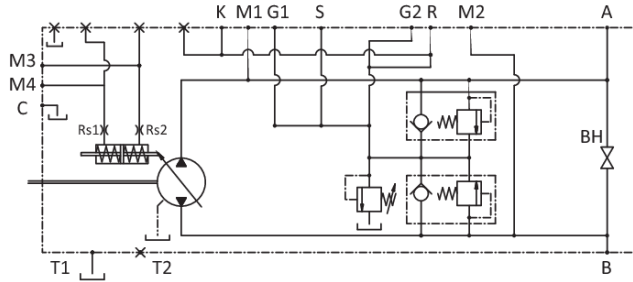

Displacement limiters

PM50 are designed with mechanical displacement (stroke) limiters. You can limit maximum displacement of the pump to a certain per-cent of its maximum displacement to near zero in both direction.

The displacement limiters are located on the both sides of the servo piston and are adjustable by screw.



Take care in adjusting displacement limiters to avoid an undesirable condition of output flow or speed. Retorque the sealing lock nut after every adjustment to prevent an unexpected change in output conditions and to prevent external leakage during pump operation.

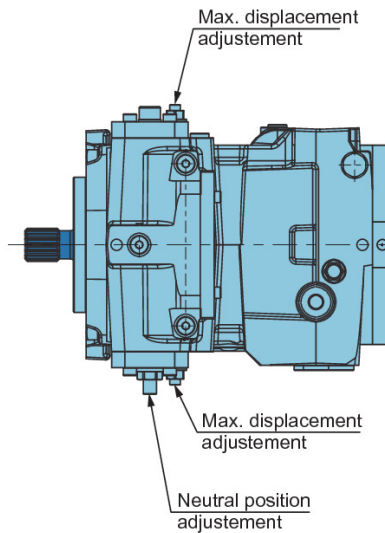

By-pass

PM50 features a by-pass function. By-passing Port A and Port B is achieved by unscrewing a screw located on the cover. The by-pass connect the ports A-B and must be use only in emergency case and only for short movement.

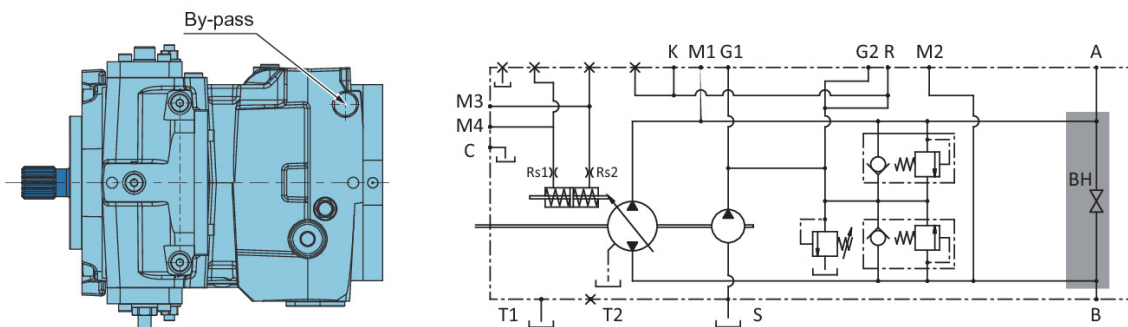

To avoid leakage, do NOT exceed two turns of the screw.



By-pass valve is intended for moving a machine for very short distances at very slow speeds. It is NOT intended as tow valve.

Mounting flange and shafts



S3 SAE B - Splined shaft

13 teeth; Max. torque: 220 Nm [1947 in.lbf]

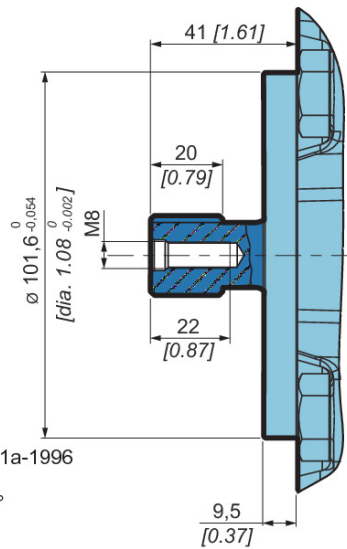

Splined ANSI B92.1a-1996
Pitch 16/32° DP
Pressure angle 30°
Tolerance class: 5

S4 SAE BB - Splined shaft (standard)

15 teeth; Max. torque: 360 Nm [3186 in.lbf]

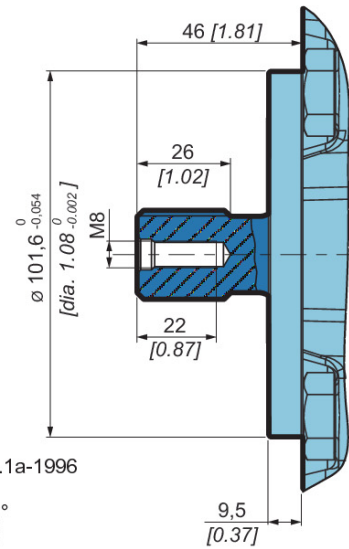

Splined ANSI B92.1a-1996
Pitch 16/32° DP
Pressure angle 30°
Tolerance class: 5

S5 SAE B - Splined shaft

14 teeth; Max. torque: 600 Nm [5310 in.lbf]

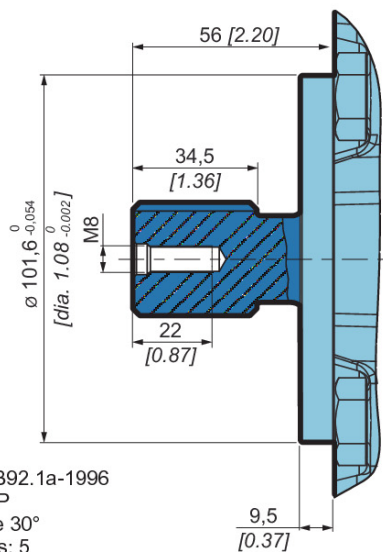

Splined ANSI B92.1a-1996
Pitch 12/24° DP
Pressure angle 30°
Tolerance class: 5

Auxiliary mounting pad

SAE A flanges

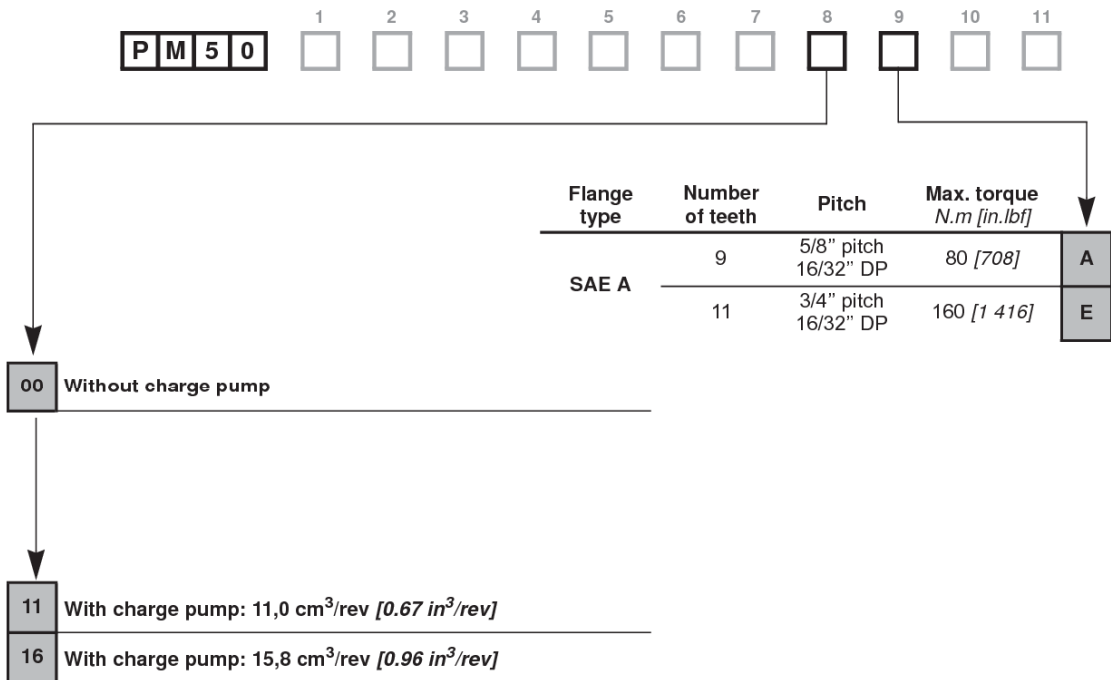

Splined ANSI B92.1a-1996
Pressure angle 30°
Tolerance class: 5

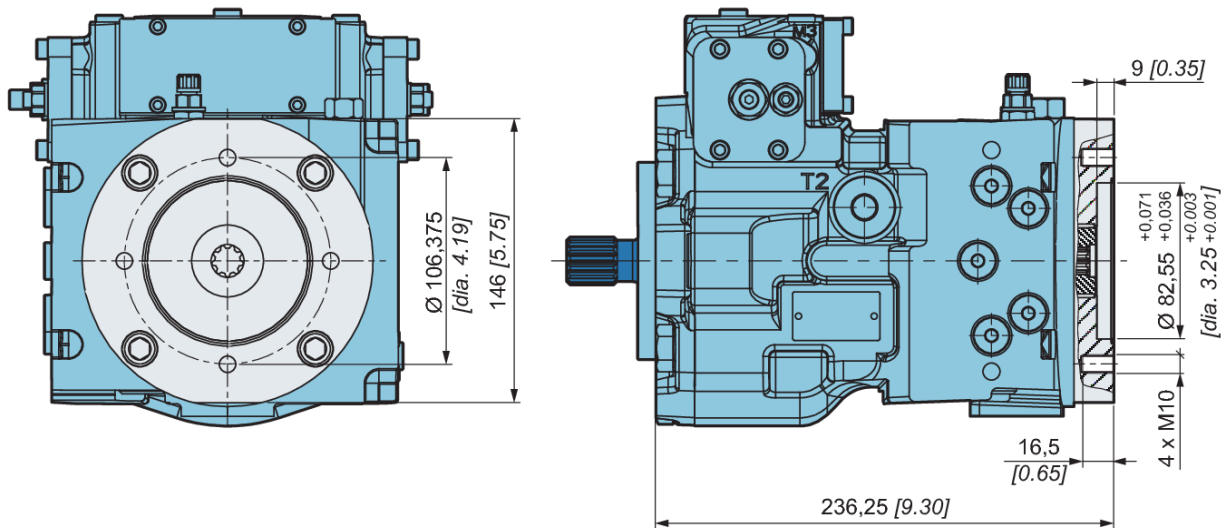

Do not rotate the thru shaft cover.

SAE-B and SAE-BB flanges



| Flange type | Number of teeth | Pitch | Max. torque N.m [in.lbf] | |
|-------------|-----------------|-------------------------|-----------------------------|---|
| SAE B | 13 | 7/8" pitch 16/32" DP | 230 [2 036] | B |
| SAE BB | 15 | 1" pitch 16/32" DP | 360 [3 186] | C |

- 00 Without charge pump

- 11 With charge pump: 11,0 cm³/rev [0.67 in³/rev]

- 16 With charge pump: 15,8 cm³/rev [0.96 in³/rev]

Splined ANSI B92.1a-1996
Pressure angle 30°
Tolerance class: 5

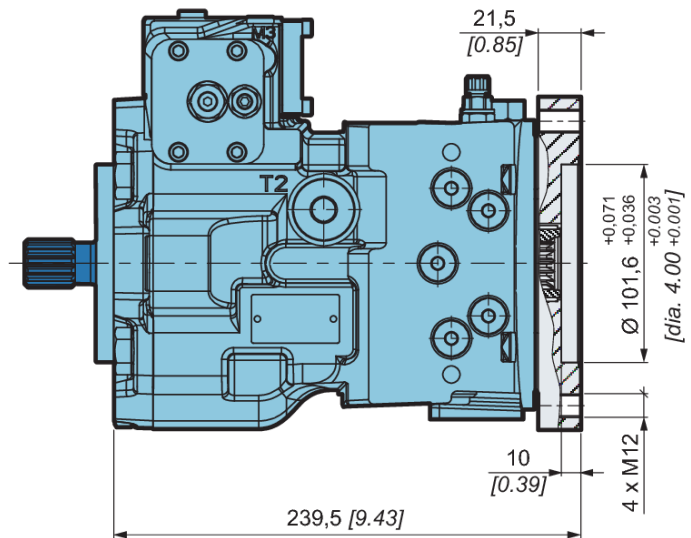
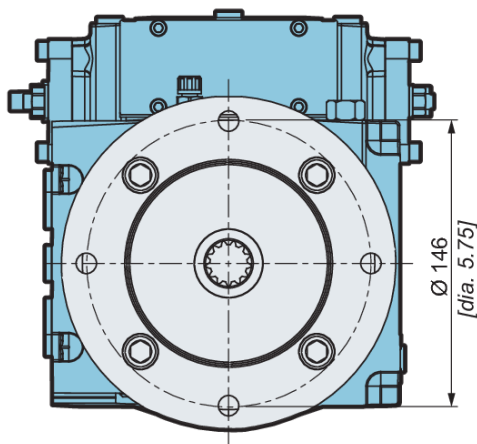

Do not rotate the thru shaft cover.

Tandem pumps

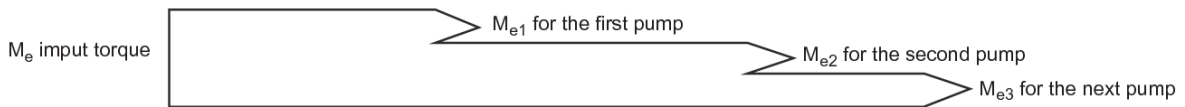
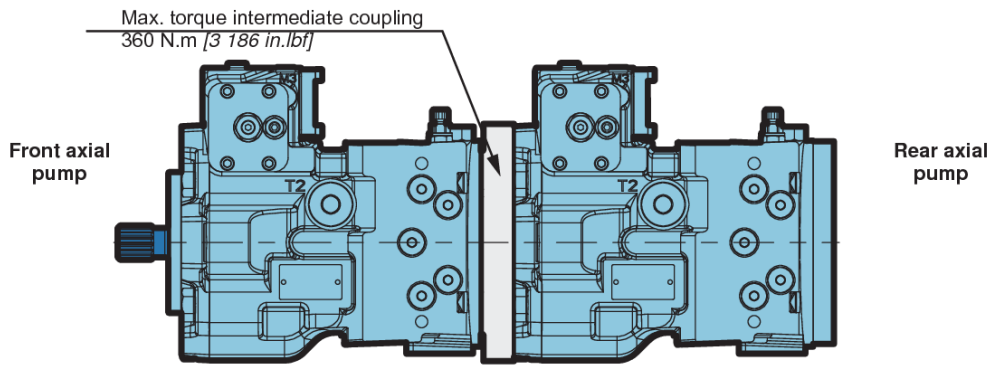

Torque required by auxiliary pumps is additive. Ensure requirements don't exceed shaft torque ratings.



| Number of charge pump in the tandem | Axial pump | Mounting flange and shaft | | Charge pump | Auxiliary mounting flange | Total axial length mm [inch] | | |
|-------------------------------------|------------|---------------------------|----|-------------|---------------------------|------------------------------|---|---------------|
| | | SAE BB; 15 teeth | S4 | | | | | |
| 0 charge pump | Front | SAE BB; 15 teeth | S4 | Without | 00 | Tandem fitting | | |
| | | SAE B; 14 teeth | S5 | | | | | |
| | Rear | SAE BB; 15 teeth | S4 | Without | 00 | Without fitting | S | 455,0 [17.91] |
| | | | | | | SAE A; 9 teeth | A | 475,8 [18.73] |
| | | | | | | SAE A; 11 teeth | E | 475,8 [18.73] |
| | | | | | | SAE B; 13 teeth | B | 479 [18.86] |
| SAE BB; 15 teeth | C | 479 [18.86] | | | | | | |
| 1 charge pump | Front | SAE BB; 15 teeth | S4 | With | 11 or 16 | Tandem fitting | | |
| | | SAE B; 14 teeth | S5 | | | | | |
| | Rear | SAE BB; 15 teeth | S4 | Without | 00 | Without fitting | S | 455,0 [17.91] |
| | | | | | | SAE A; 9 teeth | A | 475,8 [18.73] |
| | | | | | | SAE A; 11 teeth | E | 475,8 [18.73] |
| | | | | | | SAE B; 13 teeth | B | 479 [18.86] |
| SAE BB; 15 teeth | C | 479 [18.86] | | | | | | |
| 2 charge pumps | Front | SAE BB; 15 teeth | S4 | With | 11 or 16 | SAE BB; 15 teeth | C | |
| | | SAE B; 14 teeth | S5 | | | | | |
| | Rear | SAE BB; 15 teeth | S4 | With | 11 or 16 | Without fitting | S | 470 [17.91] |
| | | | | | | SAE A; 9 teeth | A | 475,8 [18.73] |
| | | | | | | SAE A; 11 teeth | E | 475,8 [18.73] |
| | | | | | | SAE B; 13 teeth | B | 479 [18.86] |
| SAE BB; 15 teeth | C | 479 [18.86] | | | | | | |



Gear pumps are always delivered flanged on the axial pump. They can not be sold alone.

Example of tandem configuration with 1 charge pump

| | | | | | | | | | | | | |
|-------------------|----------------|--------------------------|-----------|--------------------------|--------------------------|--------------------------|--------------------------|--------------------------|--------------------------|----------|--------------------------|--------------------------|
| Front axial pump | P M 5 0 | 1 | 2 | 3 | 4 | 5 | 6 | 7 | 8 | 9 | 10 | 11 |
| | | <input type="checkbox"/> | S4 | <input type="checkbox"/> | <input type="checkbox"/> | <input type="checkbox"/> | <input type="checkbox"/> | <input type="checkbox"/> | <input type="checkbox"/> | T | <input type="checkbox"/> | <input type="checkbox"/> |
| Rear axial pump + | P M 5 0 | | S4 | <input type="checkbox"/> | <input type="checkbox"/> | <input type="checkbox"/> | <input type="checkbox"/> | <input type="checkbox"/> | 00 | S | <input type="checkbox"/> | <input type="checkbox"/> |

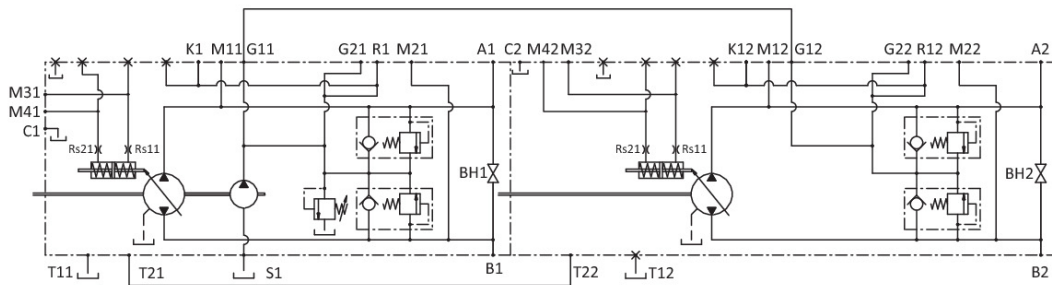
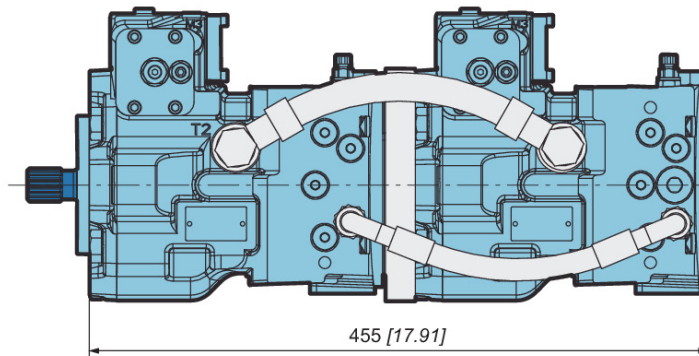

 Ports T and G of the first pump must be connected with ports T and G of the second pump.

Example of tandem configuration with 2 charge pumps

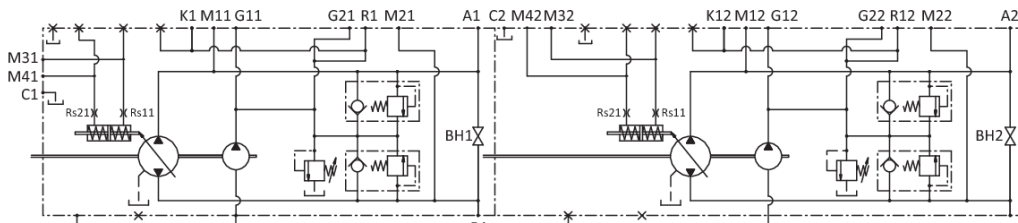
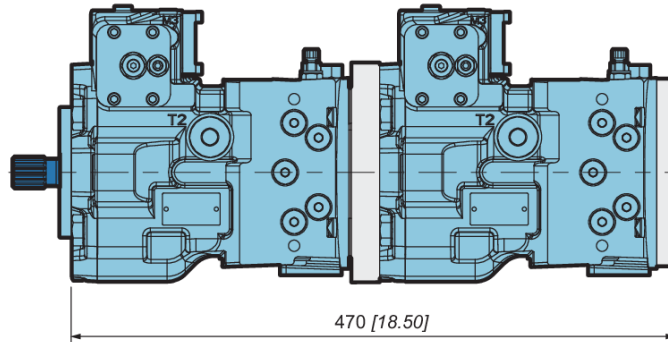

Gear pumps

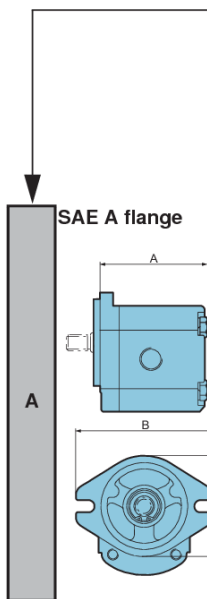

| | Displacement cm ³ /rev [cu.in/rev] | Pressure | | | Dimension | | | Mass Kg [lb] | Efficiency % |
|-----------|---|---------------------------------------|---|---------------------------------|-----------------|-----------------|--------------|-----------------|-----------------|
| | | Continuous max. pressure bar [PSI] | Max. intermittent pressure bar [PSI] | Max. peak pressure bar [PSI] | A mm [in] | B mm [in] | C mm [in] | | |
| 04 | 4,0 [0.24] | 250 [3 625] | 270 [3 915] | 290 [4 205] | 93 [3.66] | | | 2,30 [5.07] | |
| 06 | 6,0 [0.37] | 250 [3 625] | 270 [3 915] | 290 [4 205] | 96,3 [3.79] | | | 2,45 [5.40] | |
| 08 | 8,5 [0.52] | 250 [3 625] | 270 [3 915] | 290 [4 205] | 100,5 [3.96] | | | 2,60 [5.73] | |
| 11 | 11,0 [0.67] | 250 [3 625] | 270 [3 915] | 290 [4 205] | 104,6 [4.12] | | | 2,70 [5.95] | |
| 14 | 14 [0.85] | 250 [3 625] | 270 [3 915] | 290 [4 205] | 109,6 [4.31] | 130,4 [5.13] | 95 [3.74] | 2,80 [6.17] | 95* |
| 17 | 16,5 [1.00] | 230 [3 335] | 240 [3 480] | 250 [3 625] | 113,8 [4.48] | | | 2,95 [6.51] | |
| 20 | 19,5 [1.19] | 210 [3 045] | 220 [3 190] | 230 [3 335] | 118,8 [4.68] | | | 3,10 [6.84] | |
| 23 | 22,5 [1.37] | 190 [2 755] | 200 [2 900] | 210 [3 045] | 123,8 [4.87] | | | 3,25 [7.17] | |
| 26 | 26 [1.59] | 170 [2 465] | 180 [2 610] | 190 [2 755] | 129,6 [5.10] | | | 3,40 [7.50] | |

* Value collected during the testing at 1500 rpm

CONTROLS

Hydraulic servo control



The variation in pump displacement is obtained by adjusting the pressure on the M3 and M4 servo control connections by means of a hydraulic proportional joystick (containing pressure reduction valves).

The joystick supply can be obtained by taking pressure from the auxiliary pump (G connection).

The servo control response time can be adjusted by inserting a restrictor (Rs1 and Rs2) on the joystick supply line (from 0,6 to 1,2 mm [from 0.02 to 0.05 in]).

The servo control operation curve in both control directions goes from 4,5 to 15 bar [from 65 to 218 PSI]. The adjustment curve of the hydraulic control system has to be wider (from 4 to 16 bar [from 58 to 232 PSI]).

Flow rate determination

| Rotation | M3 | M4 |
|-------------------------|----|----|
| Clockwise (CW) | A | B |
| Counter clockwise (CCW) | B | A |

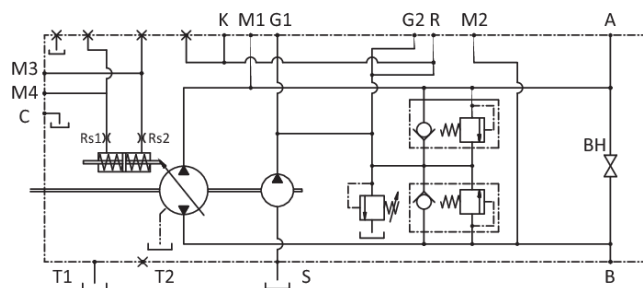

Servo pressure vs Displacement

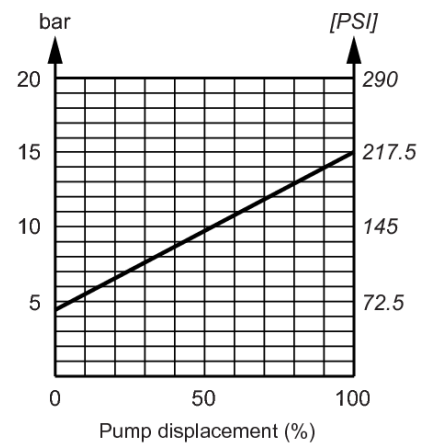

The spring return feature in the control unit is not a safety device.

Dimensions

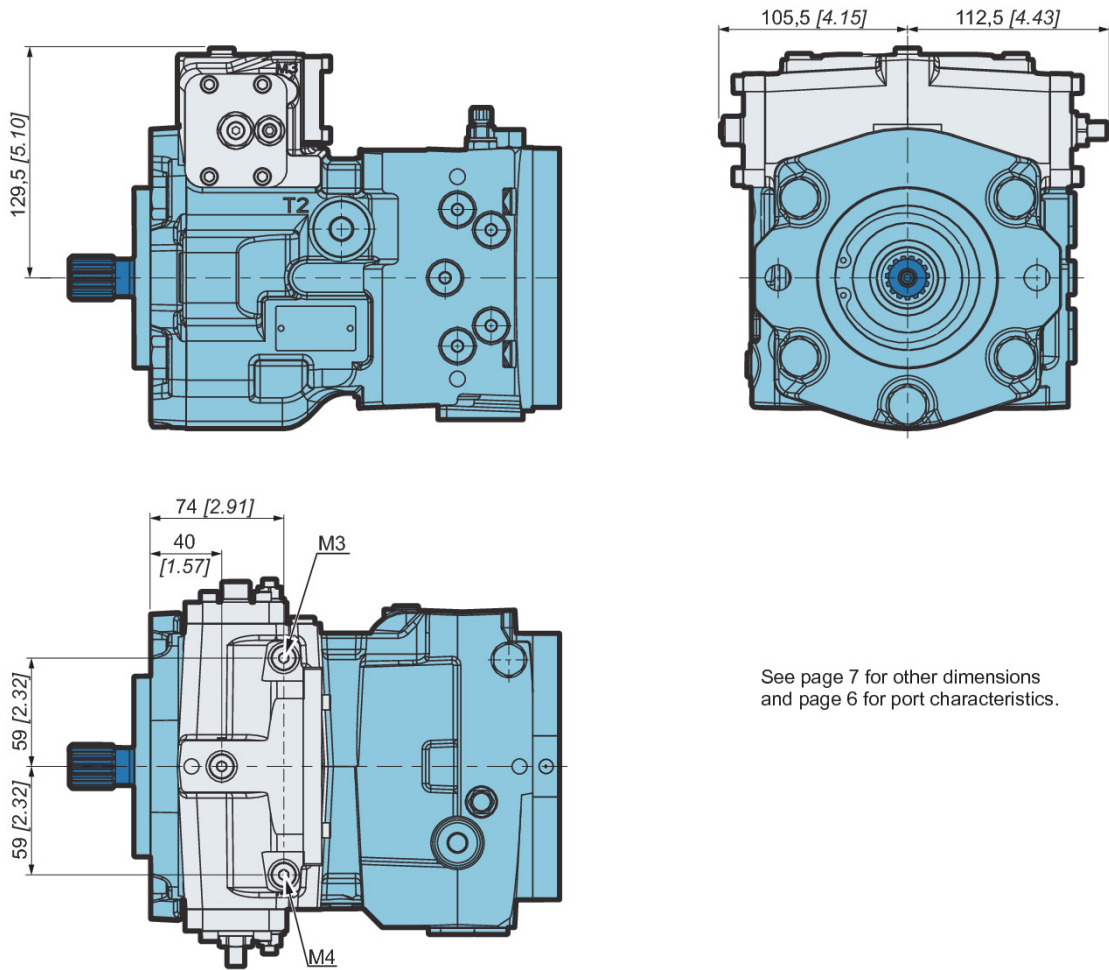

See page 7 for other dimensions
and page 6 for port characteristics.

Electrical on-off servo control

Control with return spring



Maximum displacement is reached by the continuous power (Ev1 or Ev2) of an On-Off electrovalve with an open-circuit CETOP 2 ports. Time to reach the maximum displacement is defined by restrictors Rs1 & Rs2.

If the electro-valve motion is stopped, the pump goes back to "0" position thanks to the servo control springs.

The pump can be supplied either without electrovalve (B00) or with electrovalve (B12, B24).

| Supply voltage | |
|----------------|------------|
| without | B00 |
| 12V | B12 |
| 24V | B24 |

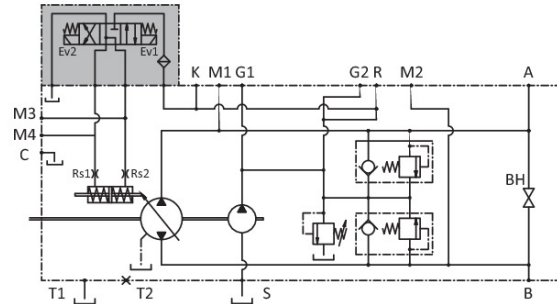

The center of the on-off electrovalve is open

Flow rate determination

| Rotation | EV1 | EV2 |
|-------------------------|-----|-----|
| Clockwise (CW) | A | B |
| Counter clockwise (CCW) | B | A |



The spring return feature in the control unit is not a safety device.

Dimensions

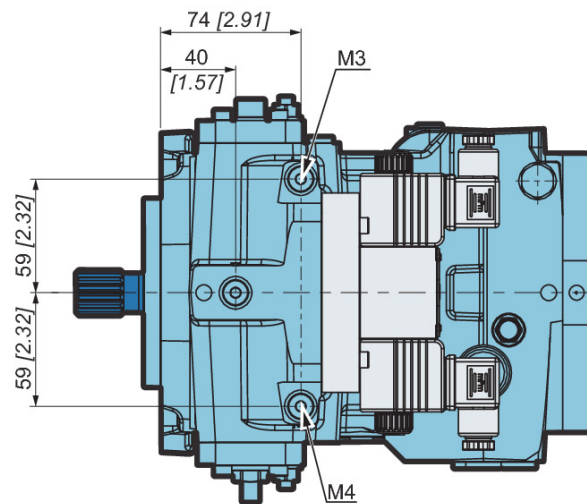
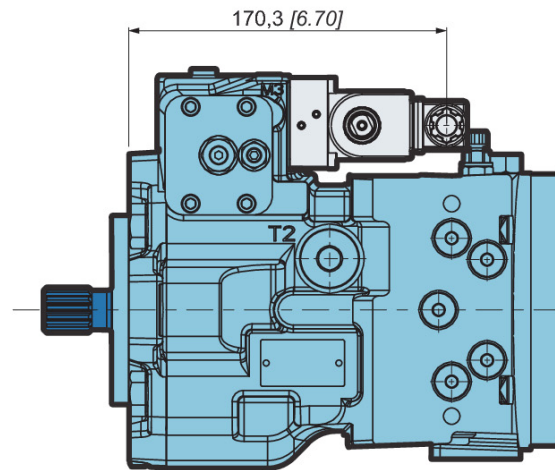
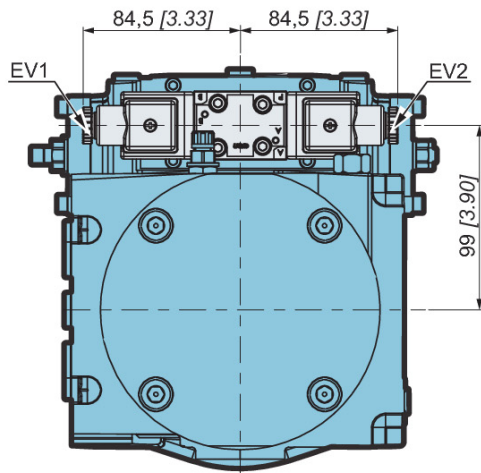

Solenoids specification

| | | |
|----------------------------|-----------------------|------------------------|
| Operating voltage | 12 VDC \pm 10% | 24 VDC \pm 10% |
| Current | 1500 mA | 750 mA |
| Resistance at 20°C [68 °F] | 5,3 Ω \pm 7% | 21,3 Ω \pm 7% |
| Connector type | DIN 43650 | |
| Power | 27 W | |
| Protection | IP65 | |
| Mass | 0,215 kg [0.47 lb] | |

See page 7 for other dimensions and page 6 for port characteristics.

Electro-proportional servo control



By means of a potentiometer and a control card, a current signal is applied to the proportional electrovalve coils which adjust the pressure of the servo control connected to the pump swashplate.

At every position of the potentiometer lever, there is a corresponding swashplate position.

The flow rate direction depends on which coil is excited.

The reaction time can be controlled by ramps installed on the card and by restrictors (Rs) positioned between the electrovalve and the servo control.

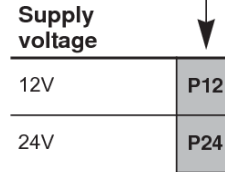

Flow rate determination

| Rotation | EV1 | EV2 |
|-------------------------|-----|-----|
| Clockwise (CW) | A | B |
| Counter clockwise (CCW) | B | A |

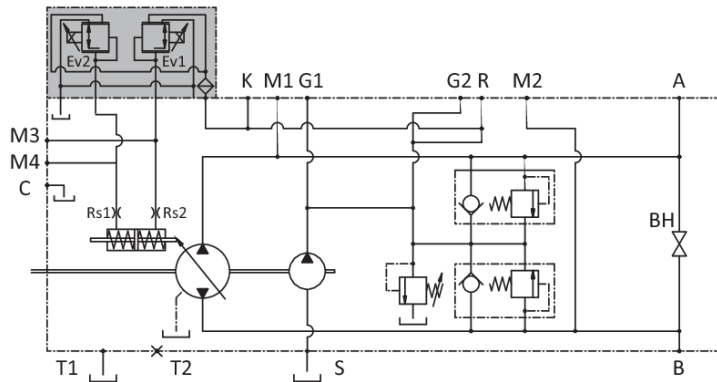

Electrovalve current vs Displacement

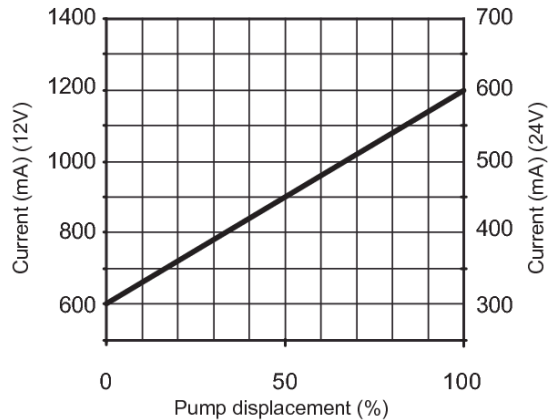

The current must not exceed 1500 mA under 12V and 800 mA under 24V.



The spring return feature in the control unit is not a safety device.

Dimensions

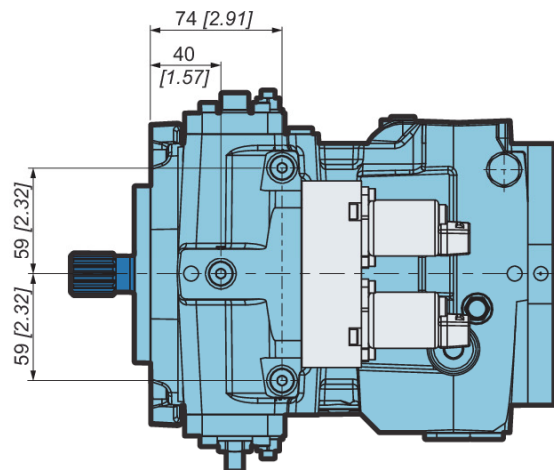
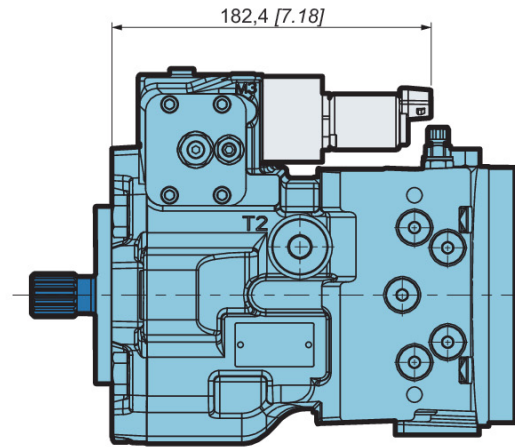
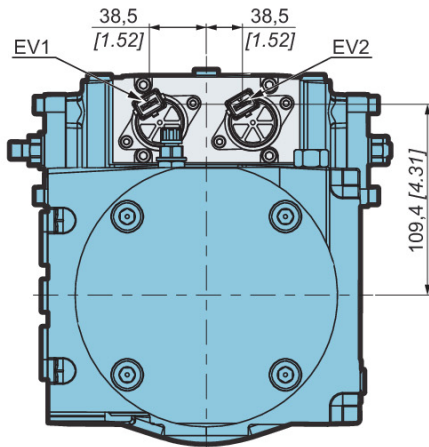

Solenoids specification

| | | |
|----------------------------|--|-------------|
| Operating voltage | 12 VDC | 24 VDC |
| Current | 1500 mA | 750 mA |
| Resistance at 20°C [68 °F] | 5,3 Ω ± 5% | 21,2 Ω ± 5% |
| Connector type | AMP Junior Timer (standard) Deutsch DT04-2P | |
| Protection | IP6K6 / IPX9K | |

See page 7 for other dimensions and page 6 for port characteristics.

OPTIONS

Roller bearing

| | | | | | | | | | | | |
|----------------|--------------------------|--------------------------|--------------------------|--------------------------|--------------------------|--------------------------|--------------------------|--------------------------|--------------------------|--------------------------|-----------|
| | 1 | 2 | 3 | 4 | 5 | 6 | 7 | 8 | 9 | 10 | 11 |
| P M 5 0 | <input type="checkbox"/> | <input type="checkbox"/> | <input type="checkbox"/> | <input type="checkbox"/> | <input type="checkbox"/> | <input type="checkbox"/> | <input type="checkbox"/> | <input type="checkbox"/> | <input type="checkbox"/> | <input type="checkbox"/> | CR |

It is an optional high capacity bearing.

Depending on the characteristics of shaft load, the duty cycle of the application and the expected life time of your application, Roller bearing might be needed.

Consult your Poclain Hydraulics Application Engineer.

Customized identification plate

| | | | | | | | | | | | |
|----------------|--------------------------|--------------------------|--------------------------|--------------------------|--------------------------|--------------------------|--------------------------|--------------------------|--------------------------|--------------------------|-----------|
| | 1 | 2 | 3 | 4 | 5 | 6 | 7 | 8 | 9 | 10 | 11 |
| P M 5 0 | <input type="checkbox"/> | <input type="checkbox"/> | <input type="checkbox"/> | <input type="checkbox"/> | <input type="checkbox"/> | <input type="checkbox"/> | <input type="checkbox"/> | <input type="checkbox"/> | <input type="checkbox"/> | <input type="checkbox"/> | DP |

It is possible to provide our products with dedicated plate (your part number engraved on the plate) when requested.



This option is available only for minimum volume of 50 pieces.



Consult your Poclain Hydraulics application engineer for other possibilities.

External inching

| | | | | | | | | | | | |
|----------------|--------------------------|--------------------------|--------------------------|--------------------------|--------------------------|--------------------------|--------------------------|--------------------------|--------------------------|--------------------------|-----------|
| | 1 | 2 | 3 | 4 | 5 | 6 | 7 | 8 | 9 | 10 | 11 |
| P M 5 0 | <input type="checkbox"/> | <input type="checkbox"/> | <input type="checkbox"/> | <input type="checkbox"/> | <input type="checkbox"/> | <input type="checkbox"/> | <input type="checkbox"/> | <input type="checkbox"/> | <input type="checkbox"/> | <input type="checkbox"/> | HI |

External pressure reducer (a joystic, an electronic device, etc.) can be fed with charge pressure from "G2" port. Modulated pressure come back to "K" port and it is used as pilot pressure for the control.

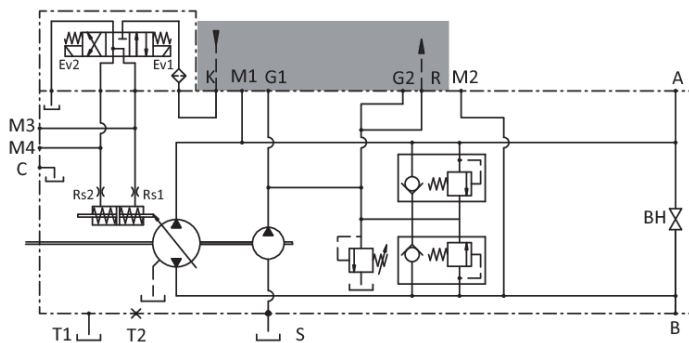

Filter on pressure line

The PM50 pumps can have a pressure filter without clogging indicator (F0) or with clogging indicator (F2). The flow thru the filter is only the flow that entry in the close loop. The filter fitness is of 10 micron.

Maximum pressure difference between filter cartridge input and output is 2 bar [29 PSI]. When reaching 2 bar [29 PSI], the cartridge has to be changed.

The max. working pressure is 30 bar [435 PSI].

Tightening torque: 35 Nm [309 in.lbf].

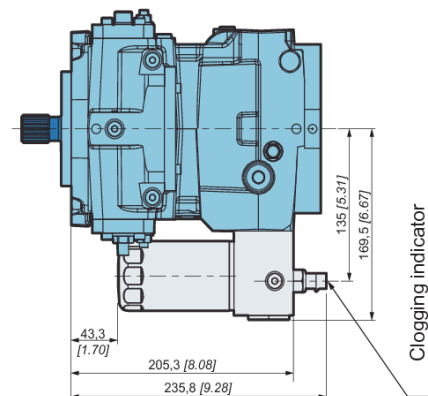
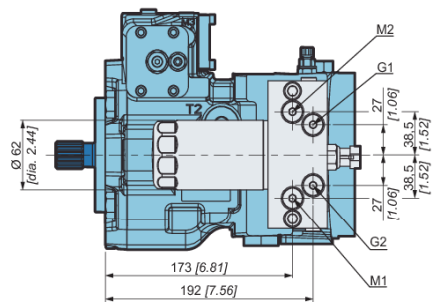
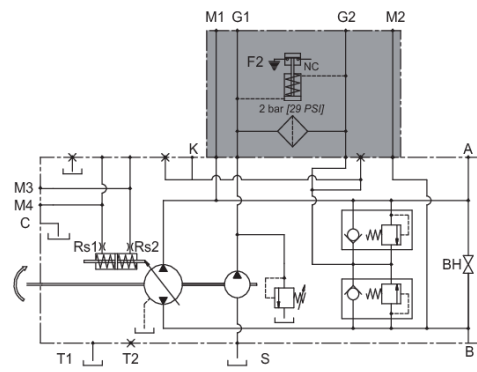
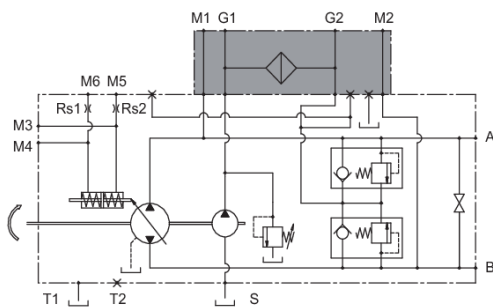
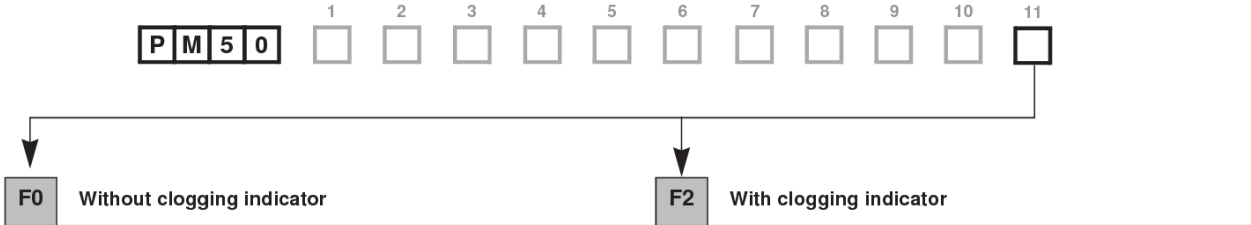

| Clogging indicator specification | |
|----------------------------------|----------------------------------|
| Differential working adjustment | 3 ± 0,2 bar [44 ± 3 PSI] |
| Working temperature | -30°C ~ 110 °C [-22 °F ~ 230 °F] |
| Max. vibration level | 50 g |
| Connector type | AMP super seal, 2 way |

External connections for filter

1 2 3 4 5 6 7 8 9 10 11

P M 5 0 F3

G1 = to filter on line
G2 = Return from filter on line

SAE flange ports

1 2 3 4 5 6 7 8 9 10 11

P M 5 0 FS

| Port | Function | SAE flange |
|-------|---------------------------|------------------------|
| A-B | Services | SAE PSI 6 000 4xM10 |
| C | Case pressure | 1/4" GAS |
| G1/G2 | Auxiliary/Charge pressure | 1/4" GAS |
| M1/M2 | A/B pressure | 1/4" GAS |
| M3/M4 | Servo control | 1/4" GAS |
| K | External servo pilot | 1/8" GAS |
| R | Servo pilot pressure | 1/4" GAS |
| S | Suction | 1" GAS |
| T1/T2 | Drain | 3/4" GAS |

UNF threads ports

1 2 3 4 5 6 7 8 9 10 11

P M 5 0 FU

| Port | Function | UNF ISO 11926-1 |
|-------|---------------------------|--------------------|
| A/B | Services | 1"5/16-12 UNF |
| C | Case pressure | 7/16-20 UNF |
| G1/G2 | Auxiliary/Charge pressure | 1/2-20 UNF |
| M1/M2 | A/B pressure | 1/2-20 UNF |
| M3/M4 | Servo control | 7/16-20 UNF |
| K | External servo pilot | 7/16-20 UNF |
| R | Servo pilot pressure | 1/2-20 UNF |
| S | Suction | 1"5/16-12 UNF |
| T1/T2 | Drain | 1"1/16-12 UNF |

Finishing coat



The pumps can be delivered with finishing coat when requested. Standard paint is RAL 9005 (black color).



Consult your Poclain Hydraulics application engineer for other colors of topcoat.

Flushing valve



On the pump cover, a flushing valve can be fitted with discharge inside the pump casing through a relief valve of the flushing valve. The exchange valve is useful in case the temperature of the oil in the closed circuit is too high.

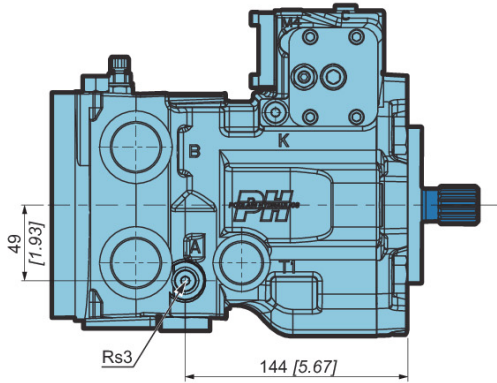
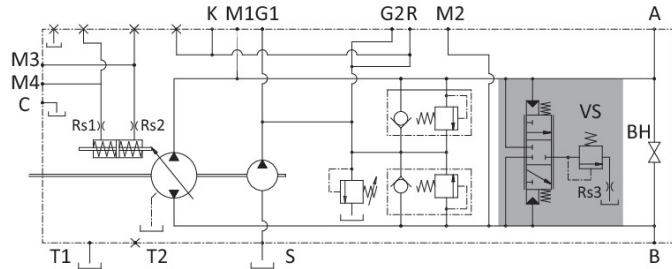
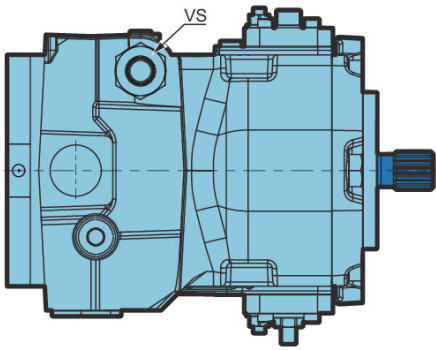

Flushing flow L/min [gal/min]

| | | Orifice diameter Rs3 mm [inch] | | |
|---------------------------------|----------|--------------------------------|-------------|-------------|
| | | 1,4 [0.055] | 1,8 [0.071] | 2,2 [0.087] |
| Delta pressure bar [PSI] | 20 [290] | 2,8 [0.75] | 4,5 [1.19] | 5,5 [1.46] |
| | 25 [363] | 3,6 [0.96] | 5,9 [1.55] | 7,2 [1.90] |
| | 30 [435] | 4,3 [1.13] | 7,0 [1.85] | 8,5 [2.26] |