



PM PUMPS



PM25. VARIABLE DISPLACEMENT PUMPS

OVERVIEW

PM25 is a variable displacement, axial piston pump, with swashplate system, for closed loop hydrostatic transmissions.

It provides a continuously variable flow rate between zero and maximum in forward and reverse direction. Flow rate is proportional to rotation speed and swashplate angle.

It can feature a charge pump to keep the circuit pressurised. This avoids risk of cavitations and ensures a good performance of the transmission.

It offers several types of control: servo hydraulic, hydraulic automotive, direct or servo mechanical, electrical and electro-proportional.

It is equipped with high pressure relief valves and can be delivered with auxiliary gear pumps.

It is available in single or tandem versions.

As options, PM25 can be featured with flushing valve, filter on charge pressure line and safety devices to ensure safe operation of the machine.

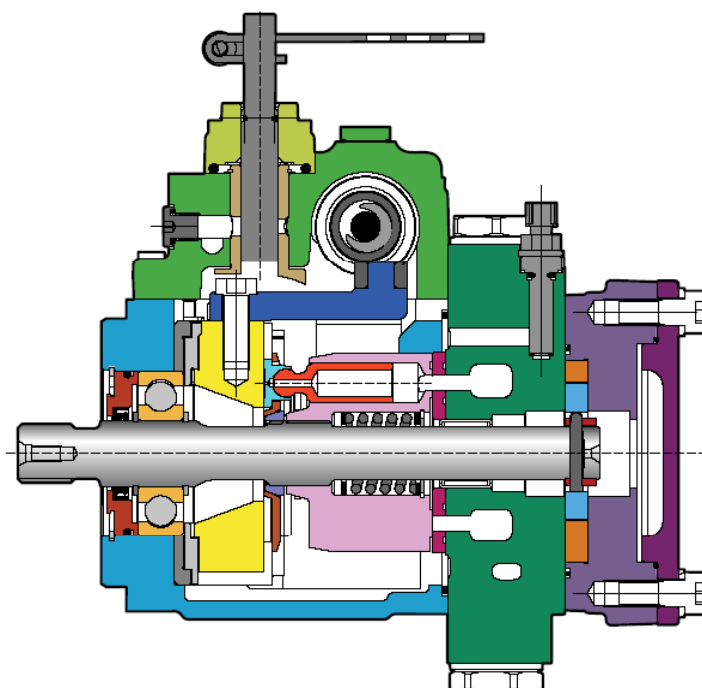

		PM25-20	PM25-25	PM25-28
Displacement	cm ³ /rev [in ³ /rev.]	20,5 [1.25]	25,7 [1.57]	28 [1.71]
Theoretical Flow at rated speed	L/min [GPM]	73,8 [19.50]	92,5 [24.44]	100,8 [26.63]
Rated speed	rpm	3 600		
Rated pressure	bar [PSI]	250 [3 625]		
Max. Pressure	bar [PSI]	350 [5 076]		
Mounting flange		SAE B		
Controls		Hydraulic, hydraulic automotive, direct or servo mechanical, electrical, electro-proportional		
Mass	kg [lb]	from 13 [28.7] to 18 [39.7]		
Rotation		Clockwise or Counterclockwise		

CONTENT

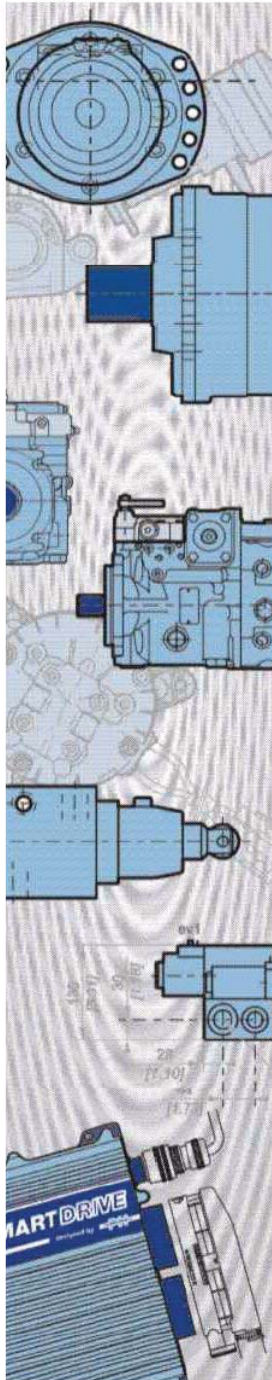

MODEL CODE	4	→	Model Code
TECHNICAL SPECIFICATIONS	6	→	Technical specifications
Features	6		
Performances	6		
Main dimensions	7		
Port characteristics	7		
OPERATING PARAMETERS	9	→	Operating Parameters
Operating parameters	9		
Charge pressure	9		
Case pressure	9		
Pressure ratings	9		
Speed ratings	9		
Inlet pressure	10		
Theoretical output	10		
Poclair Hydraulics recommendations for fluid	10		
Fluid and filtration	11		
Viscosity range	11		
SYSTEM DESIGN PARAMETERS	12	→	System design Parameters
Sizing equations	12		
Redundant braking system requirement	12		
Loop flushing	12		
Reservoir	13		
Case drain usage for tandem pump	13		
Differential pressure	13		
Bearing life and external shaft loading	14		
Hydraulic unit life	15		
Mounting flange loads	15		
FEATURES	16	→	Features
High pressure relief valve	16		
Charge relief valve	17		
Charge pump	18		
Displacement limiters	19		
By-pass	19		
Mounting flange and shafts	20		
Auxiliary mounting pad	22		
Tandem pumps	24		
Gear pumps	25		
CONTROLS	26	→	Controls
Direct mechanical control	26		
Mechanical servo control with feed back	28		
Hydraulic servo control	30		
Electrical on-off servo control	32		
Electro-proportional servo control	34		
Hydraulic automotive control	36		
OPTIONS	39	→	Options
Roller bearing	39		
Fluorinated elastomer seals	39		
UNF threads ports	39		
Filter on pressure line	40		
Pressure cut-off valve	41		
Mechanical inching	41		
Neutral position switch	42		
Flushing valve	43		

MODEL

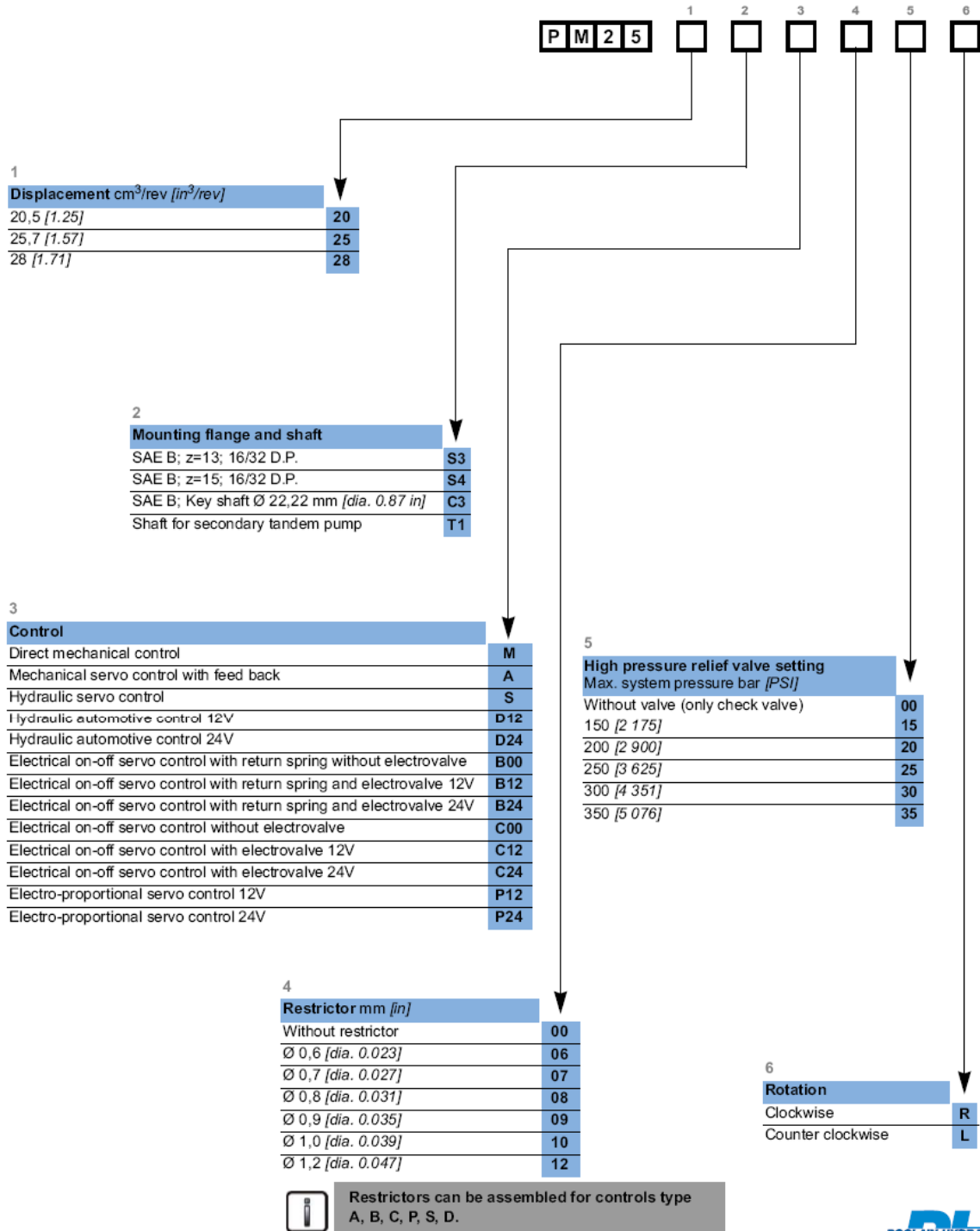

CODE

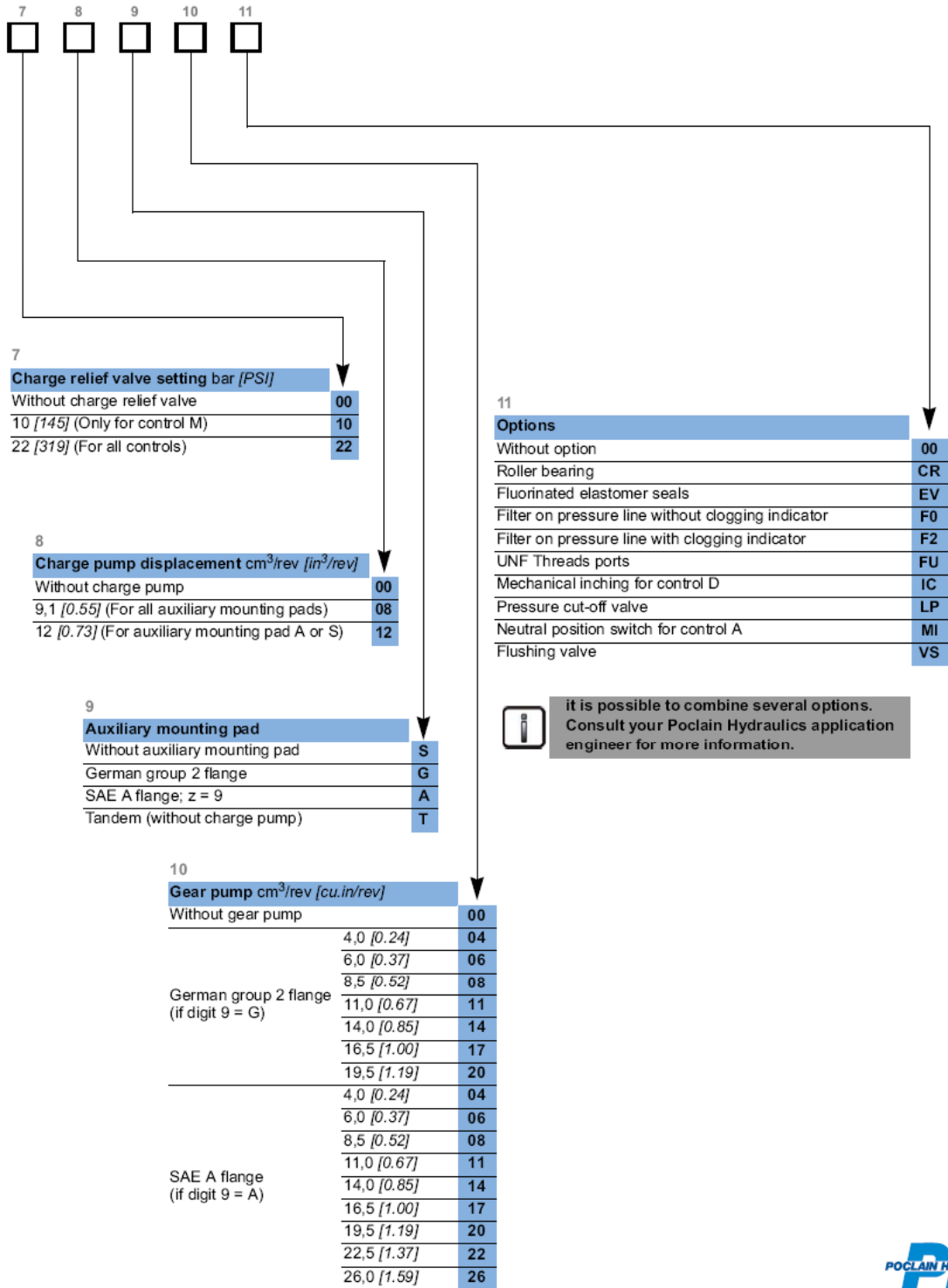

TECHNICAL SPECIFICATIONS

Features

		PM25-20	PM25-25	PM25-28
Displacement	cm ³ /rev [in ³ /rev.]	20,5 [1.25]	25,7 [1.57]	28 [1.71]
Theoretical flow at rated speed (3600 rpm)	L/min [GPM]	73,8 [19.50]	92,5 [24.44]	100,8 [26.63]
Max. Theoretical absorbed power at 320 bar [4 641 PSI]	KW	39,4	49,3	53,8
Theoretical absorbed torque at 100 bar [1 450 PSI]	N.m [in.lbf]	32,6 [288]	40,9 [362]	44,6 [395]
Moment of inertia	kg.m ² [slug.ft ²]		0.0014 [0.0010]	
Internal charge pump	cm ³ /rev [in ³ /rev.]		9,1 [0.55] or 12 [0.73]	
Charge relief valve setting	bar [PSI]		From 10 [145] to 30 [435]	
High pressure relief setting	bar [PSI]		Max. 350 [5 076]	
Mounting flange			SAE B	
Mass	kg [lb]		18 [39.7] with control M 22,2 [48.9] with controls A, B, C, P, S 24,7 [54.4] with control D	

Performances

Efficiency at the max. pump displacement

Oil ISO VG46, temperature = 50°C [122°F].

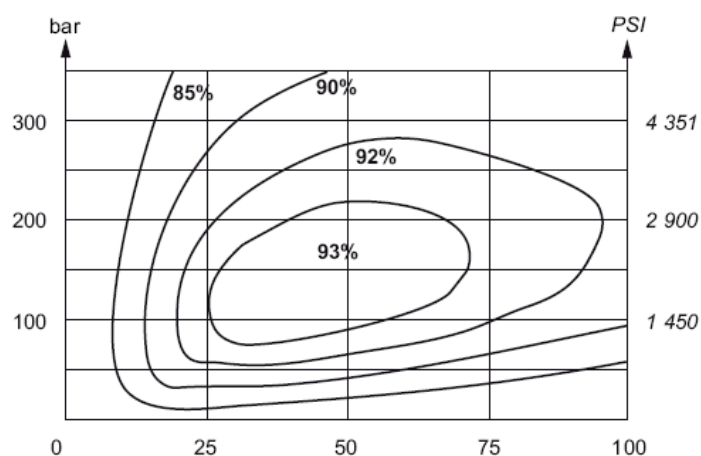

TECHNICAL SPECIFICATIONS

Main dimensions

PM 25 - SAE B - splined shaft with servo hydraulic control and without auxiliary mounting pad

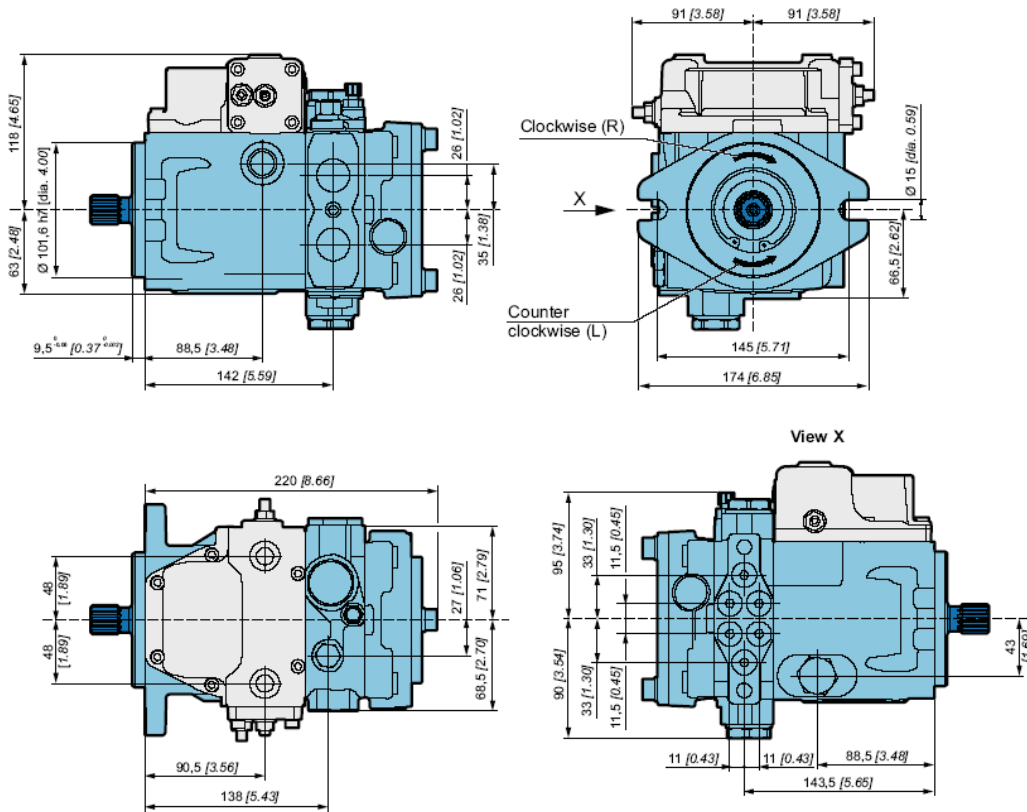

Port characteristics

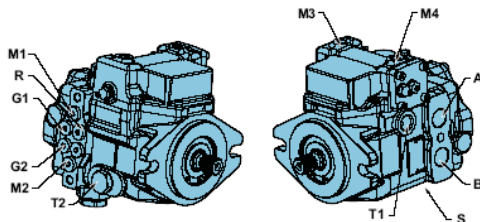

Port	Function	ISO 1179-1 (standard)	ISO 11926-1 (option FU)
A-B	Services	3/4" GAS	1 1/6-12-UNF
G1/G2	Auxiliary	1/4" GAS	9/16-18-UNF
M1/M2	A-B pressure	1/4" GAS	9/16-18-UNF
M3/M4	Servo control pilot	1/4" GAS	9/16-18-UNF
R	Servo pilot pressure	1/4" GAS	-
S	Suction	3/4" GAS	1 1/6-12-UNF
T1/T2	Drain	1/2" GAS	3/4-16-UNF



OPERATING PARAMETERS

Operating parameters			PM25-20	PM25-25	PM25-28
Speed ratings	Minimum			700	
	Max. without load	min ⁻¹ (rpm)		3 900	
	Max. with load			3 600	
System pressure	Rated			250 [3 625]	
	Maximum	bar [PSI]		370 [5 366]	
	Minimum low loop			10 [145]	
Inlet pressure	Mini continuous	bar (abs.) [in. Hg vac.]		0,8 [11.6]	
	Mini (cold start)			0,5 [7.2]	
Case pressure	Continuous	bar [PSI]		1,5 [21.7]	
	Maximum (cold start)			2,5 [36.2]	
Charge pressure	Standard version	bar [PSI]	10 [145] for control M; 22 [319] for other controls		
	Max. charge pressure			30 [435]	

Charge pressure

A charge flow is required to maintain a positive pressure in the low pressure loop of a closed loop hydrostatic transmission. Charge pressure ensures proper lubrication and rotating group operation. It is recommended to maintain the charge pressure at a minimum of 10 bar [145 PSI] above case pressure. For more details, refer to charge pump paragraph, page 18.

Case pressure

Case pressure must be maintained within the limits shown in the table "Operating parameters". Ensure housing is always filled with hydraulic fluid and especially during start-up of the machine.

Pressure ratings

Maximum peak pressure

It is the maximum allowable pressure. It is equivalent to the maximum setting of the maximum high pressure relief valve. A self-propelled machine can reach the maximum peak pressure value no more than 1-2% of that work cycle.

Work cycle

A fundamental factor for ensuring correct hydrostatic transmission sizing is the machine work cycle (pressure-time ratio, seasonality, pressure vs. percentage of time at max. displacement, machine type). Part service life depends on the correct choice in relation to the work cycle.

Overloads

It is mandatory to protect parts against any possible overloads.

Speed ratings

The table "Operating parameters" gives minimum and maximum rated speeds. Note that all displacements might operate under different speed limits. Definitions of these speed limits appear below.

Maximum speed is the highest operating speed allowed. Over speeding reduces pump life time, can lead to loss of hydrostatic power and braking capacity. Never exceed the maximum speed limit under any operating conditions.

Nominal speed is the speed offering the maximal efficiency.

Inlet pressure

Charge pump inlet pressure is key for acceptable pump life and performances. A continuous inlet pressure of not less than 0,8 bar abs. [11.6 PSI abs.] is recommended. A continuous inlet pressure less than 0.5 bar abs. [7.2 PSI abs.] indicates inadequate inlet design or a restricted filter. Pressures less than 0.5 bar abs. [7.2 PSI abs.] can happen at cold start, but should increase with oil temperature.

Theoretical output

Theoretical output flow is a function of pump displacement and speed. It is relevant to size the rest of the circuit. Theoretical flow does not take into account losses due to leakage or variations in displacement. Refer to performances, page 6, for volumetric and overall efficiencies at various operating speeds and pressures.

Poclairn Hydraulics recommendations for fluid



Poclairn hydraulics recommends the use of hydraulic fluids defined by the ISO 12380 and ISO 6743-4 standards. For temperate climates, the following types are recommended.

- HM 46 or HM 68 for fixed installations.
- HV 46 or HV 68 for mobile installations.
- HEES 46 for mobile installations.

These specifications correspond to category 91H of the CETOP standard, parts 1, 2 and 3 of the DIN 51524 standard, and grades VG32, VG 46 and VG68 of the ISO 6743-4 standards.



It is also possible to use ATF, HD, HFB, HFC or HFD type hydraulic fluid upon Poclairn Hydraulics specific approval of the components' operating conditions.

Standardized designations for the fluids

- **HM** : Mineral fluids having specific antioxidant, anticorrosion and antiwear properties (HLP equivalent to DIN 51524 parts 1 and 2).
- **HV** : HM mineral fluids providing improved temperature and viscosity properties (DIN 51524 part 3).
- **HEES** : Biodegradable fluids based on organic esters.



It is also possible to use a fluid that meets the biodegradability criteria and is compatible in the event of accidental food contact. The BIOHYDRAN FG 46 fluid designed by the company Total has undergone testing of its properties and performance on our test benches. Since this type of fluid has not yet been categorized, it is the responsibility of machine manufacturers to validate its compatibility with all of the components used in order to guarantee that the intended functions will be fulfilled and this for the desired life time of all equipment items.



For biodegradable fluids, consult your Poclairn Hydraulics' application engineer



During operation, the temperature of the oil must be between 0°C [32°F] and 80°C [176°F]; the minimum and maximum temperatures may be exceeded momentarily by ± 20°C [± 68°F] for a duration of less than 30 minutes. For all applications outside these limits, please consult with your Poclairn Hydraulics' application engineer.

Fluid and filtration

The contaminating particles suspended in the hydraulic fluid cause the hydraulic mechanisms moving part wear. On hydraulic pumps, these parts operate with very small dimensional tolerances. In order to reach the part life, it is recommended to use a filter that maintains the hydraulic fluid contamination class at a max. of:

9 according to NAS 1638
20/18/15 according to ISO 4406:1999

According to the type of application decided for the pump, it is necessary to use filtration elements with a filtration ratio of:

$\beta_{20 \text{ to } 30} \geq 100$

Making sure that this ratio does not worsen together with the increasing of the filter cartridge differential pressure.

If these values cannot be observed, the component life will consequently be reduced and it is recommended to contact the Poclain Hydraulics Customer Service.

Filters on charge circuit

Filters on the charge circuit (F0-F2) are designed without by-pass. The max. pressure drop on the filtration part must not exceed 2 bar [29 PSI] (3 bar [43.5 PSI] in case of cold starting) at pump full rating. To monitor the pressure drop, it is recommended to use the clogging indicator on the filtration element (F2 option). Contact your Poclain Hydraulics Application engineer, each time the pump is not charged by its internal charge pump.

Filters on charge circuit are mounted on the pump special support.

Filters assembling

The suction filter is mounted on the suction line. Check that the pressure before the charge pump is 0.8 bar abs. [11.6 PSI abs.], measured on the pump suction port (0.5 bar [7.2 PSI] for cold starting).

Viscosity range

For both max. efficiency and life of the unit, the operative viscosity should be chosen within the optimum range of:

ν_{opt} = optimum operating viscosity from 16 to 36 mm^2/s [from 74.1 to 166.8 SUS] referred to the closed loop temperature.

Working conditions: the following limits of viscosity apply

ν_{min} = 5 mm^2/s [23 SUS] short-duration at a max. permissible leakage oil temperature of 90° C [194°F]

ν_{max} = 1000 mm^2/s [4 634 SUS] short-duration, on cold start.

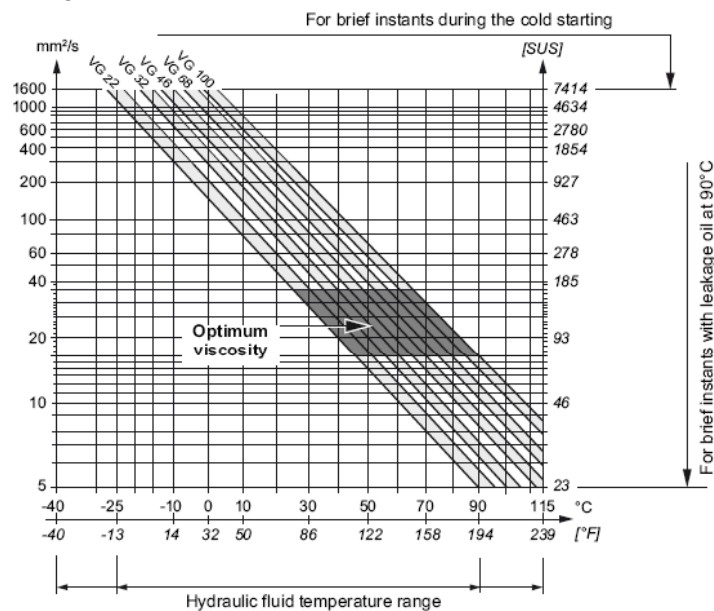

Ensure fluid temperature and viscosity limits are concurrently satisfied.



SYSTEM DESIGN PARAMETERS



Consult your Poclain Hydraulics application engineer to validate your design parameters before using the pump in your application.

Sizing equations

The following equations are helpful when sizing hydraulic pumps. Generally, the sizing process is initiated by an evaluation of the machine system to determine the required motor speed and torque to perform the necessary work function. First, the motor is sized to transmit the maximum required torque. The pump is then selected as a flow source to achieve the maximum motor speed.

	Output flow Q	=	$\frac{V_g \cdot n \cdot \eta_v}{1000}$	(l/min)	
SI units	Input torque M	=	$\frac{V_g \cdot \Delta p}{20 \cdot \pi \cdot \eta_m}$	(N.m)	
	Input power P	=	$\frac{M \cdot n \cdot \pi}{30\,000} = \frac{Q \cdot \Delta p}{600 \cdot \eta_t}$	(kW)	
	Output flow Q	=	$\frac{V_g \cdot n \cdot \eta_v}{231}$	(GPM)	
US units	Input torque M	=	$\frac{V_g \cdot \Delta p}{2 \cdot \pi \cdot \eta_m}$	(lbf.in)	
	Input power P	=	$\frac{M \cdot n \cdot \pi}{198\,000} = \frac{Q \cdot \Delta p}{1714 \cdot \eta_t}$	(hp)	

V_g = Displacement per revolution cm^3/tr [in^3/rev]
 Δp = $p_o - p_i$ (system pressure) bar [PSI]
 n = Speed min^{-1} [rpm]
 η_v = Volumetric efficiency
 η_m = Mechanical efficiency
 η_t = Overall efficiency ($\eta_v \cdot \eta_m$)

Redundant braking system requirement



Unintended vehicle or machine movement hazard.

The loss of hydrostatic drive line power, in any mode of operation (forward, neutral, or reverse) may cause the system to lose hydrostatic braking capacity. You must provide a braking system, redundant to the hydrostatic transmission, sufficient to stop and hold the vehicle or machine in the event of hydrostatic drive power loss.

Loop flushing

Closed circuit may require a flushing valve to meet temperature and cleanliness requirements. A flushing valve takes a part of hot fluid flow from the low pressure loop of the system loop for cooling and filtering. Make sure that the charge pump provides adequate flow for the flushing valve and the flushing valve does not cause charge pressure to drop below recommended limits.

See option VS page 43 for more information

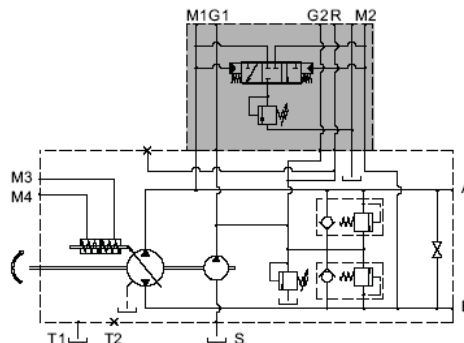

Reservoir

The reservoir provides clean fluid, dissipates heat, and removes entrained air from the hydraulic fluid. It allows for fluid volume changes associated with fluid expansion and cylinder differential volumes. Minimum reservoir capacity depends on the volume needed to perform these functions. Typically, a capacity of one half the charge pump flow (per minute) is satisfactory for a closed reservoir. Open circuit systems sharing a common reservoir require greater fluid capacity.

Locate the reservoir outlet (suction line) near the bottom, allowing clearance for settling foreign particles. Use a 100 - 125 μm screen covering the outlet port.

Place the reservoir inlet (return lines) below the lowest expected fluid level, as far away from the outlet as possible.

Use a baffle (or baffles) between the reservoir inlet and outlet ports to promote de-aeration and reduce fluid surging.

Case drain usage for tandem pump

On tandem pumps, and to ensure lubrication of both pumps, excess flow from the second pump charge relief valve must be routed into the housing of the first pump.

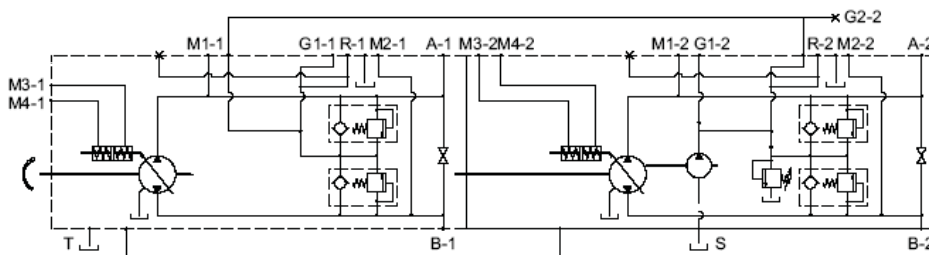

Differential pressure

The differential pressure is the High pressure relief valve setting minus Charge relief valve setting.

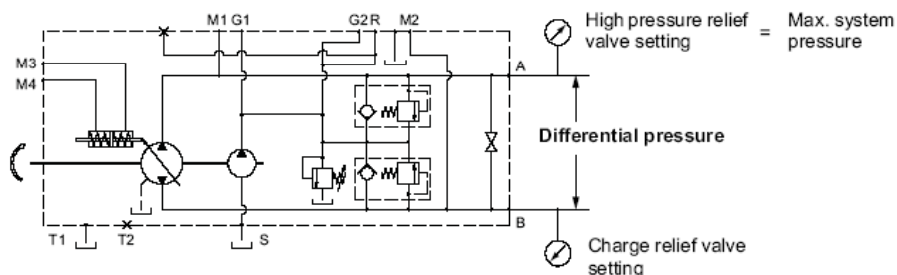

Bearing life and external shaft loading

Bearing life:

Bearing life is a function of speed, pressure, swashplate angle and external loads. Oil type and viscosity impact bearing life.

Bearing life (B_{10} hours)	
PM25-28	12 900

Normal bearing life in B_{10} hours is shown in the above table. Figures have been calculated under the following operating conditions: a continuous differential pressure of 130 bar [1 885 PSI], 1 800 rpm shaft speed, maximum displacement, without any external shaft side load. The data is based on a 50% forward, 50% reverse duty cycle, standard charge pump size, and standard charge pressure.

Shaft Loads:

PM25 pumps are designed with bearings that can accept external radial and thrust loads. The external radial shaft load limits depend on the load position, orientation, and operating conditions of the unit.

The maximum permissible radial load (Re), is based on the maximum external moment (Me), and the distance (L) from the mounting flange to the load. It may be determined using the table and formula below. Thrust (axial) load limits are also shown.

$$Re = Me / L$$

All external shaft loads affect bearing life. In applications with external shaft loads, minimize the impact by positioning the load at 90° or 270° as shown in the figure.

Contact your Poclairn Hydraulics representative for an evaluation of unit bearing life if:

- Continuously applied external loads exceed 25 % of the maximum allowable radial load Re .
- The pump swashplate is positioned on one side of center all or most of the time.
- The unit bearing life (B_{10}) is critical.

PM25-28	External moment (Me)	Maximum shaft thrust in (T_{in})
	N.m [in.lbf]	N [lbf]
	44 [389]	1 000 [224.8]

at 120 bar [1 740 PSI] and 3 600 rpm

Radial and thrust load position

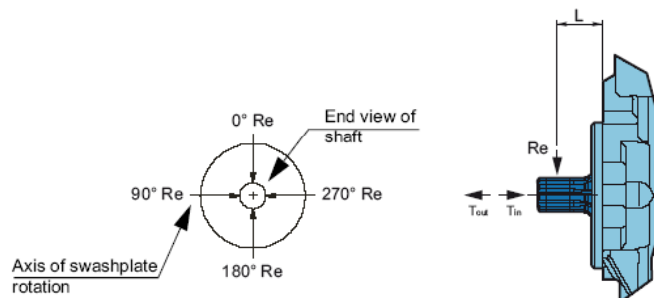

For an accurate calculation, consult your Poclairn Hydraulics application engineer.



Hydraulic unit life

Hydraulic unit life is the life expectancy of the hydraulic components. It depends on speed and system pressure even if, system pressure is the dominant operating variable. High pressure, generated by high load, reduces hydraulic unit life.

Design the hydraulic system according to the expected machine duty cycle. Take in consideration the expected percentages of time at various loads and speeds. Ask your Poclain Hydraulics representative to calculate an appropriate pressure based your hydraulic system design. If duty cycle data is not available, input power and pump displacement are used to calculate system pressure.

All pressure limits are differential pressures (referenced to charge pressure), taking a normal charge pressure in consideration.

PM25 pumps will meet satisfactory life expectancy if applied within the parameters specified in this technical documentation. For more detailed information on hydraulic unit life see Operating Parameters in page 9.

Mounting flange loads

Adding tandem mounted pumps, and/or tandem auxiliary pump(s), subjecting pumps to shock loads may generate excessive loads on the front mounting flange. The overhung load moment for multiple pump mounting can be estimated as shown in the figure below

Overhung load example

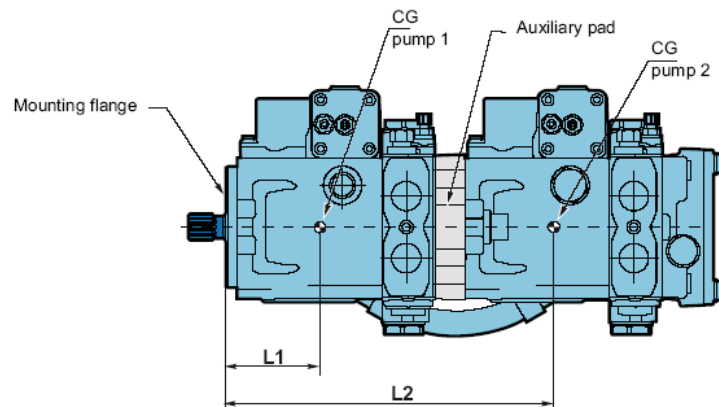

Estimating overhung load moments

W = Weight of pump (kg)
 L = Distance from mounting flange to pump center of gravity (CG)
 $M_R = G_R (W_1 L_1 + W_2 L_2 + \dots + W_n L_n)$
 $M_S = G_S (W_1 L_1 + W_2 L_2 + \dots + W_n L_n)$

Where:

M_R = Rated load moment (N.m)
 M_S = Shock load moment (N.m)
 G_R^* = Rated (vibratory) acceleration (G's) (m/sec²)
 G_S^* = Maximum shock acceleration (G's) (m/sec²)

*Calculations will be carried out by multiplying the gravity ($g = 9.81 \text{ m/sec}^2$) with a given factor. This factor depends on the application.

Allowable overhung load moment are shown in the above table. Exceeding these values requires additional pump support.

	Rated moment (MR)	Shock load moment (MS)
	N.m [in.lbf]	N.m [in.lbf]
PM25-20	370 [3 274]	600 [5 310]
PM25-25	370 [3 274]	600 [5 310]
PM25-28	370 [3 274]	600 [5 310]



For an accurate calculation, consult your Poclain Hydraulics application engineer.



FEATURES

High pressure relief valve

The high pressure relief valves maintain circuit pressure in the proper range. The check valves allow charge flow to replenish the low pressure loop of the circuit. The high pressure relief valves ensure a high pressure protection of the high pressure loop of the circuit.

High pressure relief valves are available in a range of settings.

When high pressure relief valves are not desired, pumps is equipped with charge circuit check valves only.



High pressure relief valves are intended for transient overpressure protection and are not intended for continuous pressure control. Flow over relief valves for extended periods of time may result in severe heat build up. High flows over relief valves may result in pressure levels exceeding the nominal valve setting and potential damage to system components.



High pressure relief valve	Available setting bar [PSI]	
Without	-	00
	150 [2 175]	15
	200 [2 900]	20
With	250 [3 625]	25
	300 [4 351]	30
	350 [5 076]	35

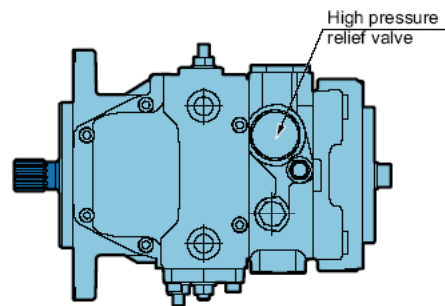
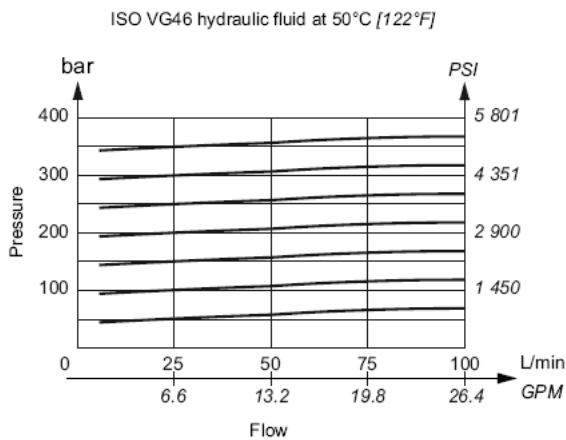
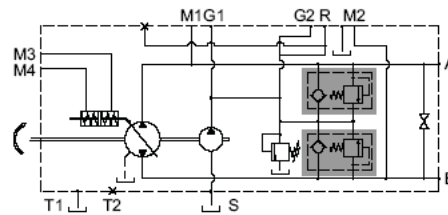

The high pressure relief valve setting is not the differential pressure between A and B ports (see page 13).



FEATURES

Charge relief valve

The charge pressure relief valve provides a relief outlet for charge circuit. This valve is used to set the charge pressure of the circuit. Flow through the valve is ported to case.

The nominal charge relief setting is referenced to case pressure.



Incorrect charge pressure settings may result in the inability to build required system pressure and/or inadequate loop flushing flows. Ensure correct charge pressure under all conditions of operation to maintain pump control performance.



Charge relief valve	Available setting bar [PSI]	
Without	-	00
With	Only for control M	10 [145]
	For all controls	22 [319]

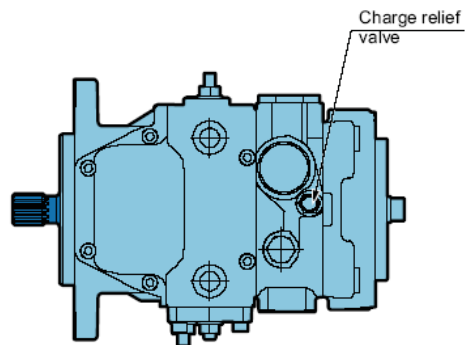
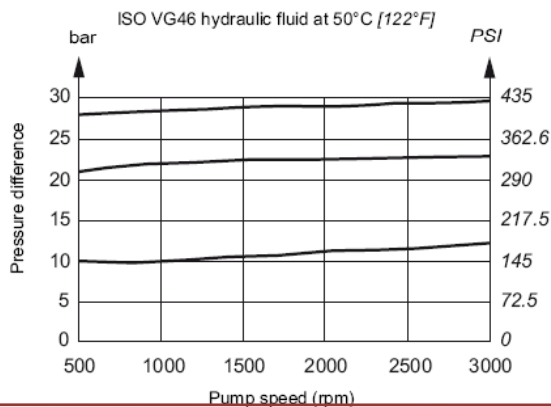
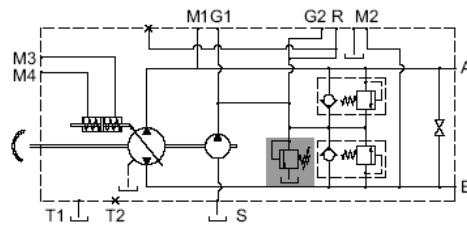

Charge pump

Charge flow is required on all PM25 pumps used in closed circuit installations. The charge pump provides flow to make up internal leakage, maintain a positive pressure in the main circuit, provide flow for cooling and filtration, replace any leakage losses from external valving or auxiliary systems, and to provide flow and pressure for the control system.

Many factors influence the charge flow requirements. These factors include system pressure, pump speed, pump swashplate angle, type of fluid, temperature, size of heat exchanger, length and size of hydraulic lines, control response characteristics, auxiliary flow requirements, hydrostatic motor type, etc.

Unusual application conditions may require a more detailed review of charge pump sizing. Charge pressure must be maintained at a specified level under all operating conditions to prevent damage to the transmission. Poclain Hydraulics recommends testing under actual operating conditions to verify this.

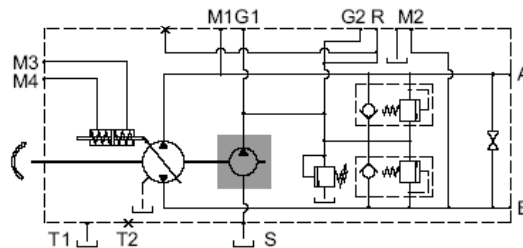

Charge pump sizing/selection

In most applications a general guideline is that the charge pump displacement should be at least 20% of the main pump displacement.

1
 2
 3
 4
 5
 6
 7
 8
 9
 10
 11

Charge pump		Displacement cm ³ /rev [in ³ /rev]	Rated speed rpm	
Without		-	-	00
With	For all auxiliary mounting pads	9,1 [0.55]	3900	08
	Only auxiliary mounting pad A	12 [0.73]	3900	12



Contact your Poclain Hydraulics application engineer for more information.



Displacement limiters

PM25 are designed with mechanical displacement (stroke) limiters. You can limit maximum displacement of the pump to a certain percent of its maximum displacement to near zero in both direction.

The displacement limiters are located on the both sides of the servo piston and are adjustable by screw.



Take care in adjusting displacement limiters to avoid an undesirable condition of output flow or speed. Retorque the sealing lock nut after every adjustment to prevent an unexpected change in output conditions and to prevent external leakage during pump operation.

PM25 with control M

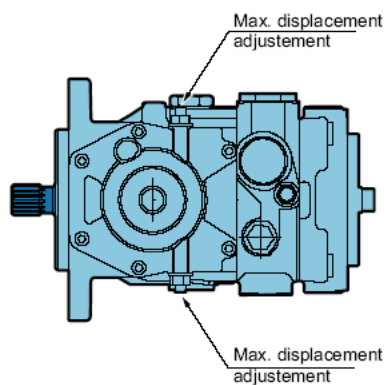

PM25 with other controls

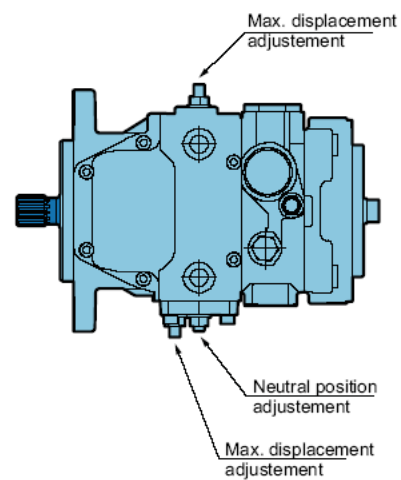

By-pass

PM25 features a by-pass function. By-passing Port A and Port B is achieved by unscrewing a screw located on the cover. The by-pass connect the ports A-B and must be use only in emergency case and only for short movement.

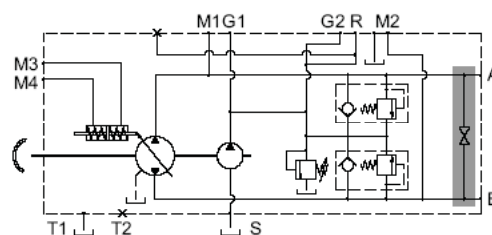

To avoid leakage, do NOT exceed two turns of the screw.



By-pass valve is intended for moving a machine for very short distances at very slow speeds. It is NOT intended as tow valve.

Mounting flange and shafts

SAE B - Splined shaft



S3 13 teeth

Max. torque: 220 Nm [1947 in.lbf]

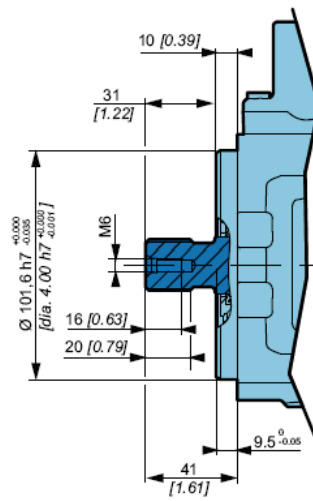

Splined ANSI B92.1a-1976
Pitch 16/32" DP
Pressure angle 30°
Tolerance class: 5

S4 15 teeth

Max. torque: 360 Nm [3186 in.lbf]

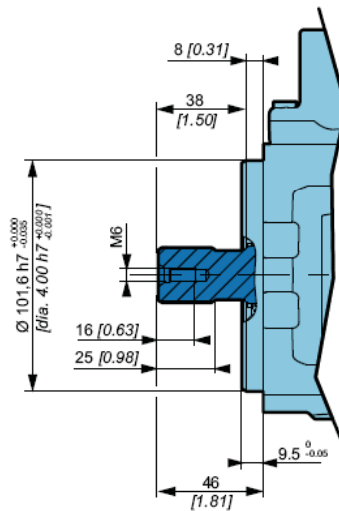

Splined ANSI B92.1a-1976
Pitch 16/32" DP
Pressure angle 30°
Tolerance class: 5



Auxiliary mounting pad

SAE A flange



00	Without charge pump
8	With charge pump: 9,1 cm ³ /rev [0.55 in ³ /rev]
12	With charge pump: 12,0 cm ³ /rev [0.73 in ³ /rev]

Max. Torque: 80 N.m [708 in.lbf]

Splined ANSI B92.1a-1976
 Pitch 16/32" DP
 Pressure angle 30°
 9 teeth
 Tolerance class: 5

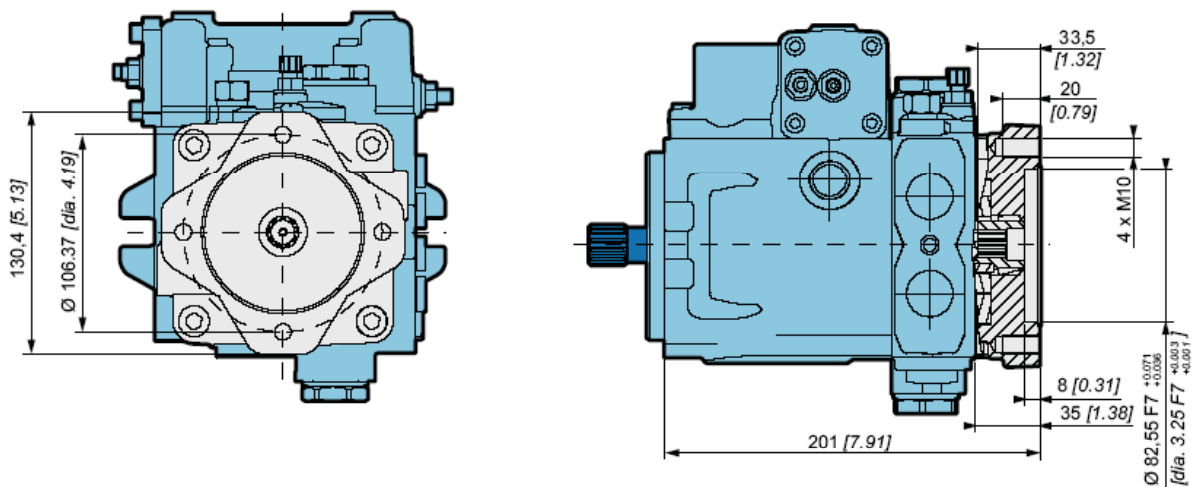

Do not rotate the auxiliary mounting pad cover.

German group 2 flange



- 00** Without charge pump
- 08** With charge pump: 9,1cm³/rev [0.55 in³/rev]

Max. torque: 48 N.m [425 in.lbf]

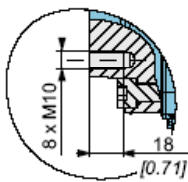
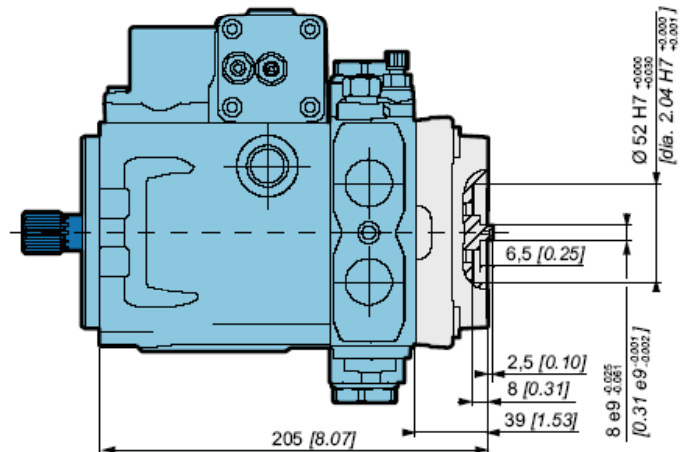
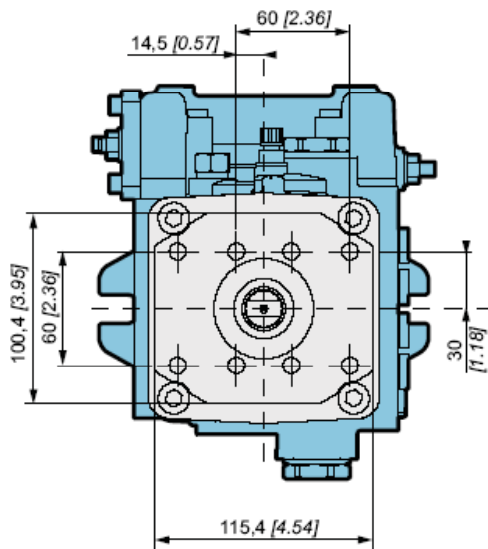

Do not rotate the auxiliary mounting pad cover.



Tandem pumps

Max. torque intermediate coupling
200 N.m [1 770 in.lbf]

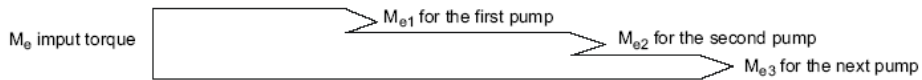
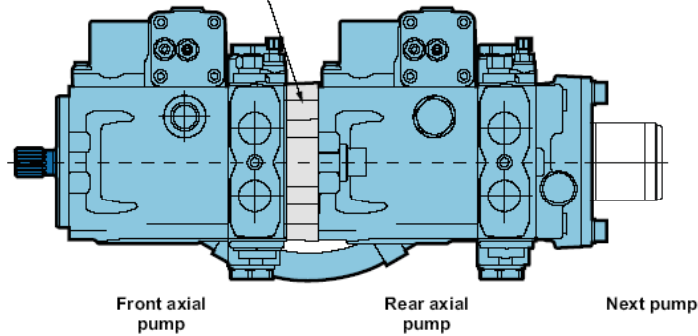

Torque required by auxiliary pumps is additive. Ensure requirements don't exceed shaft torque ratings.

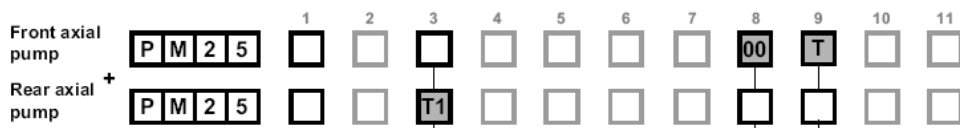

Number of charge pump in the tandem	Axial pump	Mounting flange and shaft		Charge pump	Auxiliary mounting flange		
		SAE B; 13 teeth	S3		SAE B; 15 teeth	S4	Tandem fitting
0 charge pump	Front	SAE B; 13 teeth	S3	Without	00	Tandem fitting	T
	Rear	SAE B; 15 teeth	S4	Without	00	SAE A flange	A
1 charge pump*	Front	SAE B; 13 teeth	S3	Without	00	Tandem fitting	T
	Rear	SAE B; 15 teeth	S4	With	08 or 12	SAE A flange	A
		Shaft for secondary tandem pump	T1			Without auxiliary mounting pad	S



* The charge pump can only be located on the rear axial pump.



Ports T and G of the first pump must be connected with ports T and G of the second pump.



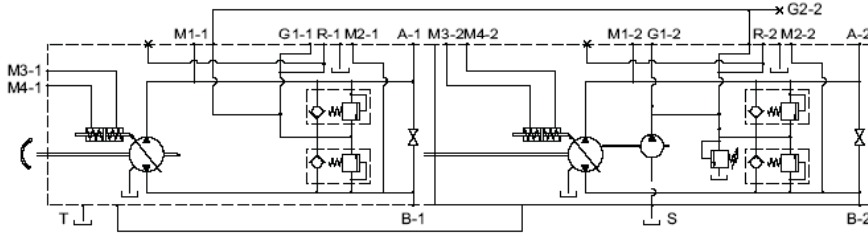

Gear pumps



Auxiliary mounting pad

Gear pump

	Displacement	Pressure			Dimension			Mass	Efficiency	
		Continuous max. pressure	Max. intermittent pressure	Max. peak pressure	A	B	C			
	cm ³ /rev [cu.in/rev]	bar [PSI]	bar [PSI]	bar [PSI]	mm [in]	mm [in]	mm [in]	Kg [lb]	%	
German group 2 	04	4 [0.24]	250 [3 625]	270 [3 915]	290 [4 205]	90,3 [3.55]		2,30 [5.07]	95*	
	06	6,0 [0.37]	250 [3 625]	270 [3 915]	290 [4 205]	93,6 [3.68]		2,45 [5.40]		
	08	8,5 [0.52]	250 [3 625]	270 [3 915]	290 [4 205]	97,8 [3.85]		2,60 [5.73]		
	11	11,0 [0.67]	250 [3 625]	270 [3 915]	290 [4 205]	101,9 [4.01]	88 [3.46]	100 [3.94]		2,70 [5.95]
	14	14 [0.85]	250 [3 625]	270 [3 915]	290 [4 205]	106,9 [4.21]		2,80 [6.17]		
	17	16,5 [1.01]	230 [3 335]	240 [3 480]	250 [3 625]	111,1 [4.37]		2,95 [6.51]		
	20	19,5 [1.19]	210 [3 045]	220 [3 190]	230 [3 335]	116,1 [4.57]		3,10 [6.84]		
SAE A flange 	04	4 [0.24]	250 [3 625]	270 [3 915]	290 [4 205]	93,0 [3.66]		2,30 [5.07]	95*	
	06	6,0 [0.37]	250 [3 625]	270 [3 915]	290 [4 205]	96,3 [3.68]		2,45 [5.40]		
	08	8,5 [0.52]	250 [3 625]	270 [3 915]	290 [4 205]	100,5 [3.96]		2,60 [5.73]		
	11	11,0 [0.67]	250 [3 625]	270 [3 915]	290 [4 205]	104,6 [4.12]		2,70 [5.95]		
	14	14 [0.85]	250 [3 625]	270 [3 915]	290 [4 205]	109,6 [4.21]	130,4 [5.13]	95 [3.74]		2,80 [6.17]
	17	16,5 [1.01]	230 [3 335]	240 [3 480]	250 [3 625]	113,8 [4.37]		2,95 [6.51]		
	20	19,5 [1.19]	210 [3 045]	220 [3 190]	230 [3 335]	118,8 [4.68]		3,10 [6.84]		
	22	22,5 [1.37]	190 [2 755]	200 [2 900]	210 [3 045]	123,8 [4.87]		3,25 [7.17]		
	26	26 [1.59]	170 [2 465]	180 [2 610]	190 [2 755]	129,6 [5.10]		3,40 [7.50]		

* Value collected during the testing at 1500 rpm



Gear pumps are always delivered flanged on the axial pump. They can not be sold alone.



CONTROLS

Direct mechanical control



The variation in pump displacement is obtained by rotating the lever shaft in a clockwise or counter-clockwise direction.

The lever shaft is directly linked to the pump swashplate.

The angle is at 15° for 20,5 cm³/rev [1.25 in³/rev] displacement and at 18° for 25,7 cm³/rev [1.57 in³/rev].

Flow rate determination

Rotation	Control	Output	Input
Clockwise (R)	X	A	B
	Y	B	A
Counter clockwise (L)	X	B	A
	Y	A	B

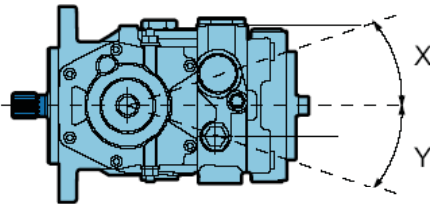
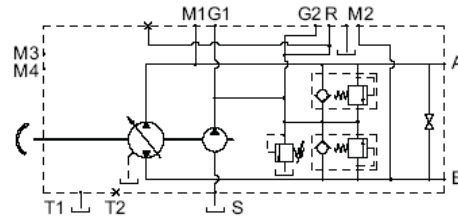

100% displacement cm ³ /rev [in ³ /rev]	X/Y angle
20,5 [1.25]	15°
25,7 [1.57]	18°
28 [1.71]	18,5°

Control shaft torque at 3000 rpm

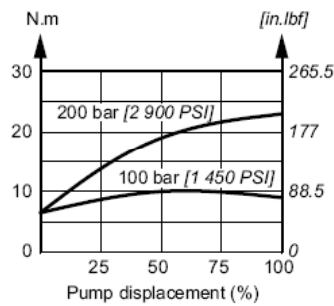

Control shaft torque at 1500 rpm

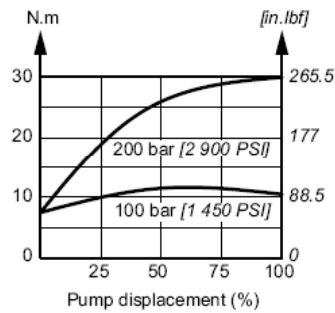

The spring return feature in the control unit is not a safety device.



Dimensions

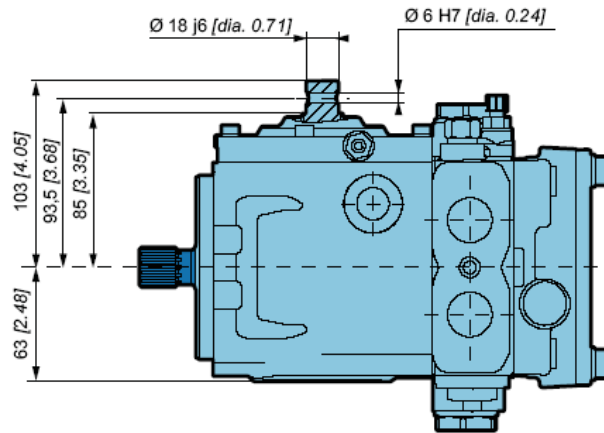

See page 7 for other dimensions
and port characteristics.

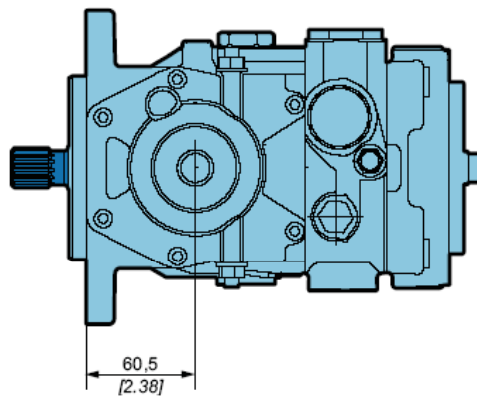

Mechanical servo control with feed back



The variation in pump displacement is obtained by rotating the drive lever situated on the servo control. An internal channel, linked to the charge pump, feeds a hydraulic servo valve which supplies oil into the cylinder which is in turn linked to the pump swashplate. The maximum rotation of the lever, with respect to 0 is 42,5° for both rotation directions; thus permitting the optimum control of the displacement.

At every lever angle there is a corresponding pump displacement. On the (T) return "arm" of the rotating distributor a restrictor (Rs) is mounted which regulates the servo control shifting speed, thus avoiding sudden accelerations and stoppages.

The effort of moving the lever is independent of the pressure and rpm.

Flow rate determination

Rotation	Control	Output	Input
Clockwise (R)	X	A	B
	Y	B	A
Counter clockwise (L)	X	B	A
	Y	A	B

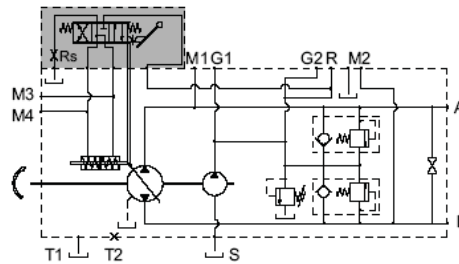

To prevent damage to the control A a positive mechanical stop must be provided for the control A linkage.

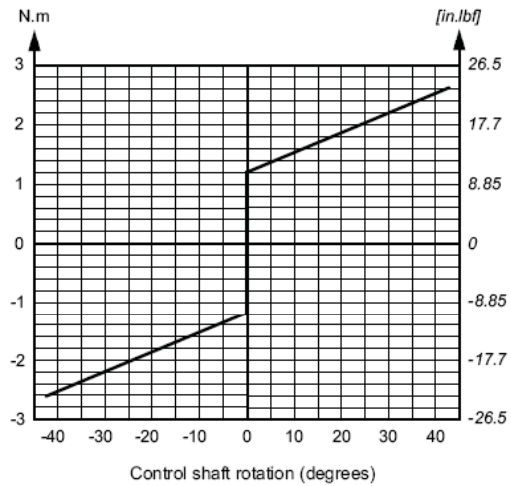
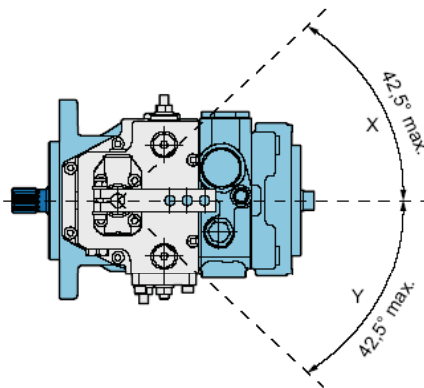

The spring return feature in the control unit is not a safety device.



Dimensions

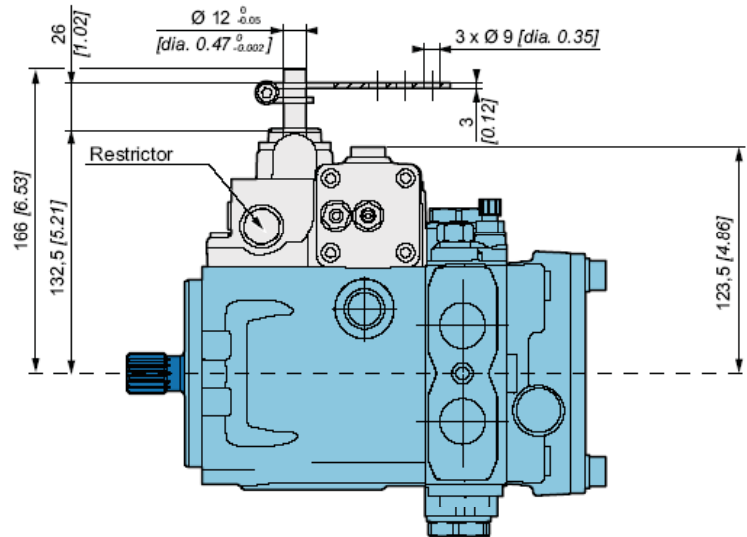

See page 7 for other dimensions and port characteristics.

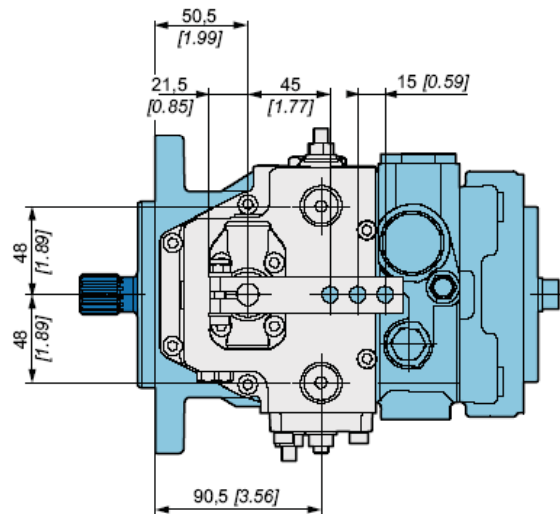

Hydraulic servo control



The variation in pump displacement is obtained by adjusting the pressure on the M3 and M4 servo control connections by means of a hydraulic proportional joystick (containing pressure reduction valves).

The joystick supply can be obtained by taking pressure from the auxiliary pump (G connection).

The servo control response time can be adjusted by inserting a restrictor on the joystick supply line (from 0.6 to 1,2 mm [from 0.02 to 0.05 in] or between the joystick and servo piston of the pump).

The servo control operation curve in both control directions goes from 6 to 15 bar [from 87 to 217 PSI]. The adjustment curve of the hydraulic control system has to be wider (from 5 to 16 bar [from 72.5 to 232 PSI]).

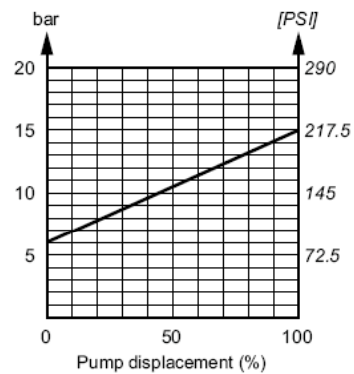
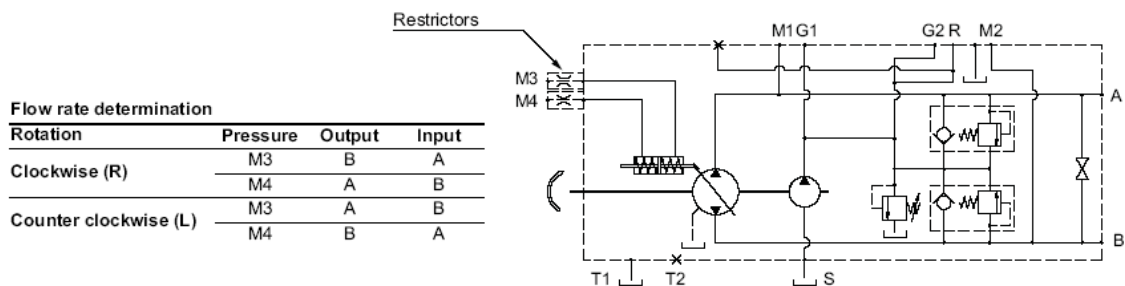

The spring return feature in the control unit is not a safety device.



Dimensions

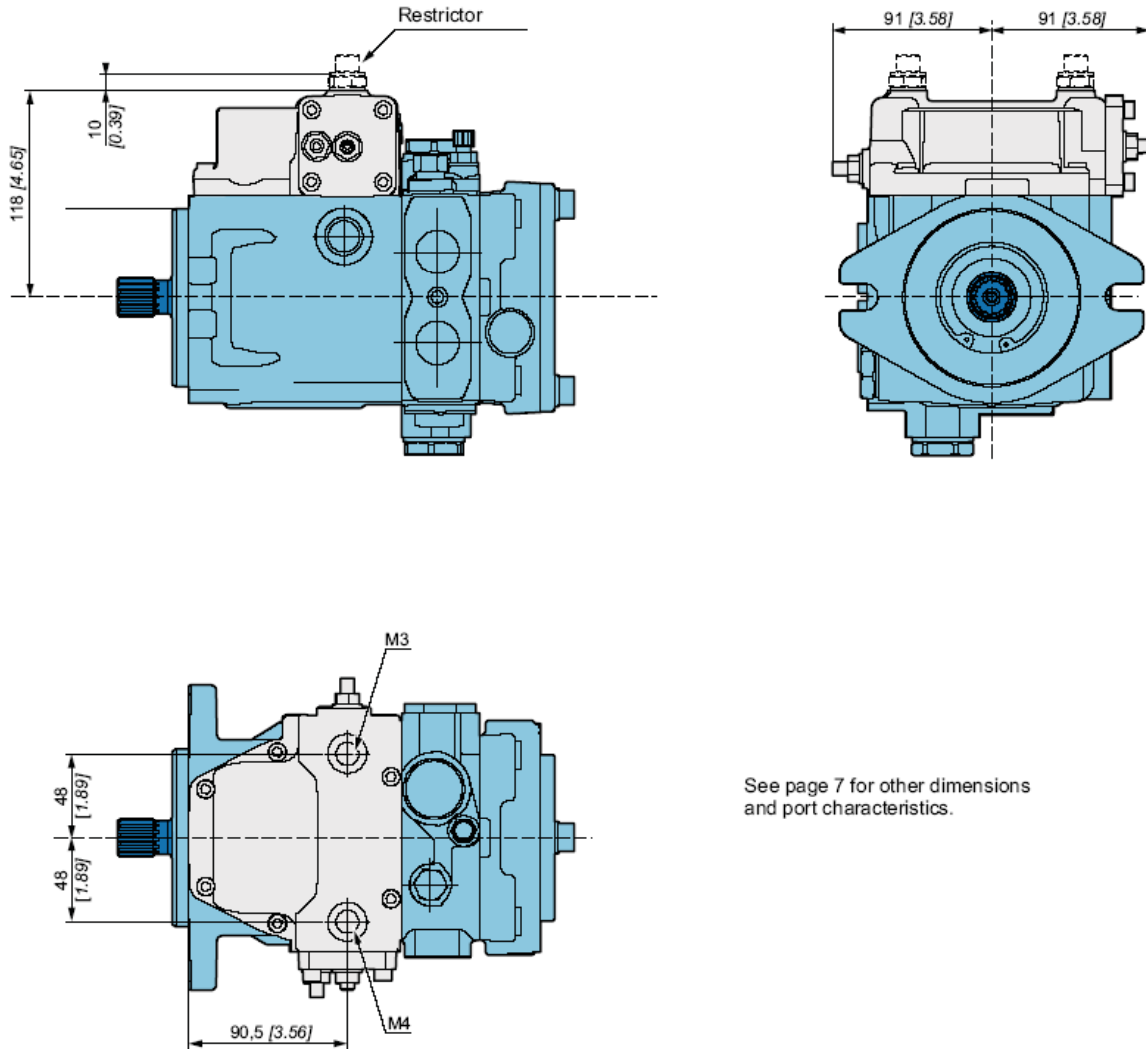

See page 7 for other dimensions and port characteristics.

Electrical on-off servo control

Control with return spring



The reaching of the maximum displacement in a time defined by the restrictors (Rs) which are positioned between the electrovalve and the (T) drain is obtained by the continuous starting of an ON-OFF electrovalve with an open-circuit CETOP 3 connection.

If the electro-valve motion is stopped, the pump goes back to "0" position thanks to the servo control springs.

The pump can be supplied either without electrovalve (B00) or with electrovalve (B12, B24).

Supply voltage

Without	B00
12V	B12
24V	B24

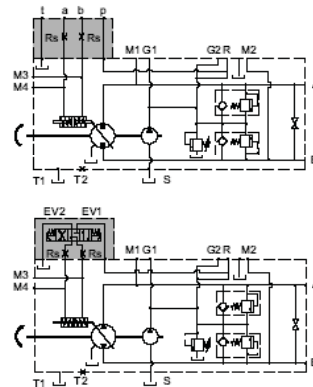

Control without return spring



The variation in pump displacement is obtained by the energizing of an ON-OFF electrovalve with a closed center CETOP 3 connection.

The displacement reached is in relation to the starting time of the electro-valve and to the diameter of the restrictors (Rs) which are placed between the electrovalve and the drain (T).

The pump can be supplied either without electrovalve (C00) or with electrovalve (C12, C24).

The servo control is without springs and the setting of the pump at a certain displacement is guaranteed by the closed center of the electrovalve.

Supply voltage

Without	C00
12V	C12
24V	C24

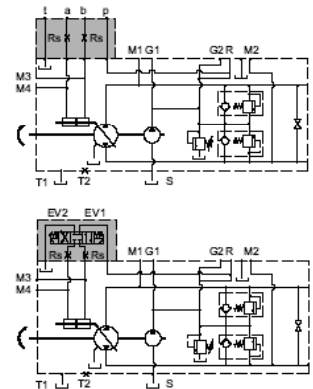

Flow rate determination

Rotation	Control	Pressure	Output	Input
Clockwise (R)	EV1	A	A	B
	EV2	B	B	A
Counter clockwise (L)	EV1	A	B	A
	EV2	B	A	B



The spring return feature in the control unit is not a safety device.



Dimensions

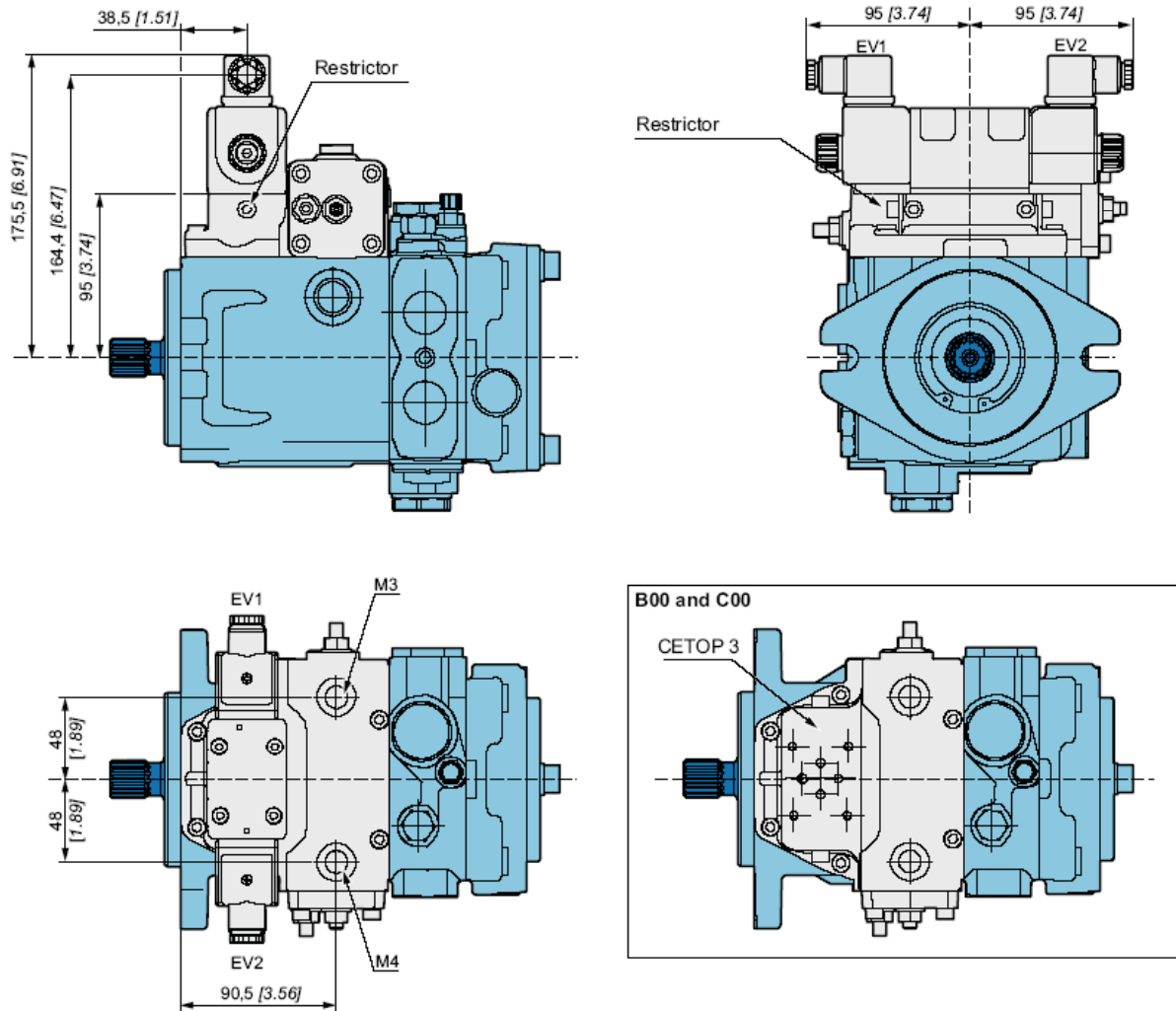

Type of connector: DIN 43650

See page 7 for other dimensions and port characteristics.

Electrico-proportional servo control



By means of a potentiometer and a control card, a voltage signal is applied to the proportional electrovalve coils which adjust the pressure of the servo control connected to the pump swashplate.

At every position of the potentiometer lever, there is a corresponding swashplate position.

The flow rate direction depends on which coil is excited.

The adjustment speed can be controlled by ramps installed on the card and by restrictors (Rs) positioned between the electrovalve and the servo control.

Supply voltage

12V	P12
24V	P24

Flow rate determination

Rotation	Pressure	Output	Input
Clockwise (R)	EP1	B	A
	EP2	A	B
Counter clockwise (L)	EP1	A	B
	EP2	B	A

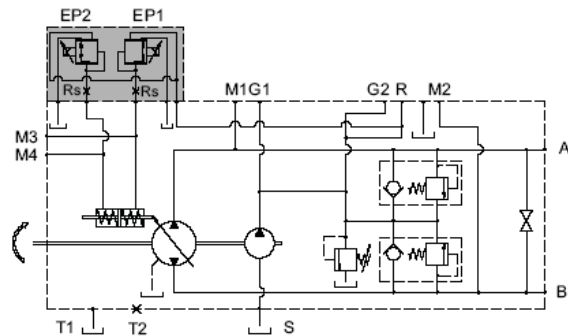

The current must not exceed 1500 mA under 12V and 800 mA under 24V.

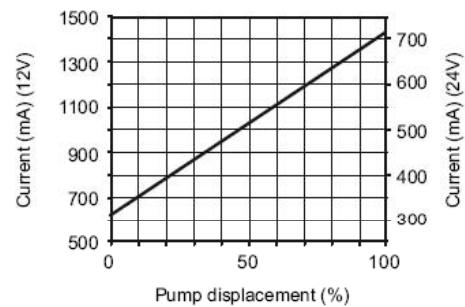

The spring return feature in the control unit is not a safety device.



Dimensions

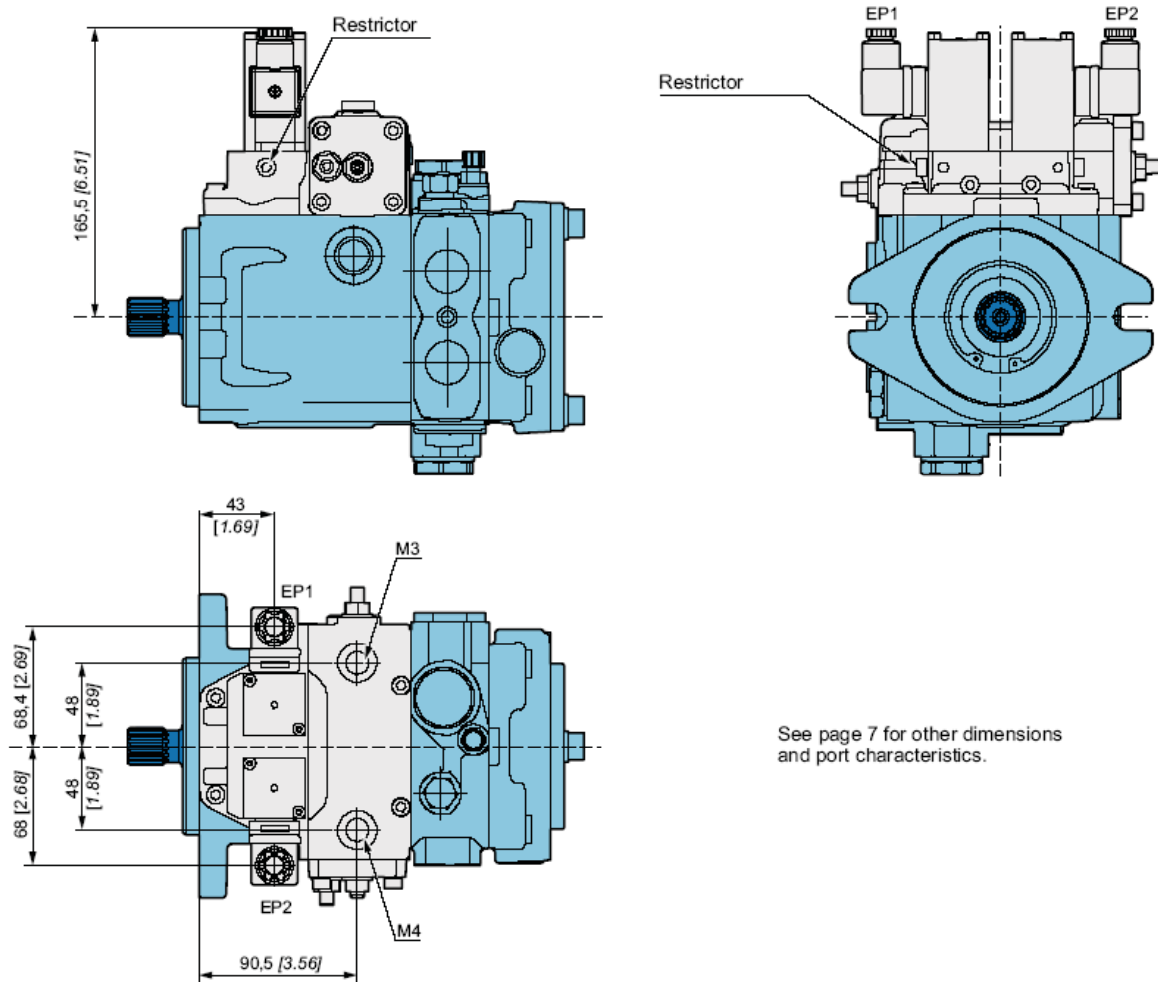

See page 7 for other dimensions and port characteristics.

Type of connector: DIN 43650

Hydraulic automotive control



In relation to the input rotation rate, the pump swashplate positioning cylinder is actuated by the pressure of the adjustment valve and a 4/3 electro-hydraulic valve, progressively positioning the swashplate. This provides a continuously variable pump displacement. The direction of the supplied flow is determined by which of the two solenoids is energized. The pilot pressure increases proportionally to the rotation rate. A pump displacement increase corresponds to the higher pilot pressure. In case the prime mover is overloaded, the rotation rate decreases and the pilot pressure is reduced causing a pump displacement reduction with a corresponding drop in absorbed power. An "Inching" lever (option IC) is available to reduce the pilot pressure independently of the pump rotation speed.

Supply voltage	
12V	D12
24V	D24

Flow rate determination

Rotation	Pressure	Output	Input
Clockwise (R)	E1	B	A
	E2	A	B
Counter clockwise (L)	E1	A	B
	E2	B	A

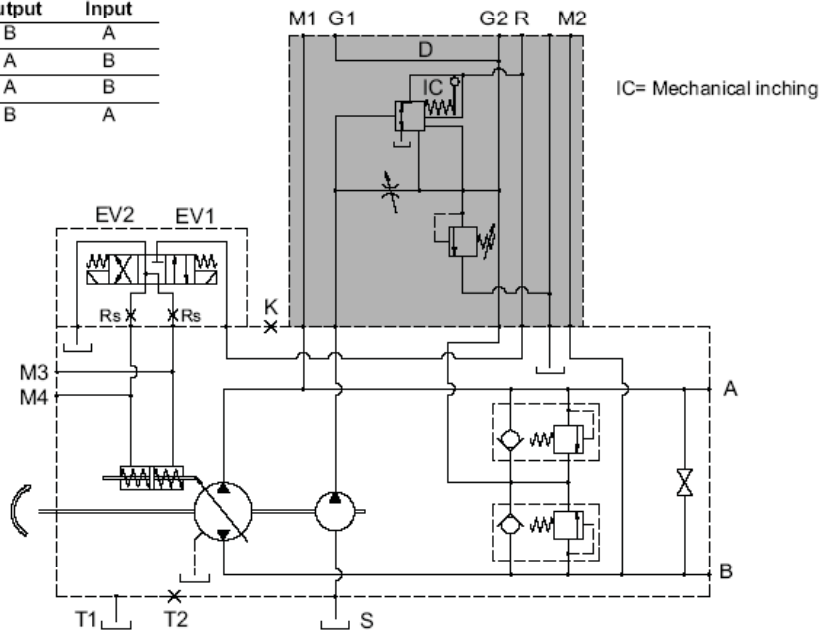

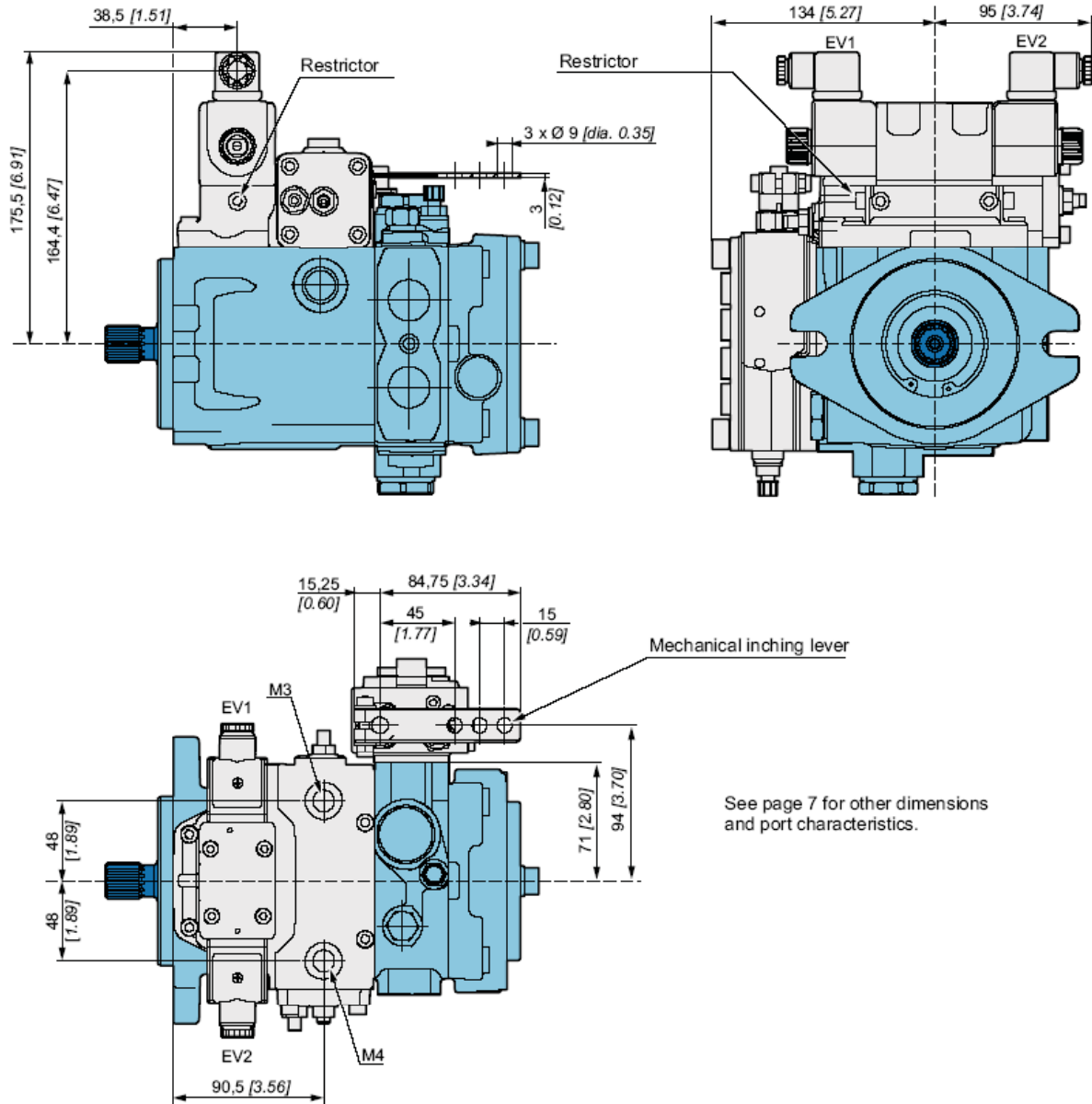
Dimensions with option IC

OPTIONS

Roller bearing



It is an optional high capacity bearing.

Depending on the characteristics of shaft load, the duty cycle of the application and the expected life time of your application, Roller bearing might be needed.

Consult your Poclairn Hydraulics Application Engineer.

Fluorinated elastomer seals



Standard NBR sealing are designed to resist to temperature up to 90°C [194°F] and to HV type oils.

If your application is outside these limits, Fluorinated elastomer seals might be recommended.

Consult your Poclairn Hydraulics Application Engineer.

UNF threads ports

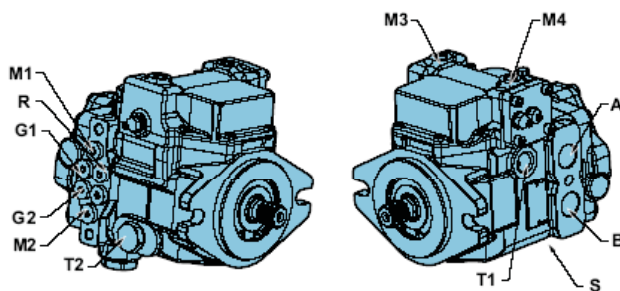

Port	Function	ISO 11926-1
A-B	Services	1 1/6-12-UNF
G	Auxiliary	9/16-18-UNF
M1/M2	Gauge	9/16-18-UNF
M3/M4	Servo control pilot	9/16-18-UNF
S	Suction	1 1/6-12-UNF
T1/T2	Drain	3/4-16-UNF

Filter on pressure line

The PM25 pumps can have a pressure filter without clogging indicator (F0) or with clogging indicator (F2). The flow thru the filter is only the flow that entry in the close loop. The filter fitness is of 10 micron.

Maximum pressure difference between filter cartridge input and output is 2 bar [29 PSI]. When reaching 2 bar [29 PSI], the cartridge has to be changed.

The max. working pressure is 30 bar [435 PSI].

Tightening torque: 35 Nm [309 in.lbf].

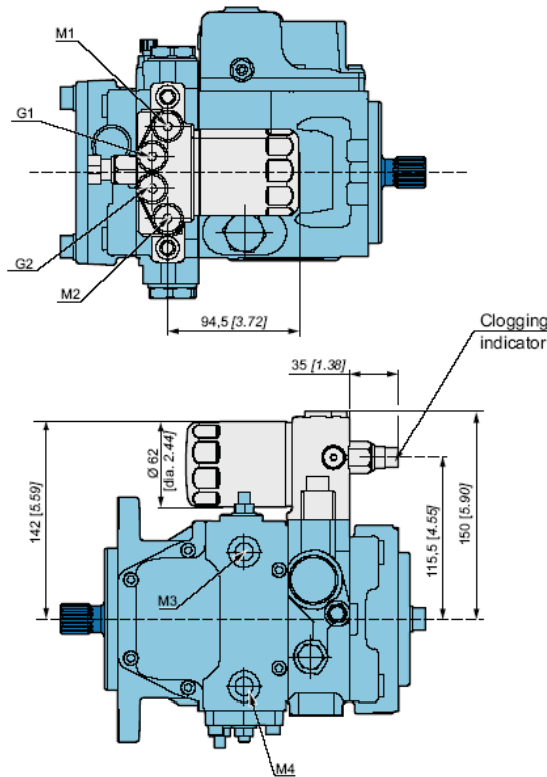
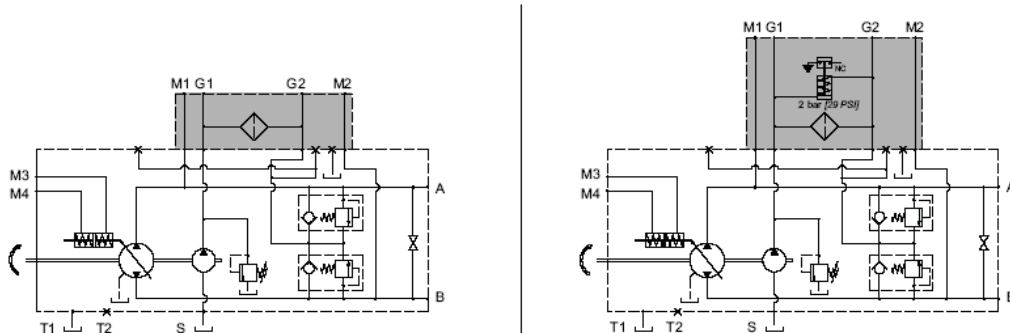
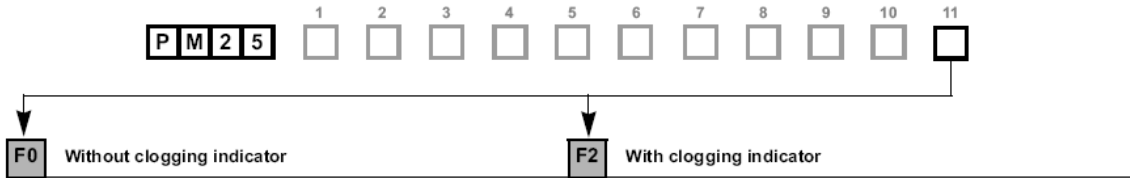

Pressure cut-off valve



The function of the cut-off valve is to avoid that the pump absorbed power exceeds the machine engine power.

The cut-off valve is connected to A and B piston pump's high pressure lines and is usually set at 20 to 30 bar [290 to 435 PSI] lower than the maximum relief valve of the closed circuit.

The cut-off valve acts on the servo control operating pressure in order to reduce the pump displacement and the adsorbed power.

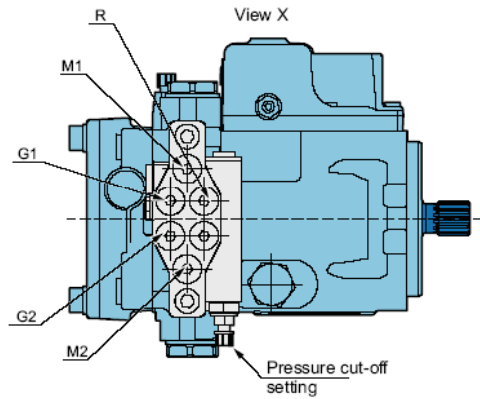
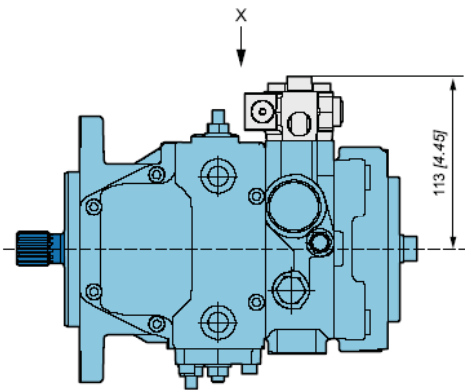
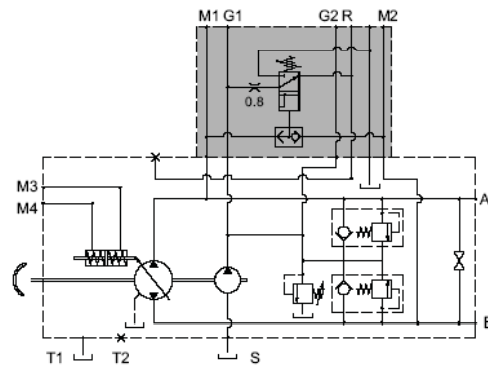

Mechanical inching



For hydraulic automotive control D. An "Inching" lever is available to reduce the pilot pressure independently of the pump rotation speed. See Hydraulic automotive control (D) page 36.



Neutral position switch



For the control A it is possible to obtain a micro switch to avoid the start of the engine if the lever of the control is not in center (zero position).

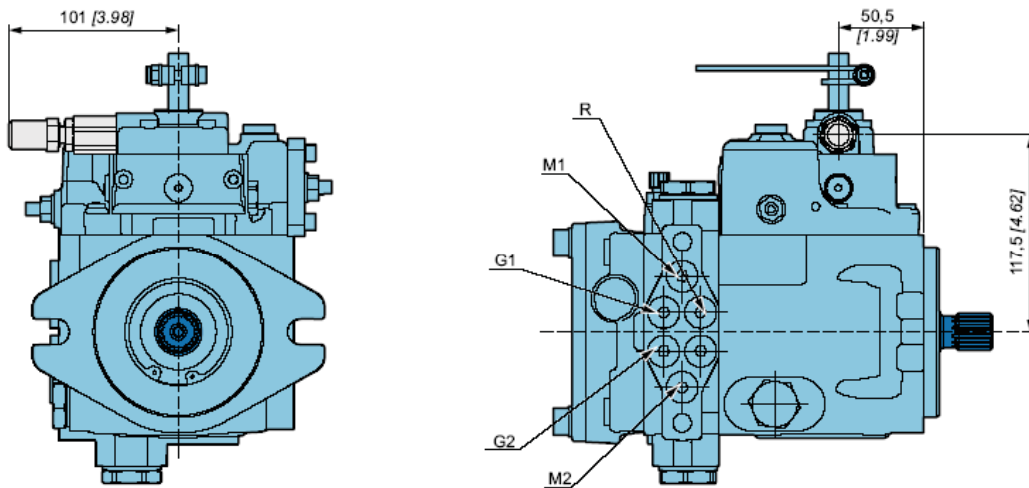
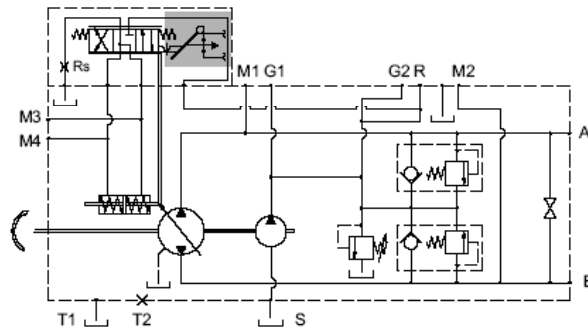

Type of connector: Deutsch DT04-2P

Flushing valve



Inside the pump cover, a purge valve can be fitted with discharge inside the pump casing by means of a calibrated hole. The exchange valve is useful in case the temperature of the oil in the closed circuit is too high.

