



PM10 PUMPS



PM10 – 18. HYDRAULIC PUMPS.

OVERVIEW

PM10 is a variable displacement, axial piston pump, with swashplate system, for closed loop hydrostatic transmissions.

It provides a continuously variable flow rate between zero and maximum in forward and reverse direction. Flow rate is proportional to rotation speed and swashplate angle.

It can feature a charge pump to keep the circuit pressurised. This avoids risk of cavitations and ensures a good performance of the transmission.

It offers several types of control: direct mechanical, servo hydraulic, servo mechanical, electrical and proportional electrical.

It is equipped with high pressure relief valves and can be delivered with auxiliary gear pumps.

It is available in single or tandem versions.

As options, PM10 can be featured with flushing valve, filter on charge pressure line and safety devices to ensure safe operation of the machine.

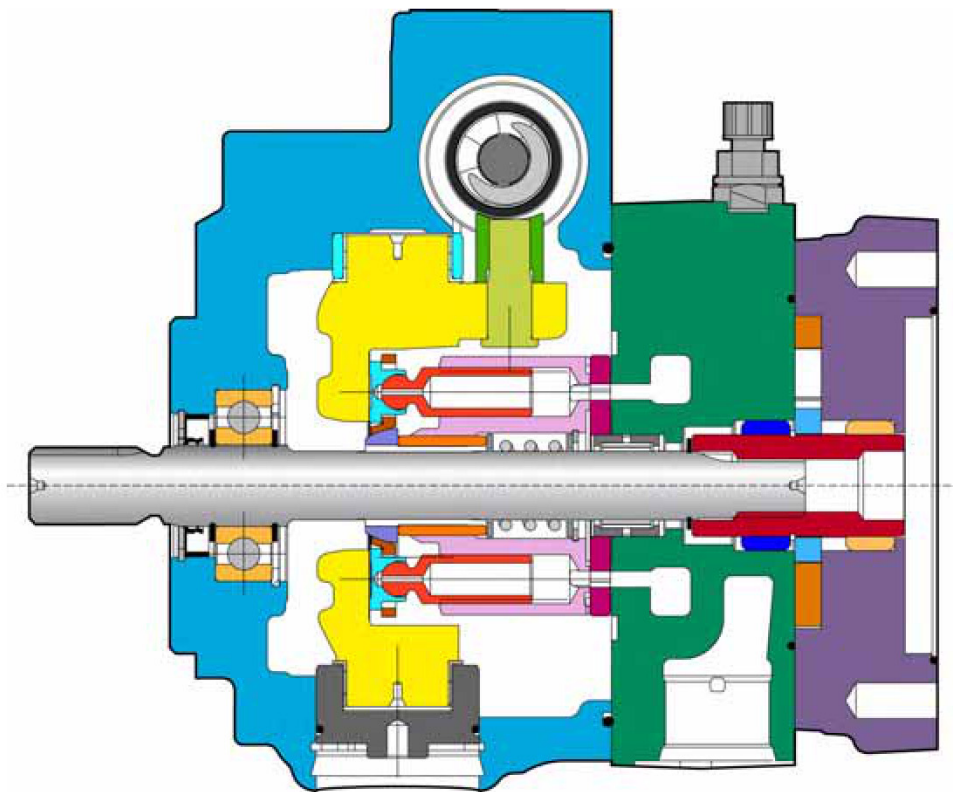

		PM10-07	PM10-09	PM10-11	PM10-14	PM10-18	PM10-21
Displacement	cm ³ /rev [in ³ /rev.]	7,08 [0.43]	9,08 [0.55]	11,83 [0.72]	14,32 [0.87]	17,85 [1.09]	20,40 [1.24]
Theoretical Flow at rated speed	L/min [GPM]	25,5 [6.74]	32,7 [8.64]	42,6 [11.25]	51,6 [13.63]	64,3 [16.99]	73 [19.28]
Rated speed	rpm	3 600					
Rated pressure	bar [PSI]	210 [3 045]					
Max. pressure	bar [PSI]	350 [5 076]					300 [4 351]
Mounting flange		SAE A, SAE B					
Controls		Direct mechanical, servo hydraulic, servo mechanical, electrical, electrico-proportional, automotive					
Mass	kg [lb]	from 16,3 [35.9] to 18,8 [41.4]					
Rotation		Clockwise or Counterclockwise					

CONTENT

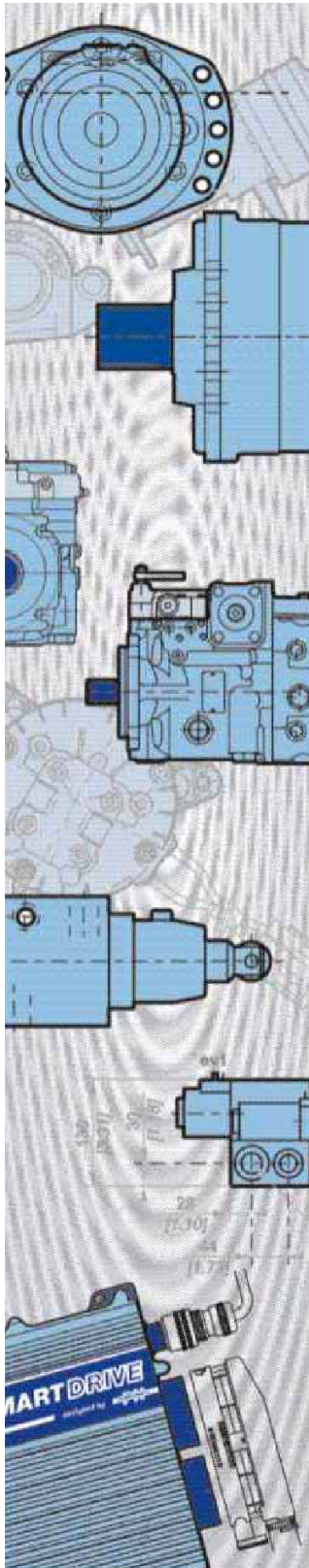

MODEL CODE	4	Model Code
TECHNICAL SPECIFICATIONS	6	Technical specifications
Features	6	
Performances	6	
Main dimensions	7	
Port characteristics	7	
OPERATING PARAMETERS	9	Operating Parameters
Operating parameters	9	
Charge pressure	9	
Case pressure	9	
Pressure ratings	9	
Speed ratings	9	
Inlet pressure	10	
Theoretical output	10	
Poclairn Hydraulics recommendations for fluid	10	
Fluid and filtration	11	
Viscosity range	11	
SYSTEM DESIGN PARAMETERS	12	System design Parameters
Sizing equations	12	
Redundant braking system requirement	12	
Loop flushing	12	
Reservoir	13	
Case drain usage for tandem pump	13	
Differential pressure	13	
Bearing life and external shaft loading	14	
Hydraulic unit life	15	
Mounting flange loads	15	
FEATURES	16	Features
High pressure relief valve	16	
Charge relief valve	17	
Charge pump	18	
Displacement limiters	19	
By-pass	19	
Mounting flange and shafts	20	
Auxiliary mounting pad	22	
Tandem pumps	25	
Gear pumps	27	
CONTROLS	28	Controls
Direct mechanical controls	28	
Hydraulic servo control	30	
Mechanical servo control with feed back	32	
Electrical on-off servo control	34	
Electrico-proportional servo control	36	
Hydraulic automotive control	38	
OPTIONS	41	Options
Roller bearing	41	
Fluorinated elastomer seals	41	
UNF threads ports	41	
Filter on pressure line	42	
Neutral position switch	43	
Safety valve	44	
Flushing valve	46	
Mechanical inching	46	

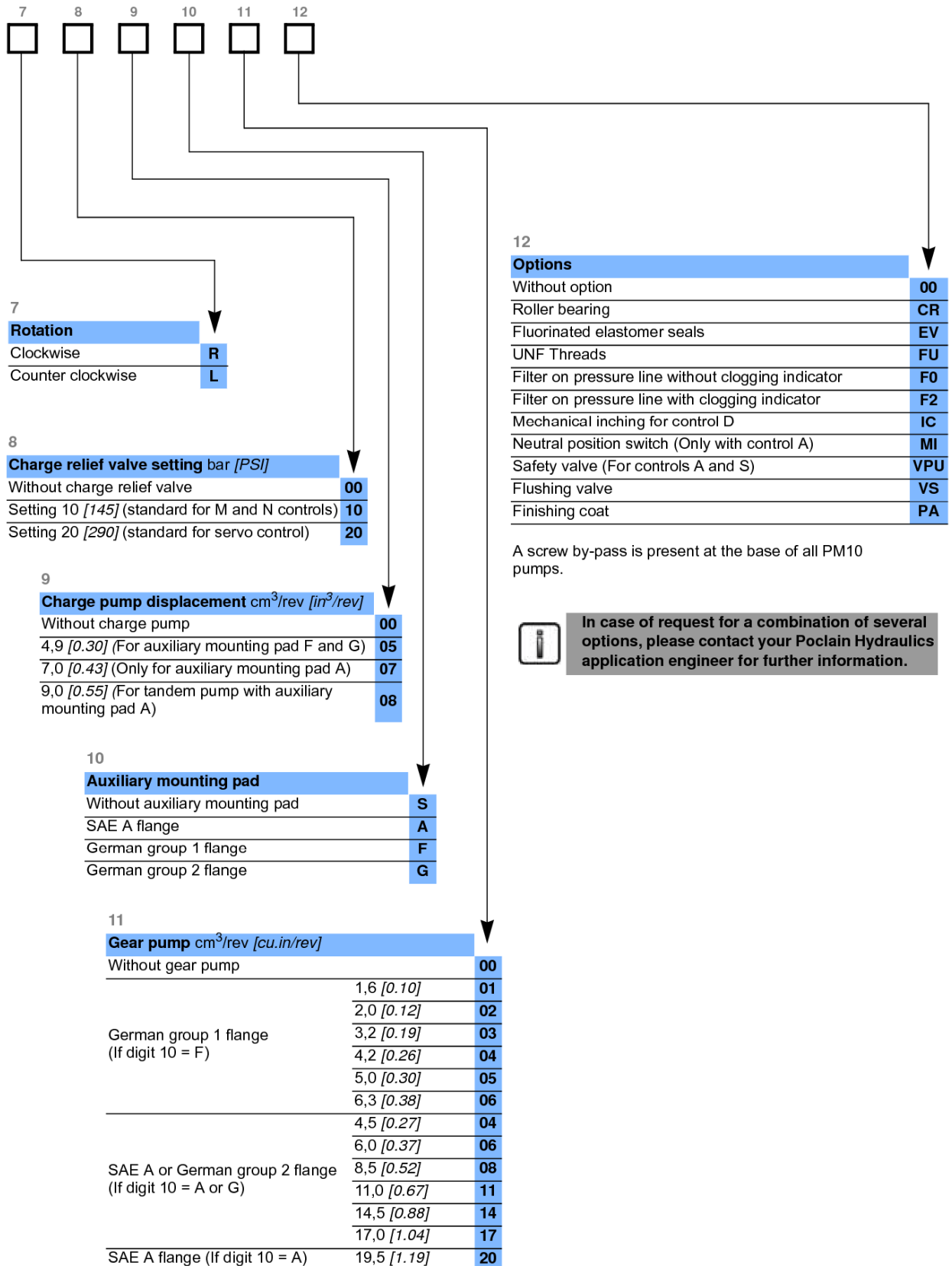

TECHNICAL SPECIFICATIONS

Features

		PM10-07	PM10-09	PM10-11	PM10-14	PM10-18	PM10-21	
Displacement	cm ³ /rev [in ³ /rev.]	7,08 [0.43]	9,08 [0.55]	11,83 [0.72]	14,32 [0.87]	17,85 [1.09]	20,40 [1.24]	
Theoretical flow at rated speed (3600 rpm)	L/min [GPM]	25,5 [6.74]	32,7 [8.64]	42,6 [11.25]	51,6 [13.63]	64,3 [16.99]	73 [19.28]	
Max. Theoretical absorbed power	KW	14,9	19,1	24,8	30,1	35,3	42,6	
Theoretical absorbed torque at 100 bar [1 450 PSI]	N.m [in.lbf]	11,3 [100]	14,5 [128]	18,8 [166]	22,8 [202]	28,4 [251]	32,3 [286]	
Moment of inertia	kg.m ² [slug.ft ²]			0,0014 [0.0010]				
Internal charge pump	cm ³ /rev [in ³ /rev]		4,9 [0.30]; 7,0 [0.43] or 9,0 [0.55]					
Charge relief valve setting	bar [PSI]		From 6 [87] to 30 [435]*					
High pressure relief setting	bar [PSI]		Max. 350 [5 076]					Max. 300 [4 351]
Mounting flange			SAE A, SAE B					
Mass	kg [lb]		16,3 [35.9] with control M, N, S 18,8 [41.4] with controls A, B, C, D, P					
Noise level	dBA		< 75					

* 30 bar [435 PSI] only at maximum revolutions.

Performances

Volumetric and total efficiency curves

Oil ISO VG46, temperature = 50°C [122 °F].

Pump displacement = 17.85 cm³/rev. [1.09 in³/rev.].

Charge pressure 20 bar [290 PSI].

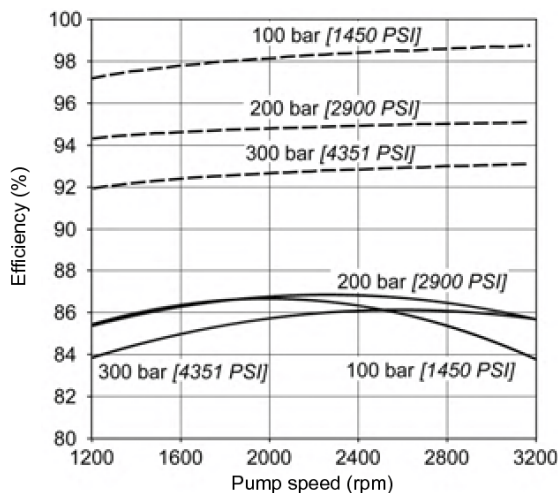

--- Volumetric efficiency
— Total efficiency

Overall efficiency curve

Oil ISO VG46, temperature = 50°C [122 °F].

Pump displacement = 17.85 cm³/rev. [1.09 in³/rev.].

Charge pressure 20 bar [290 PSI].

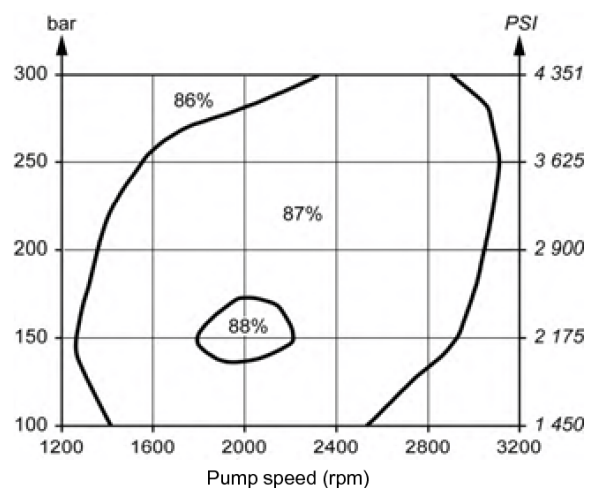

Main dimensions

PM10 with hydraulic servo control and without auxiliary mounting pad.

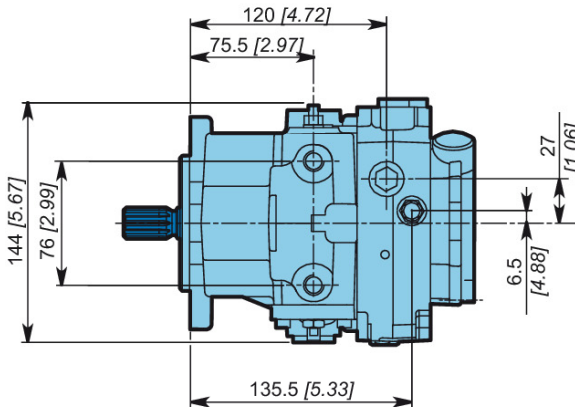
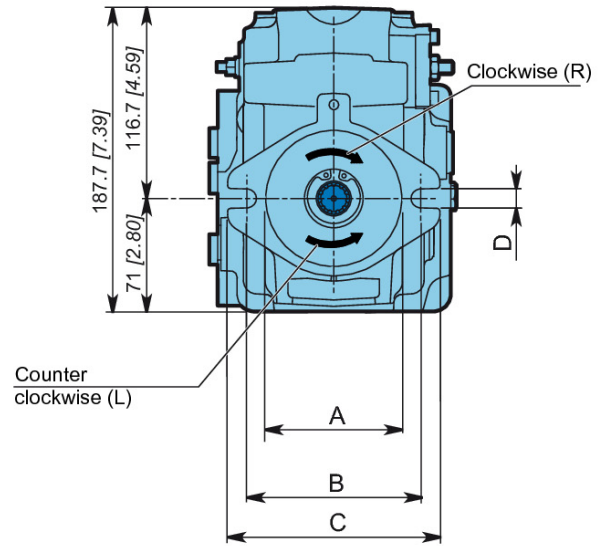
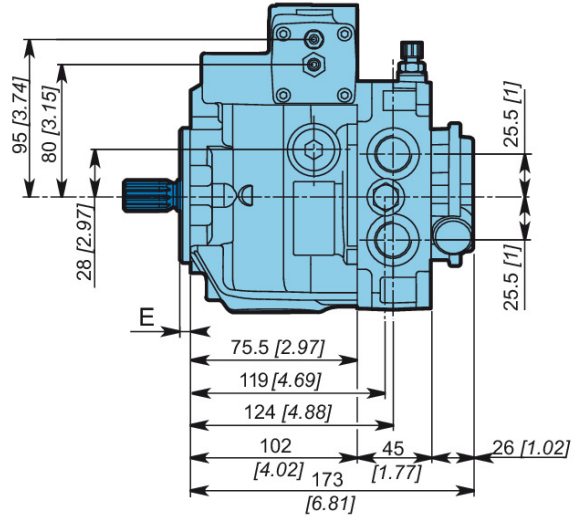

	SAE A	SAE B
A	Ø 82,55 h8 ⁰ _{-0.054} [dia. 3.25 h8 ⁰ _{-0.002}]	Ø 101,6 ⁰ _{-0.05} [dia. 4.00 ⁰ _{-0.002}]
B	106 [4.17]	146 [5.75]
C	130 [5.12]	174 [6.85]
D	Ø 11,6 [dia. 0.46]	Ø 14,3 [dia. 0.56]
E	6,4 [0.25]	9,7 [0.38]

See from page 28 to page 37 for control dimensions.

Port characteristics

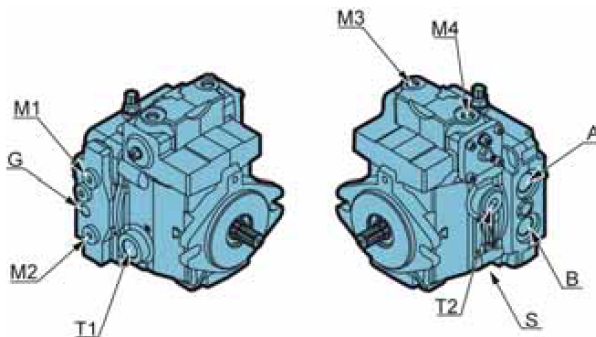

Port	Function	ISO 1179-1 (standard)	ISO 11926-1 (option FU)
A-B	Services	1/2" GAS	3/4-16 UNF-2B
G	Auxiliary	1/4" GAS	7/16-20 UNF-2B
M1/M2	Gauge	1/4" GAS	7/16-20 UNF-2B
M3/M4	Servo control pilot	1/8" GAS	7/16-20 UNF-2B
S	Suction	3/4" GAS	1-1/16-12 UNF-2B
T1/T2	Drain	1/2" GAS	7/8-14 UNF-2B

OPERATING PARAMETERS

Operating parameters

		PM10-07	PM10-09	PM10-11	PM10-14	PM10-18	PM10-21
Speed ratings	Minimum				700		
	Max. without load				3 900		
	Max. with load				3 600		
System pressure	Rated				210 [3 045]		
	Maximum				350 [5 076]		300 [4 351]
	Minimum low loop				6 [87]		
Inlet pressure	Mini continuous				0,8 [11.6]		
	Mini (cold start)				0,5 [7.2]		
Case pressure	Continuous				1,5 [21.7]		
	Maximum (cold start)				2,5 [36.2]		
Charge pressure	Standard for M / N controls				10 [145]		
	Standard version				20 [290]		
	Max. charge pressure				30 [435] (only at maximum revolutions)		

Charge pressure

A charge flow is required to maintain a positive pressure in the low pressure loop of a closed loop hydrostatic transmission. Charge pressure ensures proper lubrication and rotating group operation. It is recommended to maintain the charge pressure at a minimum of 6 bar [87 psi] above case pressure. For more details, refer to charge pump paragraph, page 18.

Case pressure

Case pressure must be maintained within the limits shown in the table "Operating parameters". Ensure housing is always filled with hydraulic fluid and especially during start-up of the machine.

Pressure ratings

Maximum peak pressure

It is the maximum allowable pressure. It is equivalent to the maximum setting of the maximum high pressure relief valve. A self-propelled machine can reach the maximum peak pressure value no more than 1-2% of that work cycle.

Work cycle

A fundamental factor for ensuring correct hydrostatic transmission sizing is the machine work cycle (pressure-time ratio, seasonality, pressure vs. percentage of time at max. displacement, machine type). Part service life depends on the correct choice in relation to the work cycle.

Overloads

It is mandatory to protect parts against any possible overloads.

Speed ratings

The table "Operating parameters" gives minimum and maximum rated speeds. Note that all displacements might operate under different speed limits. Definitions of these speed limits appear below.

Maximum speed is the highest operating speed allowed. Over speeding reduces pump life time, can lead to loss of hydrostatic power and braking capacity. Never exceed the maximum speed limit under any operating conditions.

Nominal speed is the speed offering the maximal efficiency.

Inlet pressure

Charge pump inlet pressure is key for acceptable pump life and performances. A continuous inlet pressure of not less than 0,8 bar abs. [11.6 PSI abs.] is recommended. An continuous inlet pressure less than 0.5 bar abs. [7.2 PSI abs.] indicates inadequate inlet design or a restricted filter. Pressures less than 0.5 bar abs. [7.2 PSI abs.] can happen at cold start, but should increase with oil temperature.

Theoretical output

Theoretical output flow is a function of pump displacement and speed. It is relevant to size the rest of the circuit. Theoretical flow does not take into account losses due to leakage or variations in displacement. Refer to performances, page 6, for volumetric and overall efficiencies at various operating speeds and pressures.

Poclairn Hydraulics recommendations for fluid



Poclairn hydraulics recommends the use of hydraulic fluids defined by the ISO 12380 and ISO 6743-4 standards. For temperate climates, the following types are recommended.

- HM 46 or HM 68 for fixed installations.
- HV 46 or HV 68 for mobile installations.
- HEES 46 for mobile installations.

These specifications correspond to category 91H of the CETOP standard, parts 1, 2 and 3 of the DIN 51524 standard, and grades VG32, VG 46 and VG68 of the ISO 6743-4 standards.



It is also possible to use ATF, HD, HFB, HFC or HFD type hydraulic fluid upon Poclairn Hydraulics specific approval of the components' operating conditions.

Standardized designations for the fluids

- **HM** : Mineral fluids having specific antioxidant, anticorrosion and antiwear properties (HLP equivalent to DIN 51524 parts 1 and 2).
- **HV** : HM mineral fluids providing improved temperature and viscosity properties (DIN 51524 part 3).
- **HEES** : Biodegradable fluids based on organic esters.



It is also possible to use a fluid that meets the biodegradability criteria and is compatible in the event of accidental food contact. The BIOHYDRAN FG 46 fluid designed by the company Total has undergone testing of its properties and performance on our test benches. Since this type of fluid has not yet been categorized, it is the responsibility of machine manufacturers to validate its compatibility with all of the components used in order to guarantee that the intended functions will be fulfilled and this for the desired life time of all equipment items.



For biodegradable fluids, consult your Poclairn Hydraulics' application engineer



During operation, the temperature of the oil must be between 0°C [32°F] and 80°C [176°F]; the minimum and maximum temperatures may be exceeded momentarily by ± 20°C [± 68°F] for a duration of less than 30 minutes. For all applications outside these limits, please consult with your Poclairn Hydraulics' application engineer.

Fluid and filtration

The contaminating particles suspended in the hydraulic fluid cause the hydraulic mechanisms moving part wear. On hydraulic pumps, these parts operate with very small dimensional tolerances. In order to reach the part life, it is recommended to use a filter that maintains the hydraulic fluid contamination class at a max. of:

- 9 according to NAS 1638
- 20/18/15 according to ISO 4406:1999

According to the type of application decided for the pump, it is necessary to use filtration elements with a filtration ratio of:

$$\beta_{20 \text{ to } 30} \geq 100$$

Making sure that this ratio does not worsen together with the increasing of the filter cartridge differential pressure.

If these values cannot be observed, the component life will consequently be reduced and it is recommended to contact the Poclair Hydraulics Customer Service.

Filters on charge circuit

Filters on the charge circuit (F0-F2) are designed without by-pass. The max. pressure drop on the filtration part must not exceed 2 bar [29 PSI] (3 bar [43.5 PSI] in case of cold starting) at pump full rating. To monitor the pressure drop, It is recommended to use the clogging indicator on the filtration element (F2 option). Contact your Poclair Hydraulics Application engineer, each time the pump is not charged by its internal charge pump.

Filters on charge circuit are mounted on the pump special support.

Filters assembling

The suction filter is mounted on the suction line. Check that the pressure before the charge pump is 0.8 bar abs. [11.6 PSI abs.], measured on the pump suction port (0.5 bar [7.2 PSI] for cold starting).

Viscosity range

For both max. efficiency and life of the unit, the operative viscosity should be chosen within the optimum range of:
 $\sqrt{\text{opt}}$ = optimum operating viscosity from 16 to 36 mm²/s [from 74.1 to 166.8 SUS] referred to the closed loop temperature.

Working conditions: the following limits of viscosity apply

$\sqrt{\text{min}}$ = 5 mm²/s [23 SUS] short-duration at a max. permissible leakage oil temperature of 90° C [194 °F]

$\sqrt{\text{max}}$ = 1000 mm²/s [4 634 SUS] short-duration, on cold start.

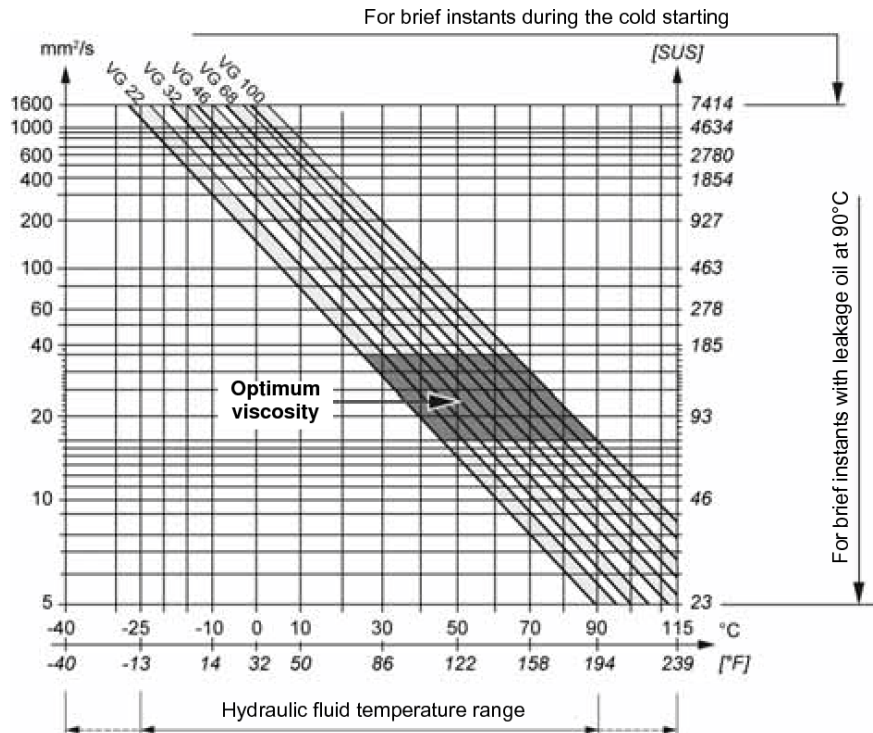

Ensure fluid temperature and viscosity limits are concurrently satisfied.



SYSTEM DESIGN PARAMETERS



Consult your Poclairn Hydraulics application engineer to validate your design parameters before using the pump in your application.

Sizing equations

The following equations are helpful when sizing hydraulic pumps. Generally, the sizing process is initiated by an evaluation of the machine system to determine the required motor speed and torque to perform the necessary work function. First, the motor is sized to transmit the maximum required torque. The pump is then selected as a flow source to achieve the maximum motor speed.

	Output flow Q	$= \frac{V_g \cdot n \cdot \eta_v}{1000}$	(l/min)
SI units	Input torque M	$= \frac{V_g \cdot \Delta p}{20 \cdot \pi \cdot \eta_m}$	(N.m)
	Input power P	$= \frac{M \cdot n \cdot \pi}{30\,000} = \frac{Q \cdot \Delta p}{600 \cdot \eta_t}$	(kW)
	Output flow Q	$= \frac{V_g \cdot n \cdot \eta_v}{231}$	[GPM]
US units	Input torque M	$= \frac{V_g \cdot \Delta p}{2 \cdot \pi \cdot \eta_m}$	[lbf.in]
	Input power P	$= \frac{M \cdot n \cdot \pi}{198\,000} = \frac{Q \cdot \Delta p}{1714 \cdot \eta_t}$	[hp]

V_g = Displacement per revolution cm^3/tr [in^3/rev]
 $\Delta p = p_o - p_i$ (system pressure) bar [PSI]
 n = Speed min^{-1} [rpm]
 η_v = Volumetric efficiency
 η_m = Mechanical efficiency
 η_t = Overall efficiency = $\eta_v \times \eta_m$

Redundant braking system requirement



Unintended vehicle or machine movement hazard.
 The loss of hydrostatic drive line power, in any mode of operation (forward, neutral, or reverse) may cause the system to lose hydrostatic braking capacity. You must provide a braking system, redundant to the hydrostatic transmission, sufficient to stop and hold the vehicle or machine in the event of hydrostatic drive power loss.

Loop flushing

Closed circuit may require a flushing valve to meet temperature and cleanliness requirements. A flushing valve takes a part of hot fluid flow from the low pressure loop of the system loop for cooling and filtering. Make sure that the charge pump provides adequate flow for the flushing valve flushing and the flushing valve does not cause charge pressure to drop below recommended limits.

See option VS for more information

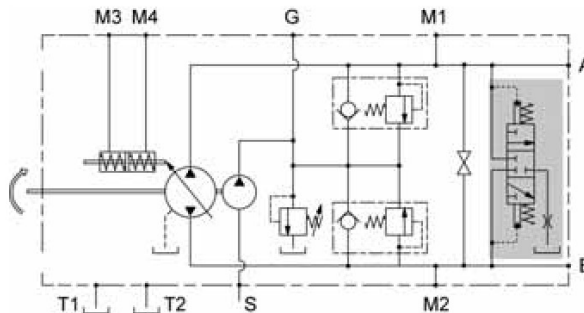

Reservoir

The reservoir provides clean fluid, dissipates heat, and removes entrained air from the hydraulic fluid. It allows for fluid volume changes associated with fluid expansion and cylinder differential volumes. Minimum reservoir capacity depends on the volume needed to perform these functions. Typically, a capacity of one half the charge pump flow (per minute) is satisfactory for a closed reservoir. Open circuit systems sharing a common reservoir require greater fluid capacity.

Locate the reservoir outlet (suction line) near the bottom, allowing clearance for settling foreign particles. Use a 100 - 125 µm screen covering the outlet port.

Place the reservoir inlet (return lines) below the lowest expected fluid level, as far away from the outlet as possible.

Use a baffle (or baffles) between the reservoir inlet and outlet ports to promote de-aeration and reduce fluid surging.

Case drain usage for tandem pump

On tandem pumps, and to ensure lubrication of both pumps, excess flow from the first pump charge relief valve must be routed into the housing of the second pump.

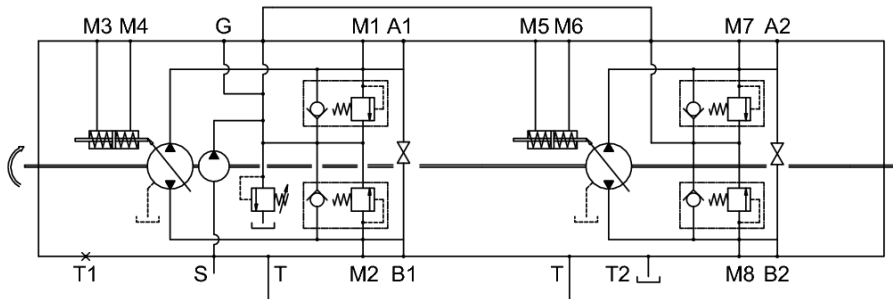

Differential pressure

The differential pressure is the High pressure relief valve setting minus Charge relief valve setting.

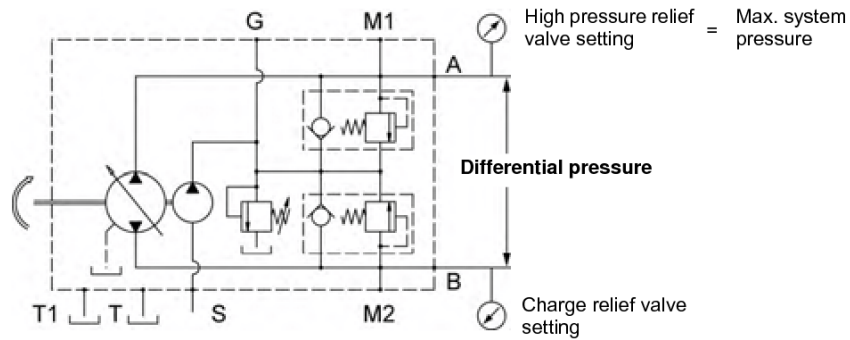

Bearing life and external shaft loading

Bearing life:

Bearing life is a function of speed, pressure, swashplate angle and external loads. Oil type and viscosity impact bearing life.

	PM10-07	PM10-09	PM10-11	PM10-14	PM10-18	PM10-21
Bearing life (B₁₀ hours)	76 105	36 062	16 294	9 204	4 743	3 178

Normal bearing life in B₁₀ hours is shown in the above table. Figures have been calculated under the following operating conditions :
 A continuous differential pressure of 120 bar [1740 PSI], 1800 rpm shaft speed, 20 bar [290 PSI] charge pressure, maximum displacement, without any external shaft side load. The data is based on a 50% forward, 50% reverse duty cycle, and standard charge pump size.

Shaft Loads

PM10 pumps are designed with bearings that can accept external radial and thrust loads. The external radial shaft load limits depend on the load position, orientation, and operating conditions of the unit.

The maximum permissible radial load (Re), is based on the maximum external moment (Me), and the distance (L) from the mounting flange to the load. It may be determined using the table and formula below. Thrust (axial) load limits are also shown.

$$Re = Me / L$$

All external shaft loads affect bearing life. In applications with external shaft loads, minimize the impact by positioning the load at 90° or 270° as shown in the figure.

Contact your Poclain Hydraulics representative for an evaluation of unit bearing life if:

- Continuously applied external loads exceed 25 % of the maximum allowable radial load Re.
- The pump swashplate is positioned on one side of center all or most of the time.
- The unit bearing life (B₁₀) is critical.

	PM10-07	PM10-09	PM10-11	PM10-14	PM10-18	PM10-21
External moment (Me) N.m [in.lbf]	63 [558]	59 [522]	52 [460]	46 [407]	38 [336]	32 [283]

at 120 bar [1740 PSI]

Radial and thrust load position

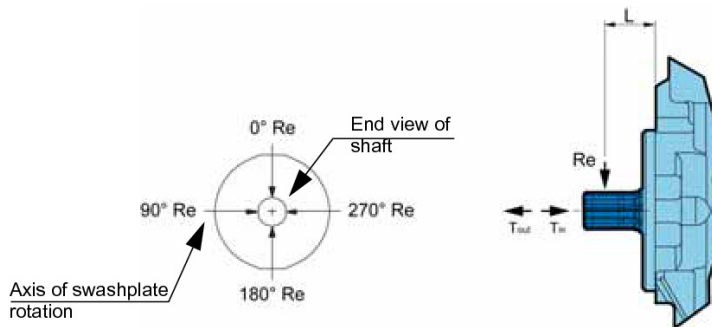

For an accurate calculation, consult your Poclain Hydraulics application engineer.

Hydraulic unit life

Hydraulic unit life is the life expectancy of the hydraulic components. It depends on speed and system pressure even if, system pressure is the dominant operating variable. High pressure, generated by high load, reduces hydraulic unit life.

Design the hydraulic system according to the expected machine duty cycle. Take in consideration the expected percentages of time at various loads and speeds. Ask your Poclain Hydraulics representative to calculate an appropriate pressure based your hydraulic system design. If duty cycle data is not available, input power and pump displacement are used to calculate system pressure.

All pressure limits are differential pressures (referenced to charge pressure), taking a normal charge pressure in consideration.

PM10 pumps will meet satisfactory life expectancy if applied within the parameters specified in this technical documentation. For more detailed information on hydraulic unit life see Operating Parameters in page 9.

Mounting flange loads

Adding tandem mounted pumps, and/or tandem auxiliary pump(s), subjecting pumps to shock loads may generate excessive loads on the front mounting flange. The overhung load moment for multiple pump mounting can be estimated as shown in the figure below

Overhung load example

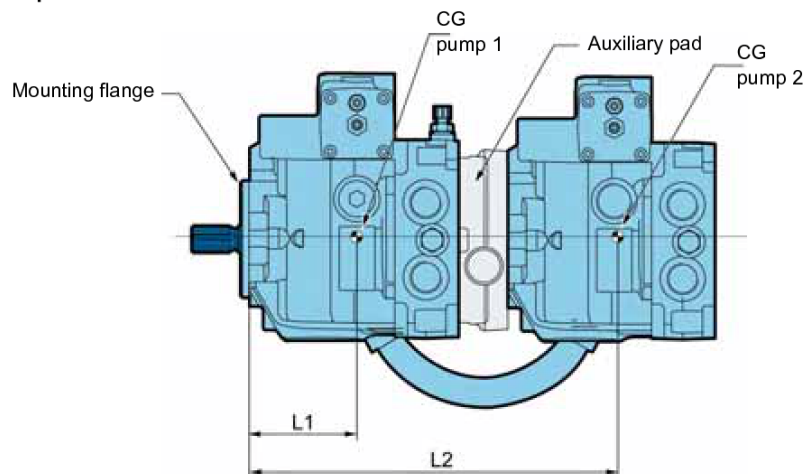

Estimating overhung load moments

W = Weight of pump (kg)
 L = Distance from mounting flange to pump center of gravity (CG)
 $M_R = G_R (W_1 L_1 + W_2 L_2 + \dots + W_n L_n)$
 $M_S = G_S (W_1 L_1 + W_2 L_2 + \dots + W_n L_n)$

Where:

M_R = Rated load moment (N.m)
 M_S = Shock load moment (N.m)
 G_R^* = Rated (vibratory) acceleration (G's) (m/sec²)
 G_S^* = Maximum shock acceleration (G's) (m/sec²)

*Calculations will be carried out by multiplying the gravity ($g = 9.81 \text{ m/sec}^2$) with a given factor. This factor depends on the application.

Allowable overhung load moment are shown in the above table. Exceeding these values requires additional pump support.



For an accurate calculation, consult your Poclain Hydraulics application engineer.

FEATURES

High pressure relief valve

The High pressure relief valves maintain circuit pressure in the proper range. The check valves allow charge flow to replenish the low pressure loop of the circuit. The high pressure relief valves ensure a high pressure protection of the high pressure loop of the circuit.

High pressure relief valves are available in a range of settings.

When high pressure relief valves are not desired, pumps is equipped with charge circuit check valves only.



High pressure relief valves are intended for transient overpressure protection and are not intended for continuous pressure control. Flow over relief valves for extended periods of time may result in severe heat build up. High flows over relief valves may result in pressure levels exceeding the nominal valve setting and potential damage to system components.



High pressure relief valve	Available setting bar [PSI]	
Without	-	00
	100 [1 450]	10
	150 [2 175]	15
With	200 [2 900]	20
	250 [3 625]	25
	300 [4 351]	30
	350 [5 076]	35

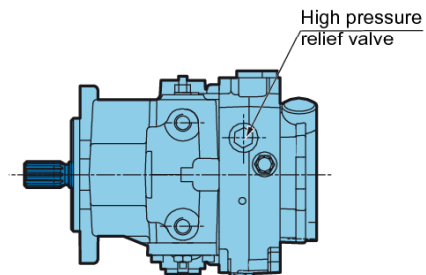
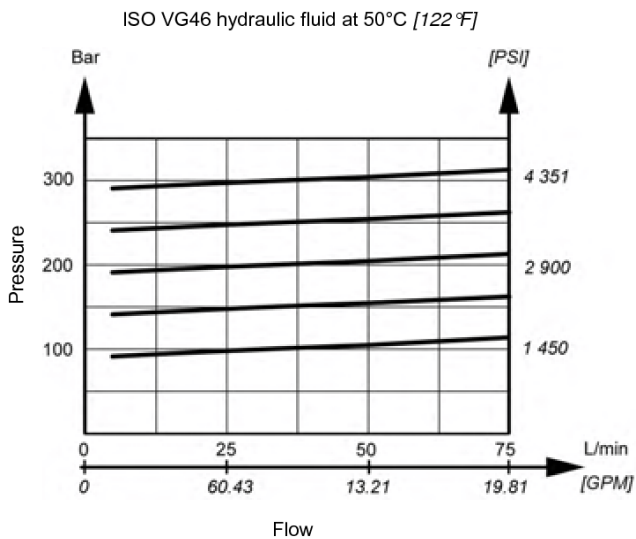
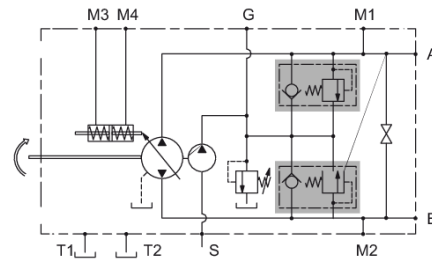

The high pressure relief valve setting is not the differential pressure between A and B ports (see page 13).

Charge relief valve

The charge pressure relief valve provides a relief outlet for charge circuit. This valve is used to set the charge pressure of the circuit. Flow through the valve is ported to case.

The nominal charge relief setting is referenced to case pressure.



Incorrect charge pressure settings may result in the inability to build required system pressure and/or inadequate loop flushing flows. Ensure correct charge pressure under all conditions of operation to maintain pump control performance.



Charge relief valve		Available setting bar [PSI]	
Without		-	00
With	For M and N controls	10 [145]	10
	For servo controls	20 [290]	20

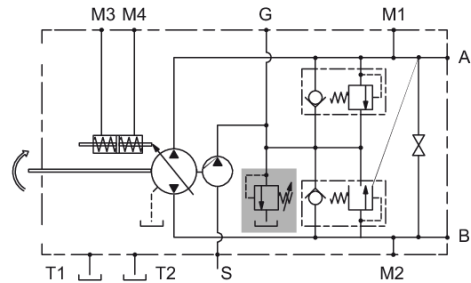

ISO VG46 hydraulic fluid at 50°C [122°F]

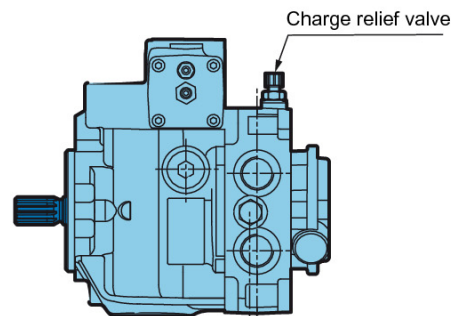
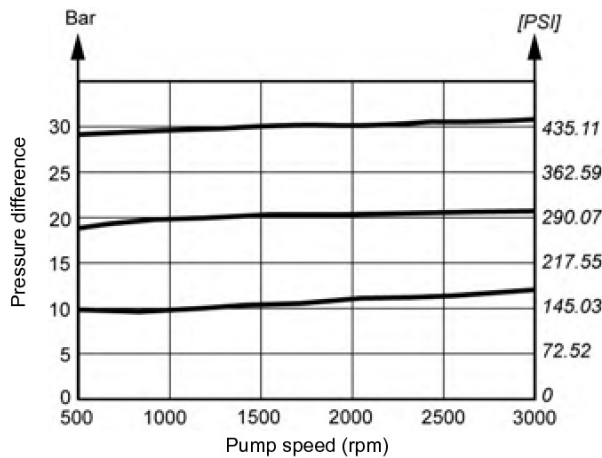

Charge pump

Charge flow is required on all PM10 pumps used in closed circuit installations. The charge pump provides flow to make up internal leakage, maintain a positive pressure in the main circuit, provide flow for cooling and filtration, replace any leakage losses from external valving or auxiliary systems, and to provide flow and pressure for the control system. Many factors influence the charge flow requirements. These factors include system pressure, pump speed, pump swashplate angle, type of fluid, temperature, size of heat exchanger, length and size of hydraulic lines, control response characteristics, auxiliary flow requirements, hydrostatic motor type, etc. Unusual application conditions may require a more detailed review of charge pump sizing. Charge pressure must be maintained at a specified level under all operating conditions to prevent damage to the transmission. Poclairn Hydraulics recommends testing under actual operating conditions to verify this.

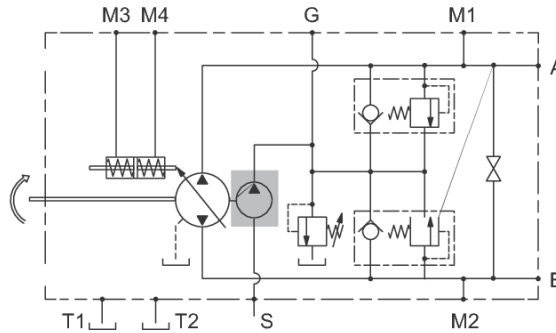

Charge pump sizing/selection

In most applications, a general guideline is that the charge pump displacement should be at least 20% of the main pump displacement.



Charge pump	Displacement cm ³ /rev [in ³ /rev]	Rated speed (rpm)	
Without	-	-	00
For auxiliary mounting pad F and G	4,9 [0.30]	3900	05
With			
For auxiliary mounting pad A	7,0 [0.43]	3900	07
For tandem pump with auxiliary mounting pad A	9,0 [0.55]	3900	08

Contact your Poclairn Hydraulics application engineer for more information.

Displacement limiters

PM10 are designed with mechanical displacement (stroke) limiters. You can limit maximum displacement of the pump to a certain percent of its maximum displacement to near zero in both direction.

The displacement limiters are located on the both sides of the servo piston and are adjustable by screw.



Take care in adjusting displacement limiters to avoid an undesirable condition of output flow or speed. Retorque the sealing lock nut after every adjustment to prevent an unexpected change in output conditions and to prevent external leakage during pump operation.

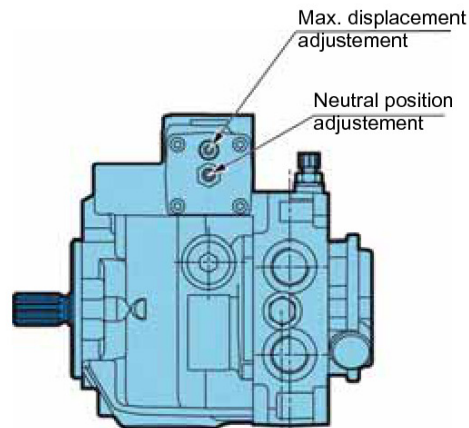

By-pass

PM10 features a by-pass function. By-passing Port A and Port B is achieved by unscrewing a screw located on the cover. The by-pass connect the ports A-B and must be use only in emergency case and only for short movement.

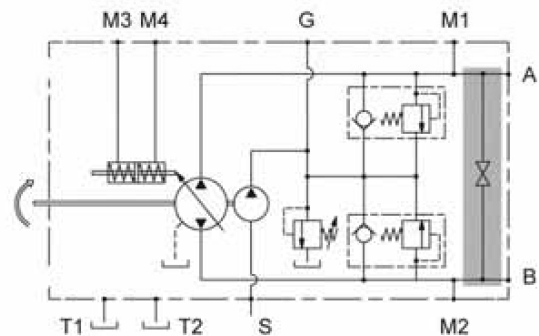
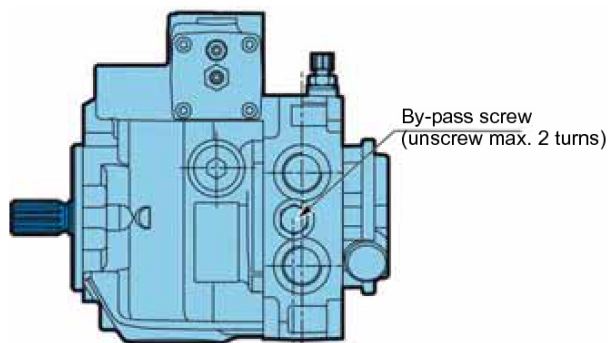

To avoid leakage, do NOT exceed two turns of the screw.



By-pass valve is intended for moving a machine for very short distances at very slow speeds. It is NOT intended as tow valve.

Mounting flange and shafts

SAE A - Splined shaft

P	M	1	0	1	2	3	4	5	6	7	8	9	10	11	12
				A											

S1 9 teeth; Max torque: 80 N.m [708 in.lbf]

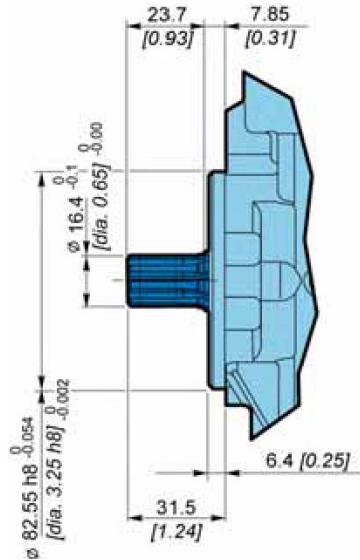

Splined ANSI B92.1a-1976
Pitch 16/32" DP
Pressure angle 30°
Tolerance class: 5

S2 11 teeth; Max torque: 140 N.m [1 239 in.lbf]

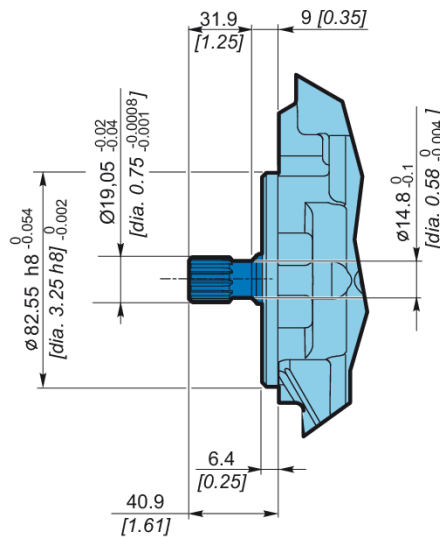

Splined ANSI B92.1a-1976
Pitch 16/32" DP
Pressure angle 30°
Tolerance class: 5

SAE B - Splined shaft



S2 11 teeth; Max torque: 140 N.m [1 239 in.lbf]

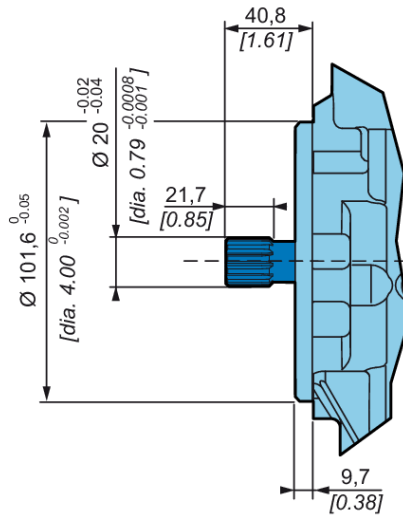

Splined ANSI B92.1a-1976
Pitch 16/32" DP
Pressure angle 30°
Tolerance class: 5

S3 13 teeth; Max torque: 220 N.m [1 947 in.lbf]

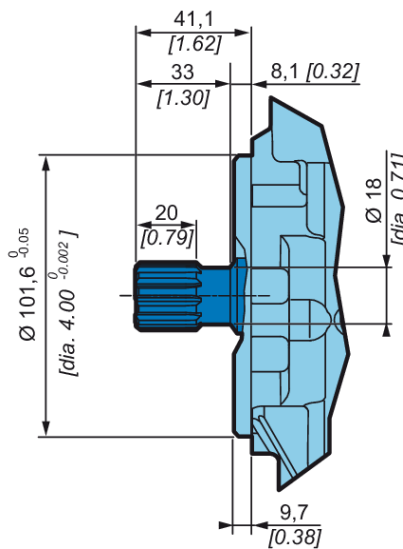

Splined ANSI B92.1a-1976
Pitch 16/32" DP
Pressure angle 30°
Tolerance class: 5

Auxiliary mounting pad

SAE A flange

Max. Torque: 80 N.m [708 in.lbf]



00 Without charge pump

07 With charge pump: 7,0 cm³/rev [0.43 in³/rev]

08 With charge pump: 9,0 cm³/rev [0.55 in³/rev]

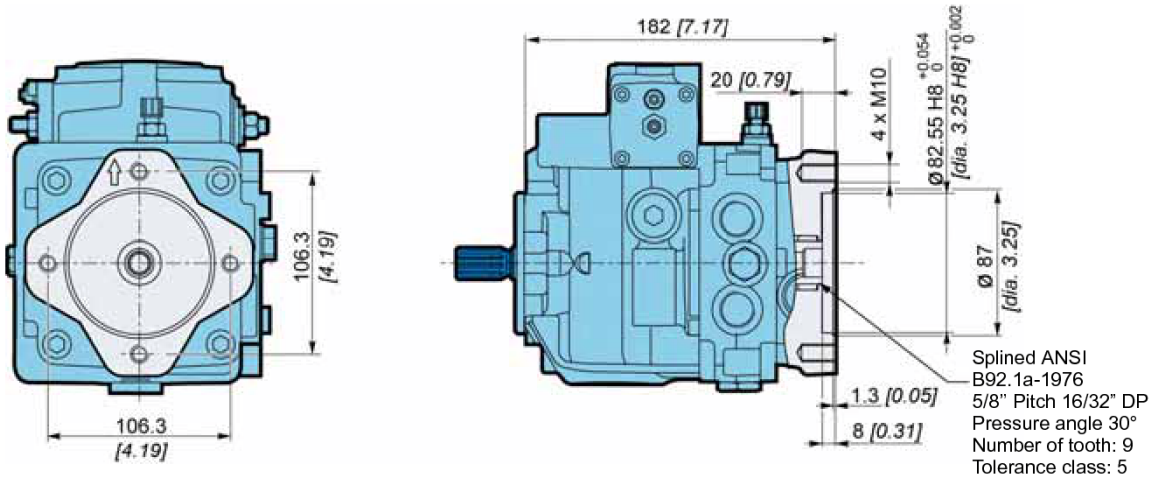

Do not rotate the auxiliary mounting pad cover.

German group 1 flange

Max. torque: 48 N.m [425 in.lbf]



00 Without charge pump

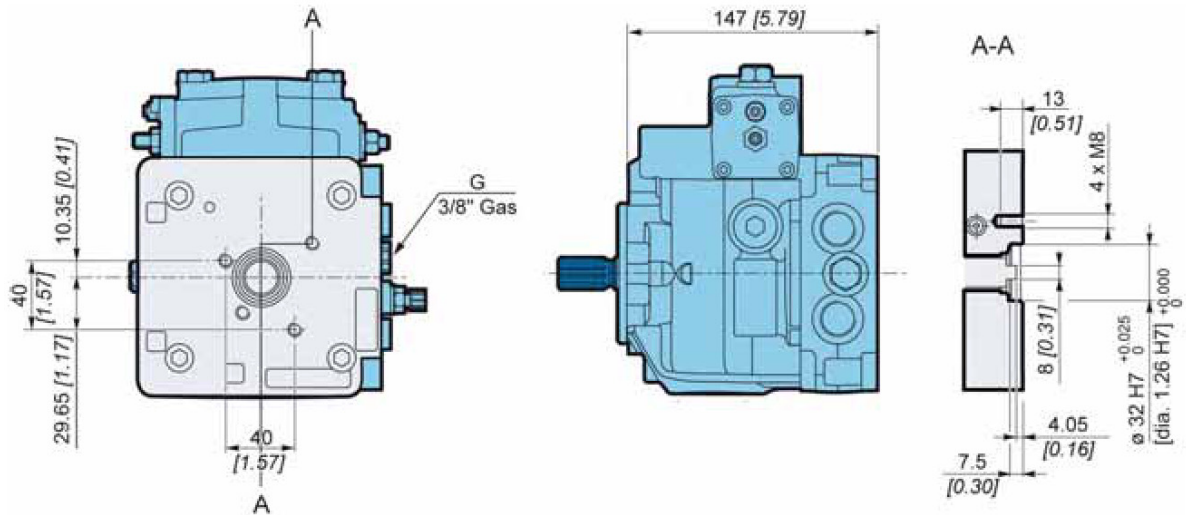

05 With charge pump: 4,9 cm³/rev [0.30 in³/rev]

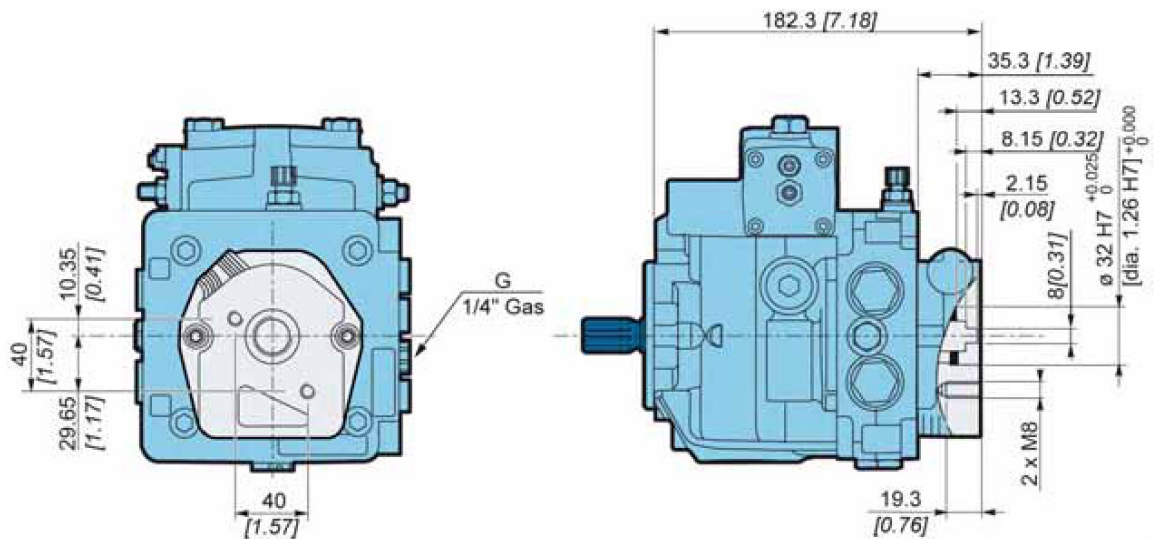

Do not rotate the auxiliary mounting pad cover.

German group 2 flange

Max. torque: 70 N.m [620 in.lbf]



00 Without charge pump

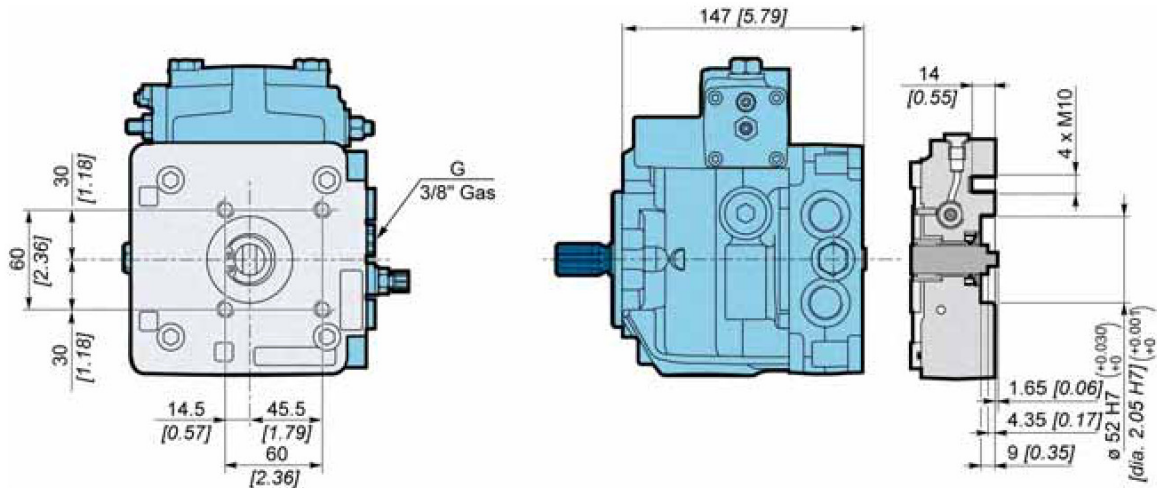

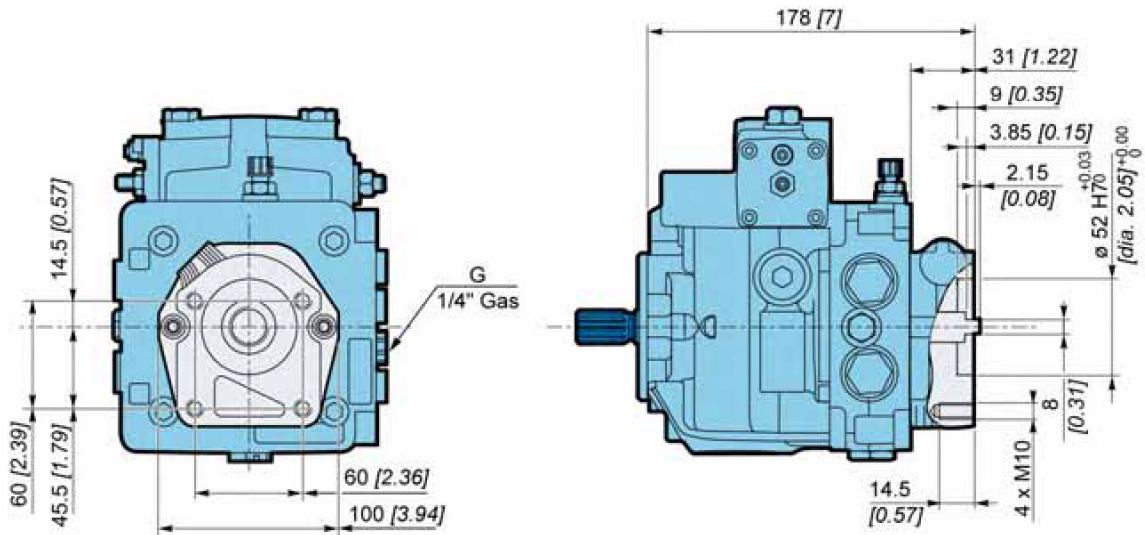

05 With charge pump: 4,9 cm³/rev [0.30 in³/rev]



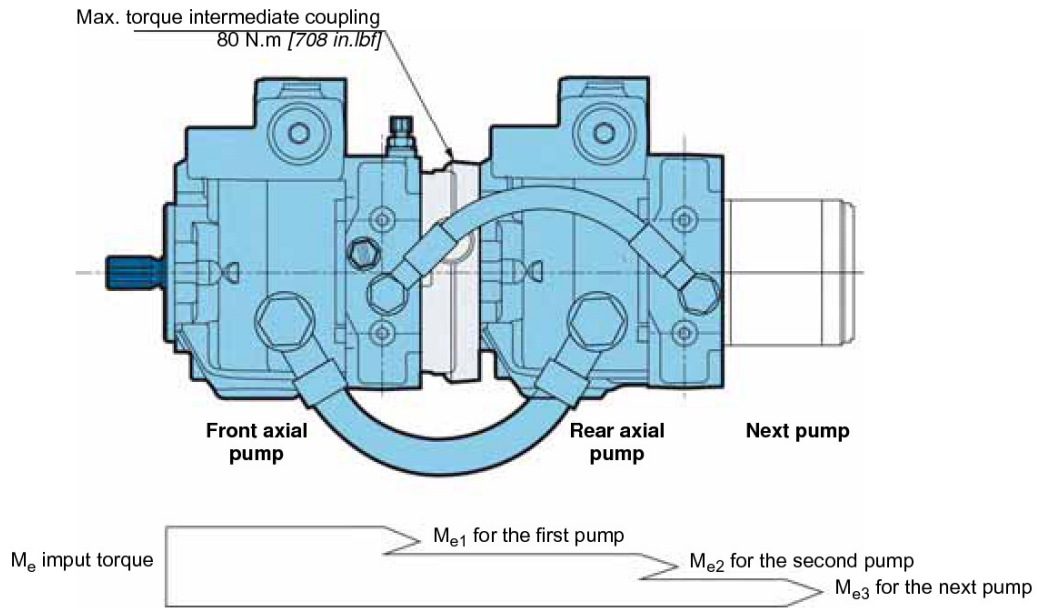

Do not rotate the auxiliary mounting pad cover.

Tandem pumps

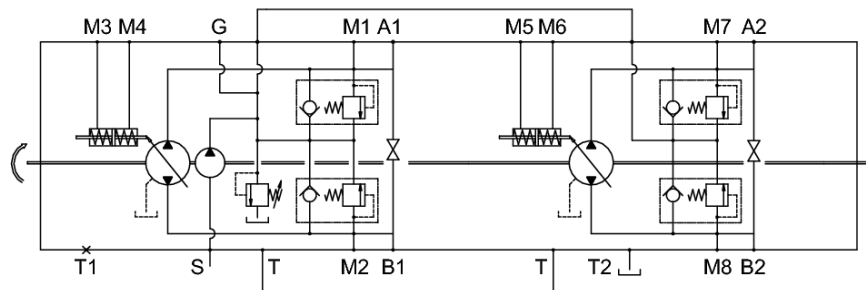

 **Torque required by gear pumps is additive. Ensure requirements don't exceed shaft torque ratings.**



 **Ports T and G of the first pump must be connected with ports T and G of the second pump.**

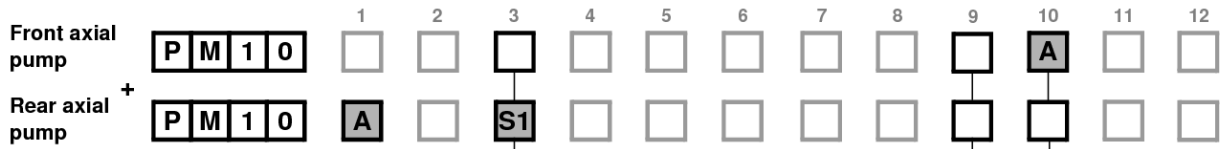

Number of charge pump in the tandem	Axial pump	Mounting flange and shaft	Charge pump	Auxiliary mounting flange		
1 charge pump*	Front	SAE A; 11 teeth	S2	07		
		SAE B; 11 teeth	S2	08		
		SAE B; 13 teeth	S3	08		
	Rear	SAE A; 9 teeth	S1	Without	00	
					Without auxiliary mounting pad	S
					German group 2	G
				SAE A	A	
2 charge pumps	Front	SAE A; 11 teeth	S2	07		
		SAE B; 11 teeth	S2	08		
		SAE B; 13 teeth	S3	08		
	Rear	SAE A; 9 teeth	S1	With	05	
					Without auxiliary mounting pad	S
					German group 2	G
				07	A	
				08	A	



* The charge pump in the front axial pump is mandatory.

Gear pumps

1 2 3 4 5 6 7 8 9 10 11 12

	Displacement cm ³ /rev [cu.in/rev]	Pressure			Dimension			Mass kg [lb]	Efficiency %
		Continuous max. pressure bar [PSI]	Max. intermittent pressure bar [PSI]	Max. peak pressure bar [PSI]	A mm [in]	B mm [in]	C mm [in]		
F 	01	1,6 [0.10]	210 [3 045]	240 [3 480]	260 [3 770]	76,4 [3.01]			95*
	02	2,0 [0.12]	210 [3 045]	240 [3 480]	260 [3 770]	77,9 [3.07]			
	03	3,2 [0.19]	200 [2 900]	240 [3 480]	250 [3 625]	82,6 [3.25]	67 [2.64]	70 [2.76]	
	04	4,2 [0.26]	180 [2 610]	210 [3 045]	230 [3 335]	86,5 [3.41]			
	05	5,0 [0.30]	180 [2 610]	210 [3 045]	230 [3 335]	89,6 [3.53]			
	06	6,3 [0.38]	170 [2 465]	190 [2 755]	210 [3 045]	94,7 [3.73]			
G 	04	4,5 [0.27]	250 [3 625]	270 [3 915]	290 [4 205]	90,3 [3.55]			95*
	06	6,0 [0.37]	250 [3 625]	270 [3 915]	290 [4 205]	93,6 [3.68]			
	08	8,5 [0.52]	250 [3 625]	270 [3 915]	290 [4 205]	97,8 [3.85]	88 [3.46]	100 [3.94]	
	11	11,0 [0.67]	250 [3 625]	270 [3 915]	290 [4 205]	101,9 [4.01]			
	14	14,5 [0.88]	250 [3 625]	270 [3 915]	290 [4 205]	106,9 [4.21]			
	17	17,0 [1.04]	230 [3 335]	240 [3 480]	250 [3 625]	111,1 [4.37]			
A 	04	4 [0.24]	250 [3 625]	270 [3 915]	290 [4 205]	93,0 [3.66]			95*
	06	6,0 [0.37]	250 [3 625]	270 [3 915]	290 [4 205]	96,3 [3.68]			
	08	8,5 [0.52]	250 [3 625]	270 [3 915]	290 [4 205]	100,5 [3.96]			
	11	11,0 [0.67]	250 [3 625]	270 [3 915]	290 [4 205]	104,6 [4.12]	130,4 [5.13]	95 [3.74]	
	14	14 [0.85]	250 [3 625]	270 [3 915]	290 [4 205]	109,6 [4.21]			
	17	16,5 [1.01]	230 [3 335]	240 [3 480]	250 [3 625]	113,8 [4.37]			
	20	19,5 [1.19]	210 [3 045]	220 [3 190]	230 [3 335]	118,8 [4.68]			

Gear pumps are always delivered flanged on the axial pump. They can not be sold alone.

* Value collected during the testing at 1500 rpm.

CONTROLS

Direct mechanical controls

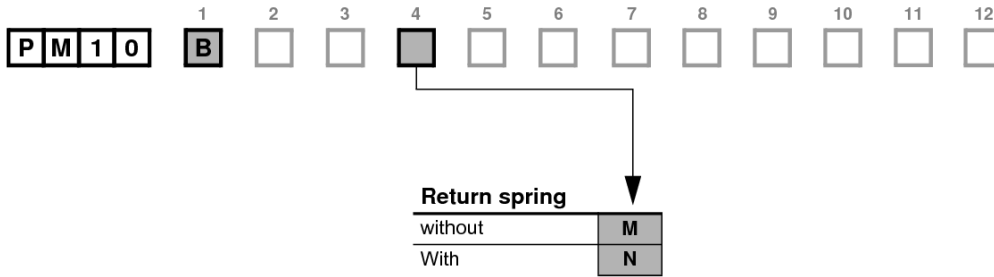

The variation in pump displacement is obtained by rotating the lever shaft in a clockwise or counter-clockwise direction.

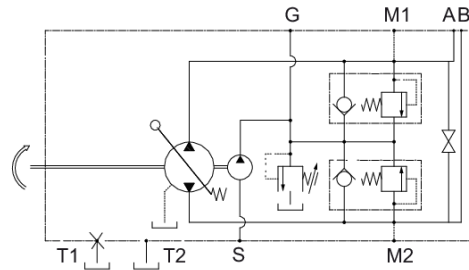

Flow rate determination

Rotation	Pressure	Output	Input
Clockwise (R)	X	A	B
	Y	B	A
Counter clockwise (L)	X	B	A
	Y	A	B

Pump Max. displacement cm ³ /rev [in ³ /rev.]	Angle to reach max. displacement
7,08 [0.43]	11°
9,08 [0.55]	14°
11,83 [0.72]	18°
14,32 [0.87]	17°
17,85 [1.09]	18°
20,40 [1.24]	19°

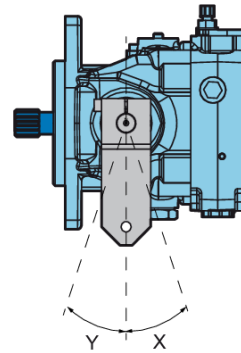

The spring return feature in the control unit is not a safety device.

Hydraulic servo control



The variation in pump displacement is obtained by adjusting the pressure on the M3 and M4 servo control connections by means of a hydraulic proportional joystick (containing pressure reduction valves).

The joystick supply can be obtained by taking pressure from the auxiliary pump (G connection).

The servo control timing can be adjusted by inserting a restrictor on the joystick supply line (from 0.5 to 1 mm [from 0.02 to 0.04 in]) or between the joystick and servo piston of the pump.

The servo control operation curve in both control directions goes from 4,5±0,5 to 14,5±0,5 bar [from 87±7.3 to 217±7.3 PSI]. The adjustment curve of the hydraulic control system has to be wider (from 3,5 to 16 bar [from 50.8 to 232 PSI]).

Flow rate determination

Rotation	Pressure	Output	Input
Clockwise (R)	M3	B	A
	M4	A	B
Counter clockwise (L)	M3	A	B
	M4	B	A

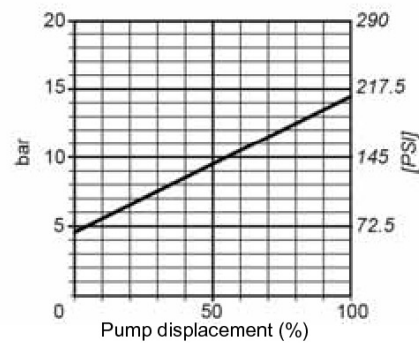
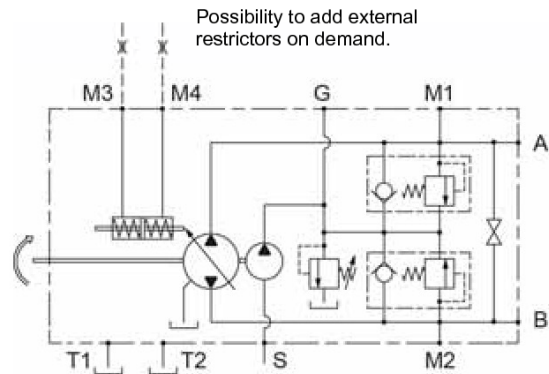

The back pressure of the return line of the joystick and the drive line of the pump have an influence on these values.



The spring return feature in the control unit is not a safety device.

Dimensions

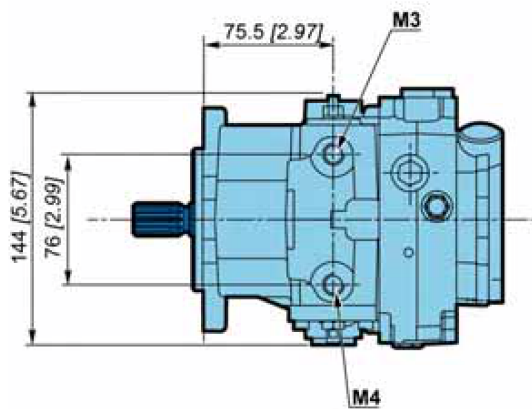
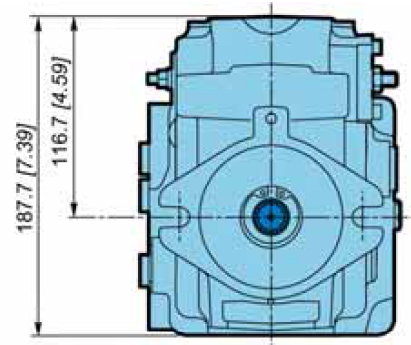
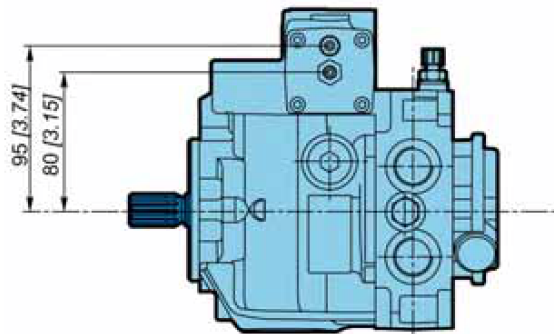

See page 7 for other dimensions and port characteristics.

Mechanical servo control with feed back



The variation in pump displacement is obtained by rotating the drive lever situated on the servo control. An internal channel, linked to the charge pump, feeds a hydraulic servo valve which supplies oil into the cylinder which is in turn linked to the pump swashplate. The maximum rotation of the lever, with respect to 0 is 30° for both rotation directions; thus permitting the optimum control of the displacement.

At every lever angle there is a corresponding pump displacement. On the 2 lines, between the pilot control A and the servo piston, 2 restrictors R1 and R2 are mounted which regulates the servo control shifting speed, thus avoiding sudden accelerations and stoppages.

The effort of moving the lever is independent of the pressure and rpm.

Flow rate determination

Rotation	Control	Output	Input
Clockwise (R)	X	A	B
	Y	B	A
Counter clockwise (L)	X	B	A
	Y	A	B

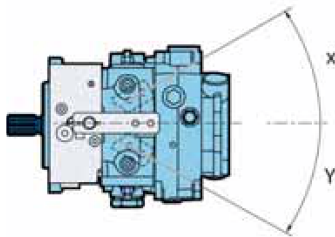
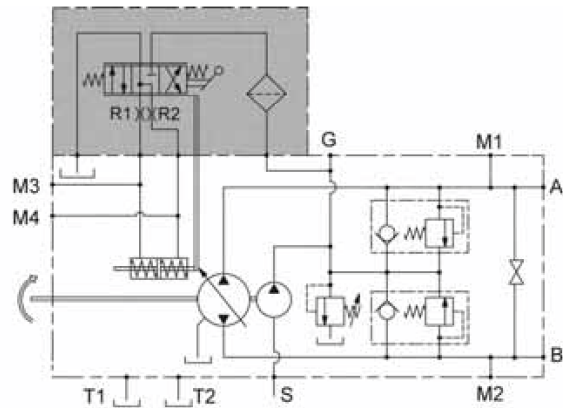

To prevent damage to the control A a positive mechanical stop must be provided for the control A linkage.

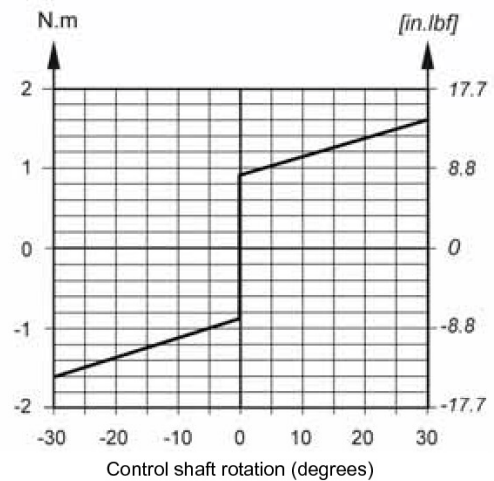

The spring return feature in the control unit is not a safety device.

Dimensions

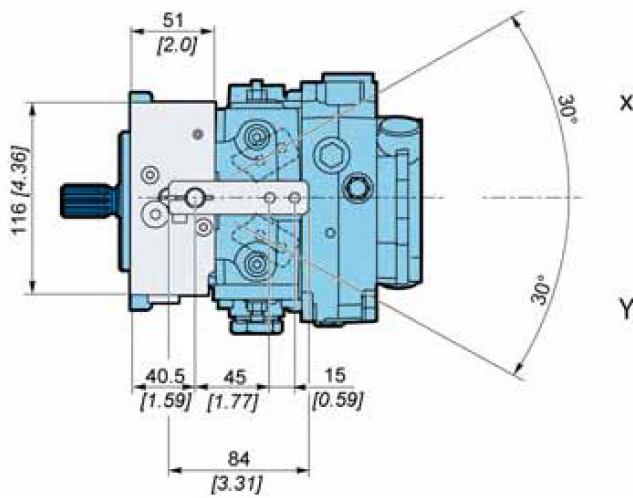
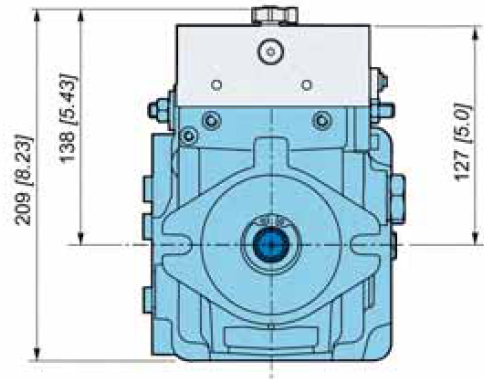
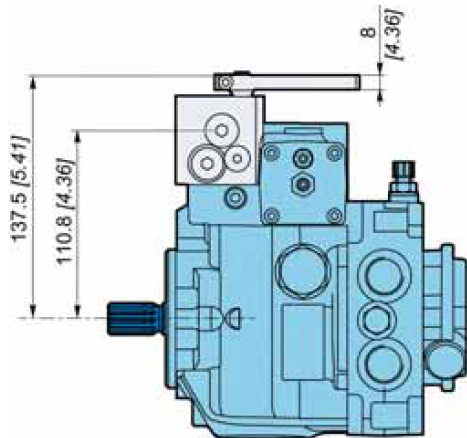

See page 7 for other dimensions and port characteristics.

Electrical on-off servo control

Control with return spring



The reaching of the maximum displacement in a time defined by the R1 and R2 restrictors which are positioned between the electrovalve and the servo-control is obtained by the continuous operation of an ON-OFF electro-valve with an open-circuit CETOP 2 connection.

If the electrovalve motion is stopped, the pump goes back to "0" position thanks to the servo control springs.

The pump can be supplied either without electrovalve (B00) or with electro-valve (B12, B24).

Supply voltage	
without	B00
12V	B12
24V	B24

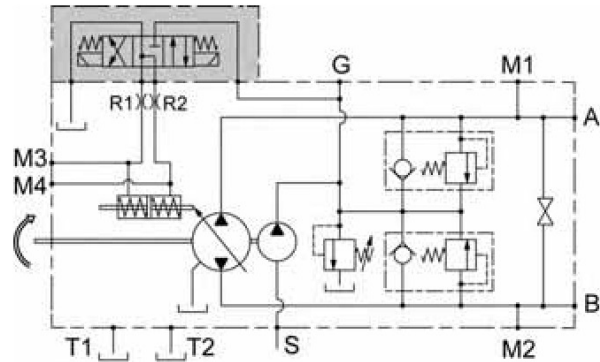

Control without return spring



The variation in pump displacement is obtained by the energizing of an ON-OFF electro-valve with a closed center CETOP 2 connection.

The displacement reached is in relation to the starting time of the electro-valve and to the diameter of the R1 and R2 restrictors which are placed between the electrovalve and the servo-control.

The pump can be supplied either without electrovalve (C00) or with electrovalve (C12, C24).

The servo control is without springs and the setting of the pump at a certain displacement is guaranteed by the closed center of the electrovalve.

Supply voltage	
without	C00
12V	C12
24V	C24

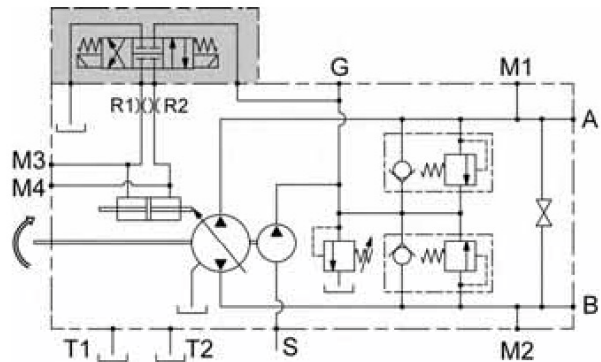

Flow rate determination

Rotation	Control	Pressure	Output	Input
Clockwise (R)	EV1	A	A	B
	EV2	B	B	A
Counter clockwise (L)	EV1	A	B	A
	EV2	B	A	B



The spring return feature in the control unit is not a safety device.

Dimensions

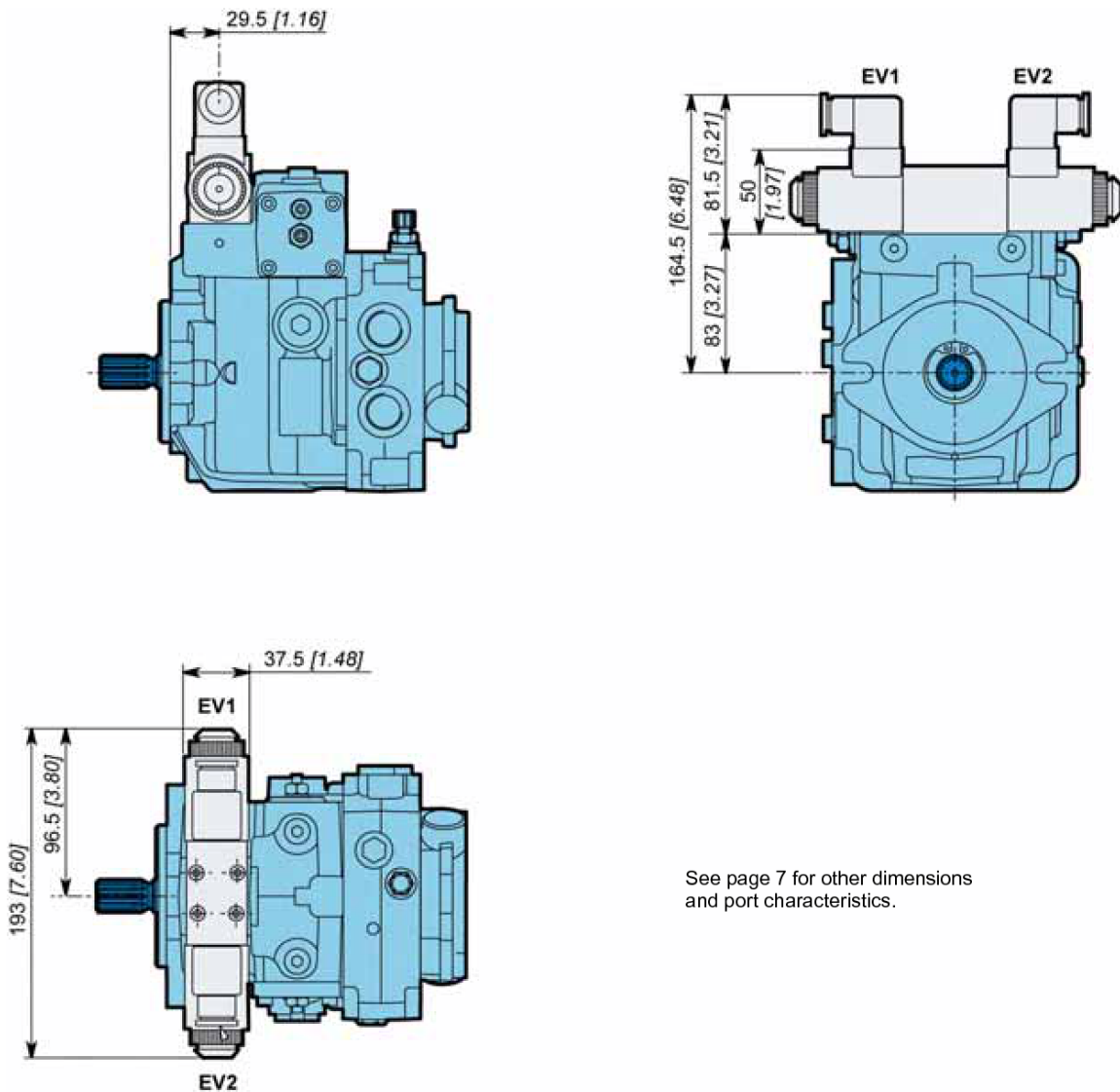

See page 7 for other dimensions and port characteristics.

Type of connector: DIN 43650

Electrico-proportional servo control



By means of a potentiometer and a control card, a voltage signal is applied to the proportional electro-valve coils which adjust the pressure of the servo control connected to the pump swashplate.

At every position of the potentiometer lever, there is a corresponding displacement.

The flow rate direction depends on which coil is excited.

The adjustment speed can be controlled by ramps installed on the card and by restrictors R1 and R2 positioned between the electro-valve and the servo control.

Supply voltage	
12V	P12
24V	P24

Flow rate determination

Rotation	Control	Output	Input
Clockwise (R)	EP1	B	A
	EP2	A	B
Counter clockwise (L)	EP1	A	B
	EP2	B	A

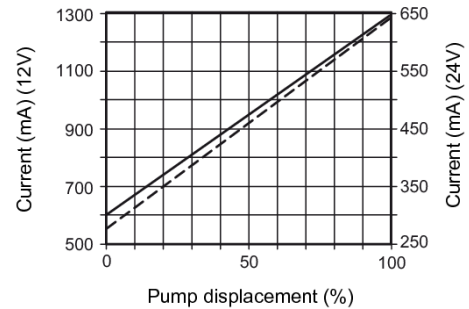
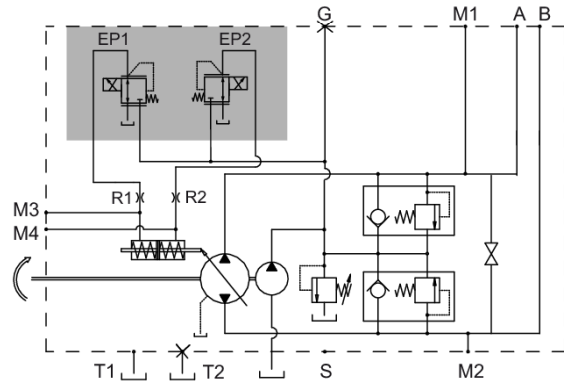

From 0 to max. displacement: ———
 From max. displacement to 0: - - - -



The spring return feature in the control unit is not a safety device.

Dimensions

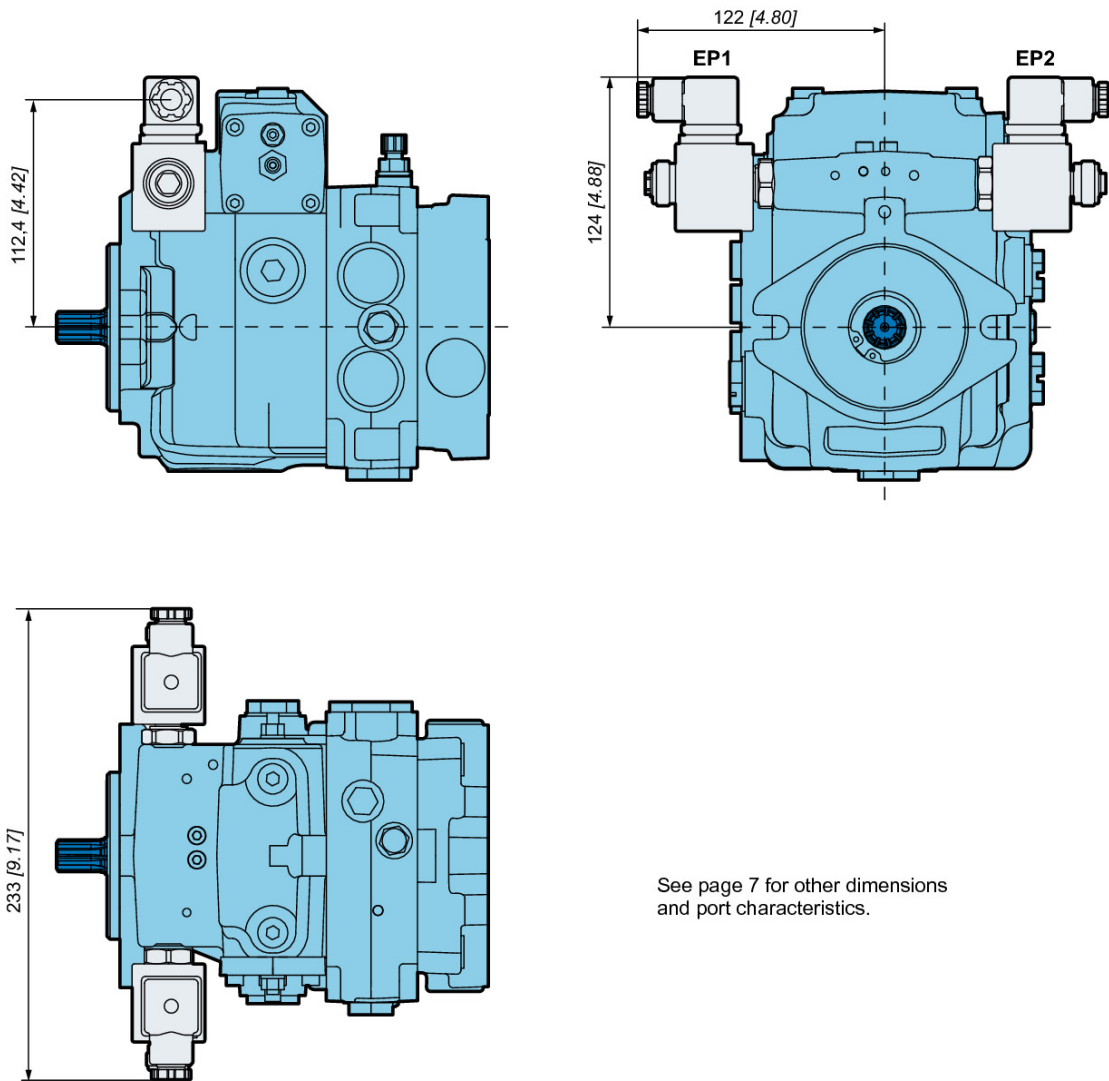

See page 7 for other dimensions and port characteristics.

Type of connector: DIN 43650

Hydraulic automotive control



In relation to the input rotation rate, the pump swashplate positioning cylinder is actuated by the pressure of the adjustment valve and a 4/3 electro-hydraulic valve, progressively positioning the swashplate. This provides a continuously variable pump displacement. The direction of the supplied flow is determined by which of the two solenoids is energized.

The pilot pressure increases proportionally to the rotation plate. A pump displacement increase corresponds to the higher pilot pressure.

In case the prime mover is overloaded, the rotation rate decreases and the pilot pressure is reduced causing a pump displacement reduction with a corresponding drop in absorbed power.

An "Inching" lever (option IC) is available to reduce the pilot pressure independently of the pump rotation speed.

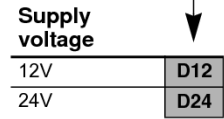

Flow rate determination

Rotation	Control	Output	Input
Clockwise (R)	EV1	B	A
	EV2	A	B
Counter clockwise (L)	EV1	A	B
	EV2	B	A

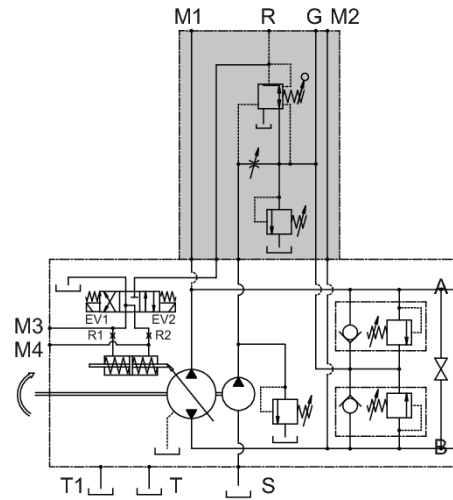

Dimensions with option IC

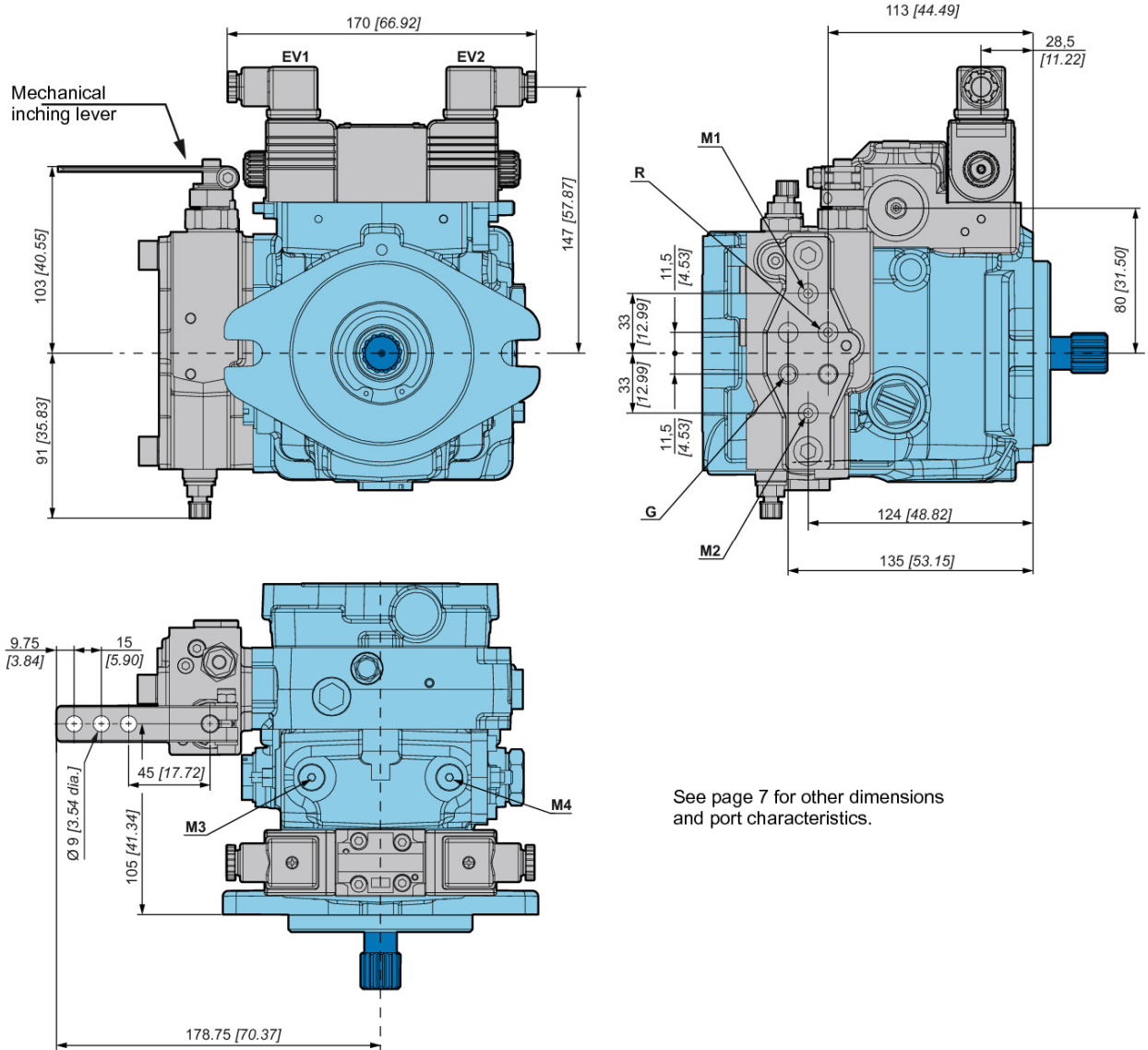

See page 7 for other dimensions and port characteristics.

Type of connector: DIN 43650

OPTIONS

Roller bearing

P	M	1	0	1	2	3	4	5	6	7	8	9	10	11	12
				<input type="checkbox"/>	<input type="checkbox"/>	<input type="checkbox"/>	<input type="checkbox"/>	<input type="checkbox"/>	<input type="checkbox"/>	<input type="checkbox"/>	<input type="checkbox"/>	<input type="checkbox"/>	<input type="checkbox"/>	<input type="checkbox"/>	<input checked="" type="checkbox"/>

It is an optional high capacity bearing.

Depending on the characteristics of shaft load, the duty cycle of the application and the expected life time of your application, Roller bearing might be needed.

Consult your Poclairn Hydraulics Application Engineer.

Fluorinated elastomer seals

P	M	1	0	1	2	3	4	5	6	7	8	9	10	11	12
				<input type="checkbox"/>	<input type="checkbox"/>	<input type="checkbox"/>	<input type="checkbox"/>	<input type="checkbox"/>	<input type="checkbox"/>	<input type="checkbox"/>	<input type="checkbox"/>	<input type="checkbox"/>	<input type="checkbox"/>	<input type="checkbox"/>	<input checked="" type="checkbox"/>

Standard NBR sealing are designed to resist to temperature up to 90°C [194 °F] and to HV type oils.

If your application is outside these limits, Fluorinated elastomer seals might be recommended.

Consult your Poclairn Hydraulics Application Engineer.

UNF threads ports

P	M	1	0	1	2	3	4	5	6	7	8	9	10	11	12
				<input type="checkbox"/>	<input type="checkbox"/>	<input type="checkbox"/>	<input type="checkbox"/>	<input type="checkbox"/>	<input type="checkbox"/>	<input type="checkbox"/>	<input type="checkbox"/>	<input type="checkbox"/>	<input type="checkbox"/>	<input type="checkbox"/>	<input checked="" type="checkbox"/>

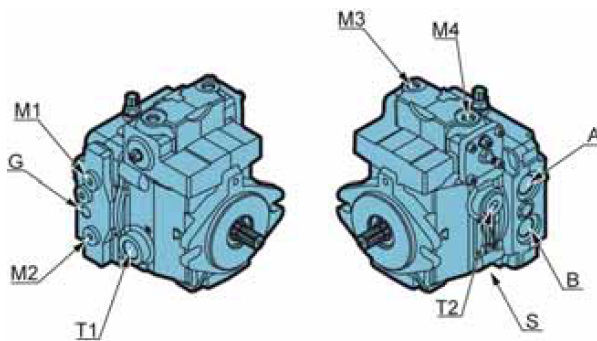

Port	Function	ISO 11926-1 (option FU)
A-B	Services	3/4-16 UNF-2B
G	Auxiliary	7/16-20 UNF-2B
M1/M2	Gauge	7/16-20 UNF-2B
M3/M4	Servo control pilot	7/16-20 UNF-2B
S	Suction	1-1/16-12 UNF-2B
T1/T2	Drain	7/8-14 UNF-2B

Filter on pressure line

The PM10 pumps can have a pressure filter without clogging indicator (F0) or with clogging indicator (F2). The flow thru the filter is only the flow that entry in the close loop. The filter fitness is of 10 micron.

Maximum pressure difference between filter cartridge input and output is 2 bar [29 PSI]. When reaching 2 bar [29 PSI], the cartridge has to be changed.

Max. working pressure: 30 bar [435 PSI].

Tightening torque: 35 Nm [309 in.lbf].

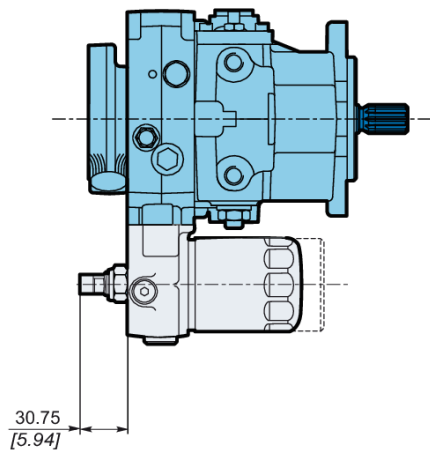
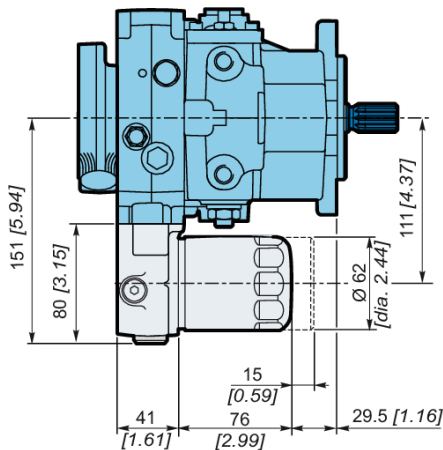
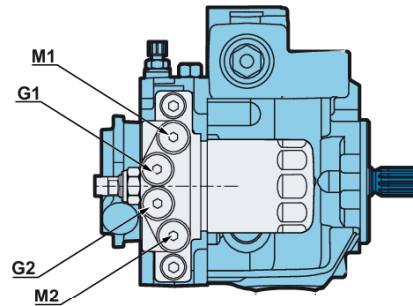
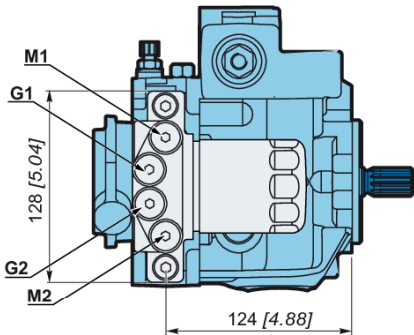
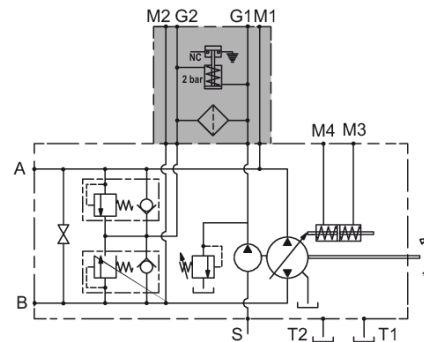
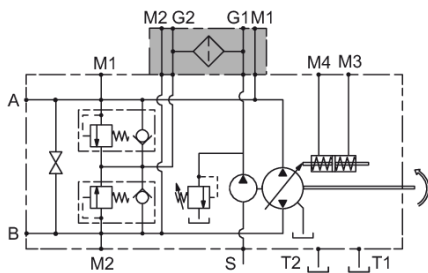
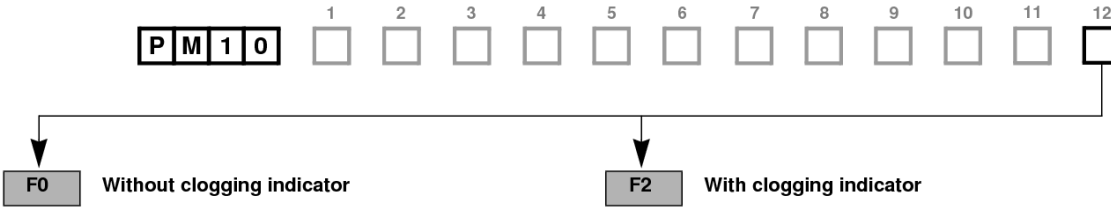

Neutral position switch



For the control A it is possible to obtain a micro switch to avoid the start of the engine if the lever of the control is not in center (zero position).

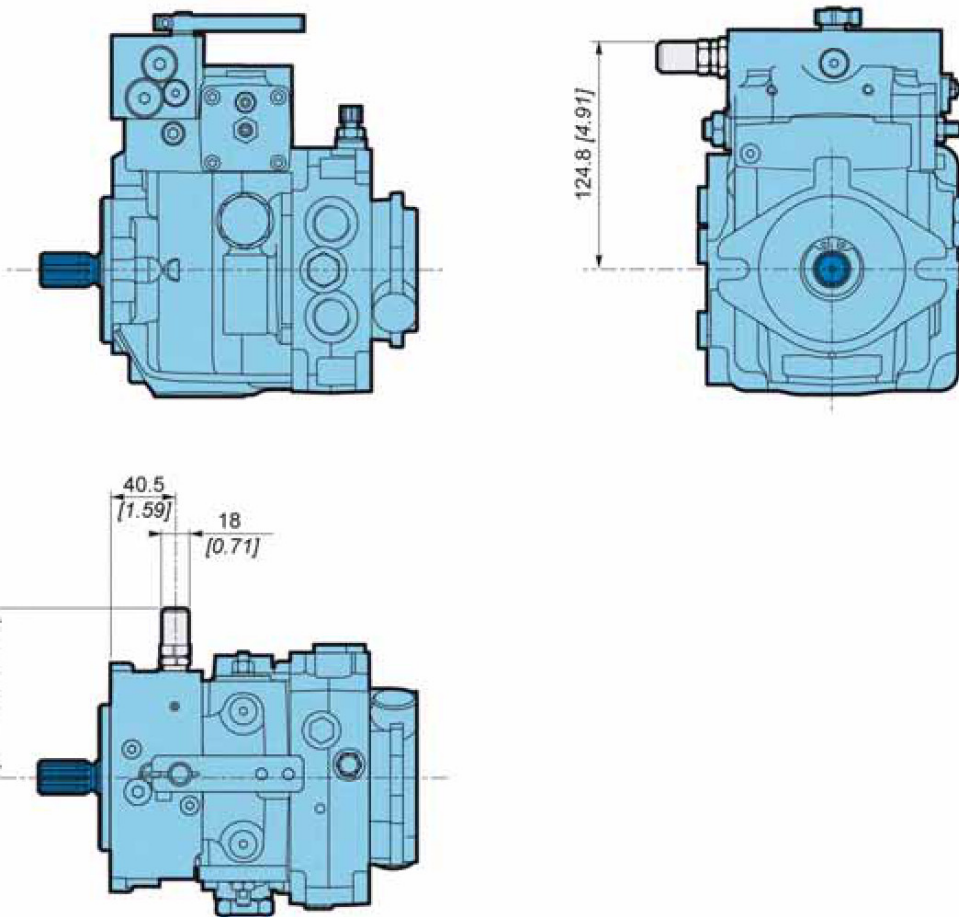
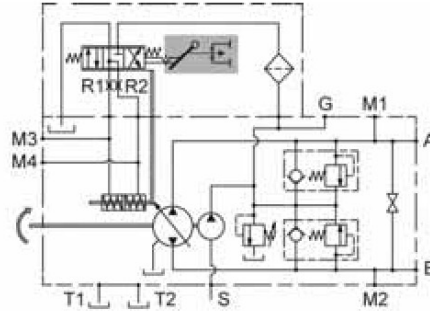

Type of connector: Deutsch DT04-2P

Safety valve



The pump PM10 can be provided with a safety valve VPU. Without current, the VPU disconnect the servo control from the charge pressure.

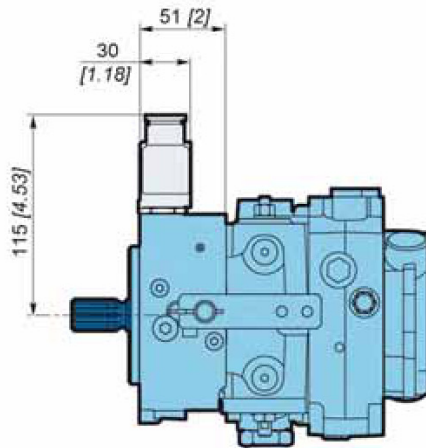
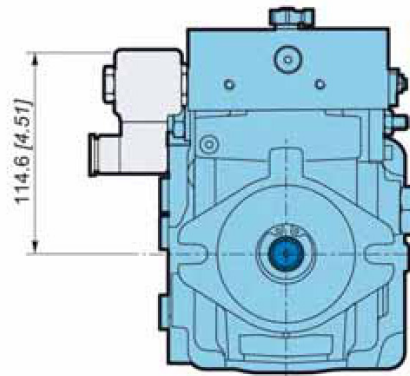
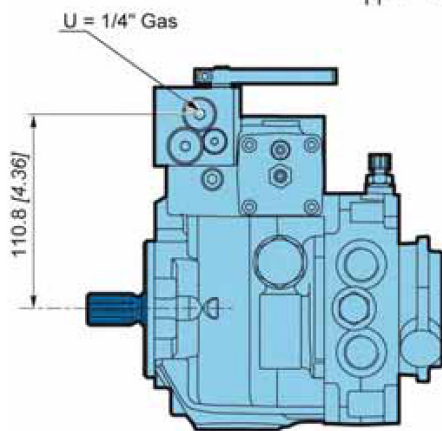
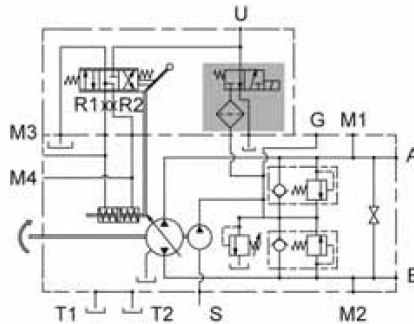

Type of connector: Deutsch DT04-2P

	1	2	3	4	5	6	7	8	9	10	11	12
P				S								VPU

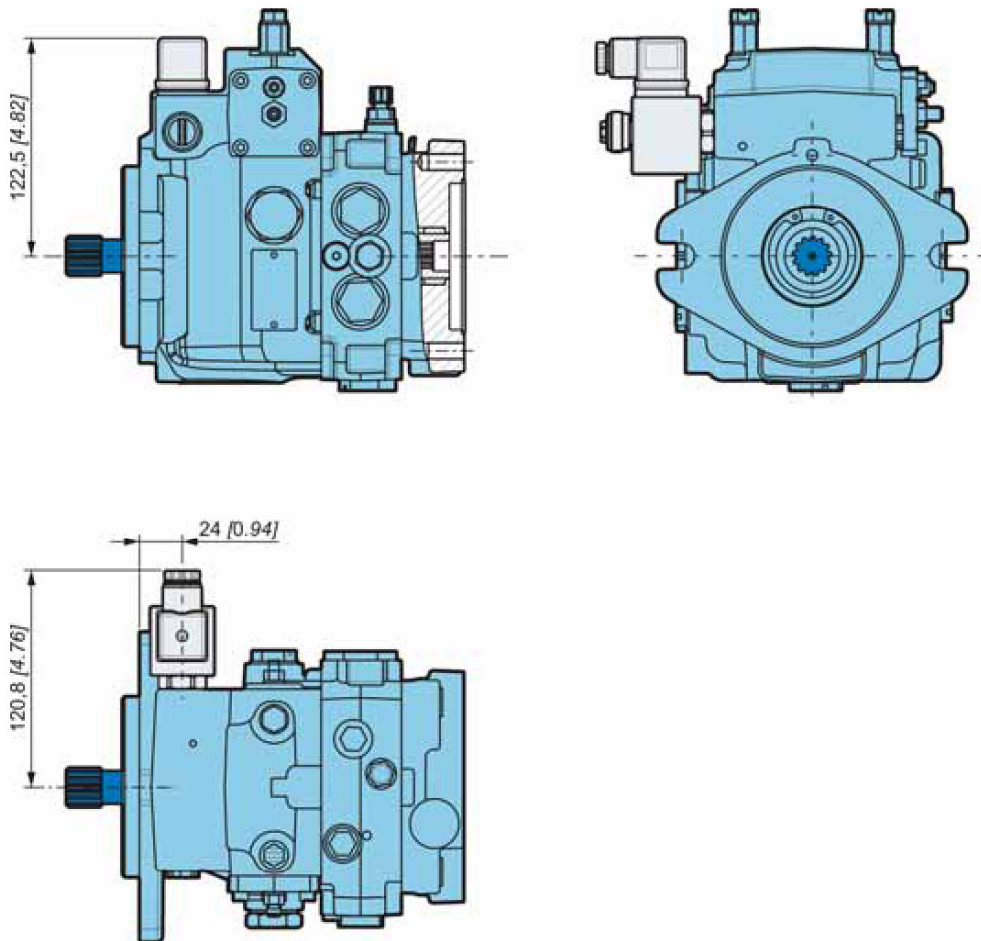
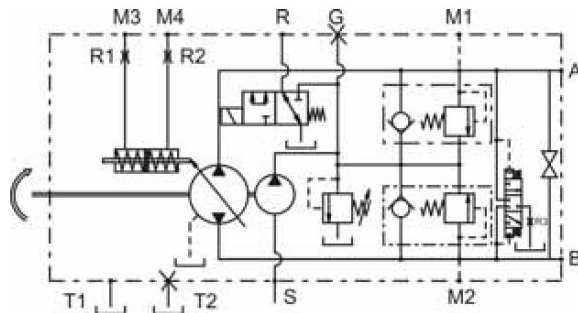

Flushing valve

P	M	1	0	1	2	3	4	5	6	7	8	9	10	11	12
				<input type="checkbox"/>	<input type="checkbox"/>	<input type="checkbox"/>	<input type="checkbox"/>	<input type="checkbox"/>	<input type="checkbox"/>	<input type="checkbox"/>	<input type="checkbox"/>	<input type="checkbox"/>	<input type="checkbox"/>	<input type="checkbox"/>	<input checked="" type="checkbox"/> VS

Inside the pump cover, a flushing valve can be fitted with discharge inside the pump casing by means of a calibrated hole. The flushing valve is useful in case the temperature of the oil in the closed circuit is too high.

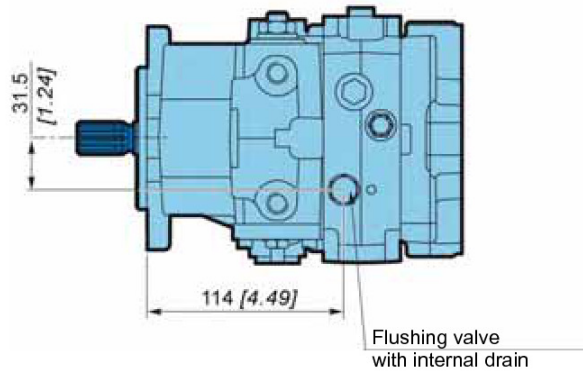
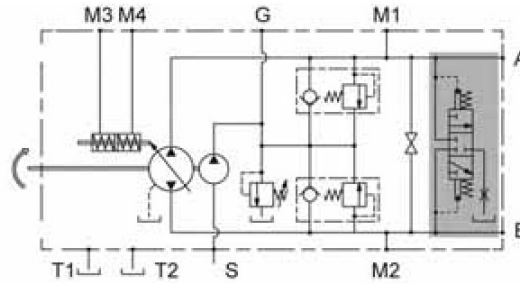

Mechanical inching

P	M	1	0	1	2	3	4	5	6	7	8	9	10	11	12
				<input type="checkbox"/>	<input type="checkbox"/>	<input type="checkbox"/>	or <input checked="" type="checkbox"/> D12 <input checked="" type="checkbox"/> D24	<input type="checkbox"/>	<input type="checkbox"/>	<input type="checkbox"/>	<input type="checkbox"/>	<input type="checkbox"/>	<input type="checkbox"/>	<input type="checkbox"/>	<input checked="" type="checkbox"/> IC

For hydraulic automotive control D. An "Inching" lever is available to reduce the pilot pressure independently of the pump rotation speed. See Hydraulic automotive control (D) page 39.

Finishing coat

P	M	1	0	1	2	3	4	5	6	7	8	9	10	11	12
				<input type="checkbox"/>	<input type="checkbox"/>	<input type="checkbox"/>	<input type="checkbox"/>	<input type="checkbox"/>	<input type="checkbox"/>	<input type="checkbox"/>	<input type="checkbox"/>	<input type="checkbox"/>	<input type="checkbox"/>	<input type="checkbox"/>	<input checked="" type="checkbox"/> PA

The pumps can be delivered with finishing coat when requested. Standard paint is RAL 9005 (black color).



Consult your Poclain Hydraulics application engineer for other colors of topcoat.