



PL6H PUMPS



PL6H14 – 320. HYDRAULIC PUMPS. CHARACTERISTICS

B						T			C			F			S				
1	2	3	4	5	6	1	2	3	1	2	3	1	2	3	1	2	3	4	5
P	L		H			F	O					4	7		0	0	0	0	0

	Displacement cm ³ /tr [cu.in./rev.]	Max. speed tr/min [RPM]		Flow(*) l/min [GPM]		Max. pressure bar [PSI]		Max. power (*) kW [HP]	
		Cont.	int.	Cont.	int.	Cont.	int.	Cont.	int.
2H14	2 x 17.5 [2 x 1.07]	2 700	3 100	2 x 47 [2 x 12.42]	2 x 54 [2 x 14.27]	350 [5 076]	450 [6 527]	55 [74]	81 [109]
	2 x 20 [2 x 1.22]	2 600	3 000	2 x 52 [2 x 13.74]	2 x 60 [2 x 15.85]			61 [82]	90 [121]
	2 x 22 [2 x 1.34]	2 500	2 900	2 x 55 [2 x 14.53]	2 x 64 [2 x 16.91]			64 [86]	96 [129]
	2 x 25 [2 x 1.52]	2 400	2 800	2 x 60 [2 x 15.85]	2 x 70 [2 x 18.49]			70 [94]	105 [141]
	2 x 28.5 [2 x 1.74]	2 300	2 600	2 x 65 [2 x 17.17]	2 x 74 [2 x 19.55]			76 [102]	111 [149]
	2 x 32 [2 x 1.95]	2 100	2 400	2 x 67 [2 x 17.70]	2 x 77 [2 x 20.34]			78 [105]	115 [155]
3H14	3 x 17.5 [3 x 1.07]	2 900	3 400	3 x 51 [3 x 13.47]	3 x 60 [3 x 15.85]	350 [5 076]	450 [6 527]	89 [120]	134 [180]
	3 x 20 [3 x 1.22]	2 800	3 200	3 x 56 [3 x 14.79]	3 x 64 [3 x 16.91]			98 [132]	144 [194]
	3 x 22 [3 x 1.34]	2 700	3 100	3 x 59 [3 x 15.59]	3 x 68 [3 x 17.96]			104 [140]	153 [206]
	3 x 25 [3 x 1.52]	2 550	3 000	3 x 64 [3 x 16.91]	3 x 75 [3 x 19.81]			112 [151]	169 [227]
	3 x 28.5 [3 x 1.74]	2 400	2 800	3 x 68 [3 x 17.96]	3 x 80 [3 x 21.13]			119 [160]	180 [242]
	3 x 32 [3 x 1.95]	2 200	2 500	3 x 70 [3 x 18.49]	3 x 80 [3 x 21.13]			123 [165]	180 [242]
4H10	4 x 10.3 [4 x 0.63]	2 500	2 700	4 x 26 [4 x 6.87]	4 x 28 [4 x 7.40]	350 [5 076]	450 [6 527]	59 [79]	84 [113]
	4 x 12.5 [4 x 0.76]	2 400	2 700	4 x 30 [4 x 7.93]	4 x 34 [4 x 8.98]			70 [94]	102 [137]
4H14	4 x 17.5 [4 x 1.07]	2 700	3 100	4 x 47 [4 x 12.42]	4 x 54 [4 x 14.27]	350 [5 076]	450 [6 527]	110 [148]	163 [219]
	4 x 20 [4 x 1.22]	2 500	2 900	4 x 50 [4 x 13.74]	4 x 58 [4 x 15.32]			117 [157]	174 [234]
	4 x 22 [4 x 1.34]	2 400	2 800	4 x 53 [4 x 14.53]	4 x 62 [4 x 16.38]			123 [165]	185 [249]
	4 x 25 [4 x 1.52]	2 300	2 600	4 x 57 [4 x 15.06]	4 x 65 [4 x 17.17]			134 [180]	195 [262]
	4 x 28.5 [4 x 1.74]	2 100	2 400	4 x 60 [4 x 15.85]	4 x 68 [4 x 17.96]			140 [188]	205 [276]
	4 x 32 [4 x 1.95]	1 900	2 200	4 x 61 [4 x 16.11]	4 x 70 [4 x 18.49]			142 [191]	211 [284]
4H18	4 x 33 [4 x 2.01]	2 300	2 500	4 x 74 [4 x 19.55]	4 x 82 [4 x 21.66]	300 [4 351]	450 [6 527]	152 [204]	246 [331]
	4 x 44 [4 x 2.68]	2 300	2 500	4 x 101 [4 x 26.68]	4 x 110 [4 x 29.06]			210 [282]	330 [444]
4H20	4 x 52 [4 x 3.17]	2 200	2 400	4 x 114 [4 x 30.12]	4 x 125 [4 x 33.02]	350 [5 076]	450 [6 527]	237 [319]	376 [506]
	4 x 58 [4 x 3.54]	2 200	2 400	4 x 128 [4 x 33.81]	4 x 139 [4 x 36.72]			299 [402]	417 [561]
6H14	6 x 17.5 [6 x 1.07]	2 800	3 200	6 x 49 [6 x 12.94]	6 x 56 [6 x 14.79]	350 [5 076]	450 [6 527]	171 [230]	252 [339]
	6 x 20 [6 x 1.22]	2 600	3 000	6 x 52 [6 x 13.74]	6 x 60 [6 x 15.85]			182 [245]	270 [363]
	6 x 22 [6 x 1.34]	2 400	2 800	6 x 53 [6 x 14.00]	6 x 62 [6 x 16.38]			185 [249]	277 [372]
	6 x 25 [6 x 1.52]	2 300	2 700	6 x 57 [6 x 15.06]	6 x 67 [6 x 17.70]			201 [270]	304 [409]
	6 x 28.5 [6 x 1.74]	2 200	2 500	6 x 63 [6 x 16.64]	6 x 71 [6 x 18.76]			219 [294]	320 [430]
	6 x 32 [6 x 1.95]	2 000	2 300	6 x 64 [6 x 16.91]	6 x 74 [6 x 19.55]			224 [301]	331 [445]
6H20	6 x 58 [6 x 3.54]	2 200	2 400	6 x 128 [6 x 33.81]	6 x 139 [6 x 36.72]	350 [5 076]	450 [6 527]	449 [604]	626 [842]
	6 x 65 [6 x 3.96]	2 000	2 200	6 x 130 [6 x 34.34]	6 x 143 [6 x 37.78]			455 [612]	643 [864]
	6 x 74 [6 x 4.51]	1 800	2 000	6 x 133 [6 x 35.13]	6 x 148 [6 x 39.10]			465 [625]	666 [895]

Cont.: Continuous operation.
Int.: Intermittent operation.
(*): Theoretical data.



Efficiency values must be taken into account when calculating the power absorbed by the pump.

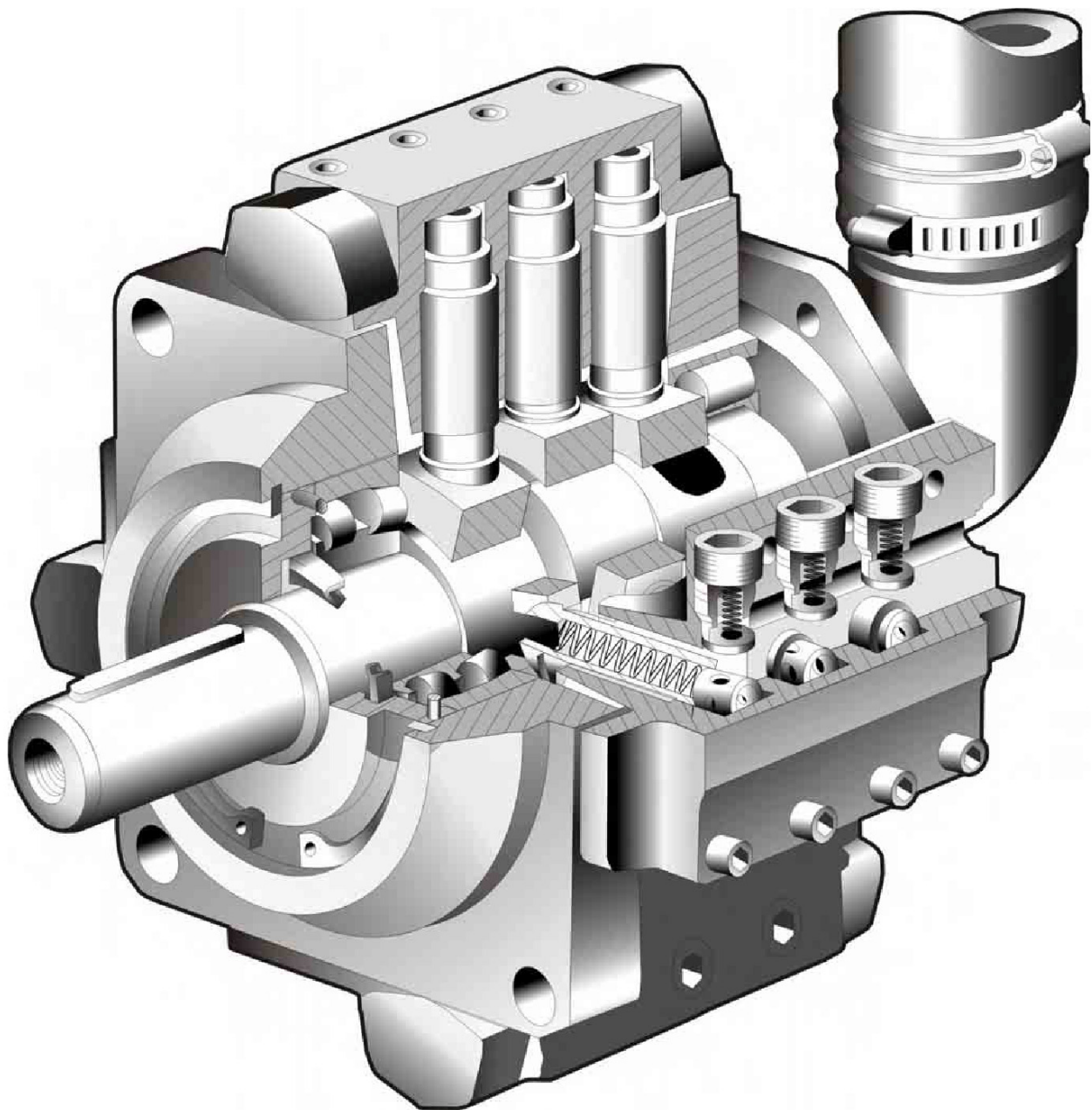

Methodology :

This document is intended for manufacturers of machines that incorporate Poclairn Hydraulics products. It describes the technical characteristics of Poclairn Hydraulics products and specifies installation conditions that will ensure optimum operation. This document includes important comments concerning safety. They are indicated in the following way:



Safety comment.

This document also includes essential operating instructions for the product and general information. These are indicated in the following way:



Essential instructions.



General information .



Information on the model number.



Weight of component without oil.



Volume of oil.



Units.



Tightening torque.



Screws.





Information intended for Poclairn-Hydraulics personnel.

The views in this document are created using metric standards.
The dimensional data is given in mm and in inches (inches are between brackets and italic)

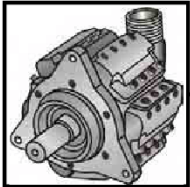

CONTENT

	MODEL CODE	7	Model code
	PUMP WITH 2 INDEPENDENT FLOWS	8	PL 2
	PUMP WITH 3 INDEPENDENT FLOWS	10	PL 3
	PUMP WITH 4 INDEPENDENT FLOWS	12	PL 4
	PUMP WITH 6 INDEPENDENT FLOWS	20	PL 6
	INSTALLATION	25	Installation

MODEL CODE

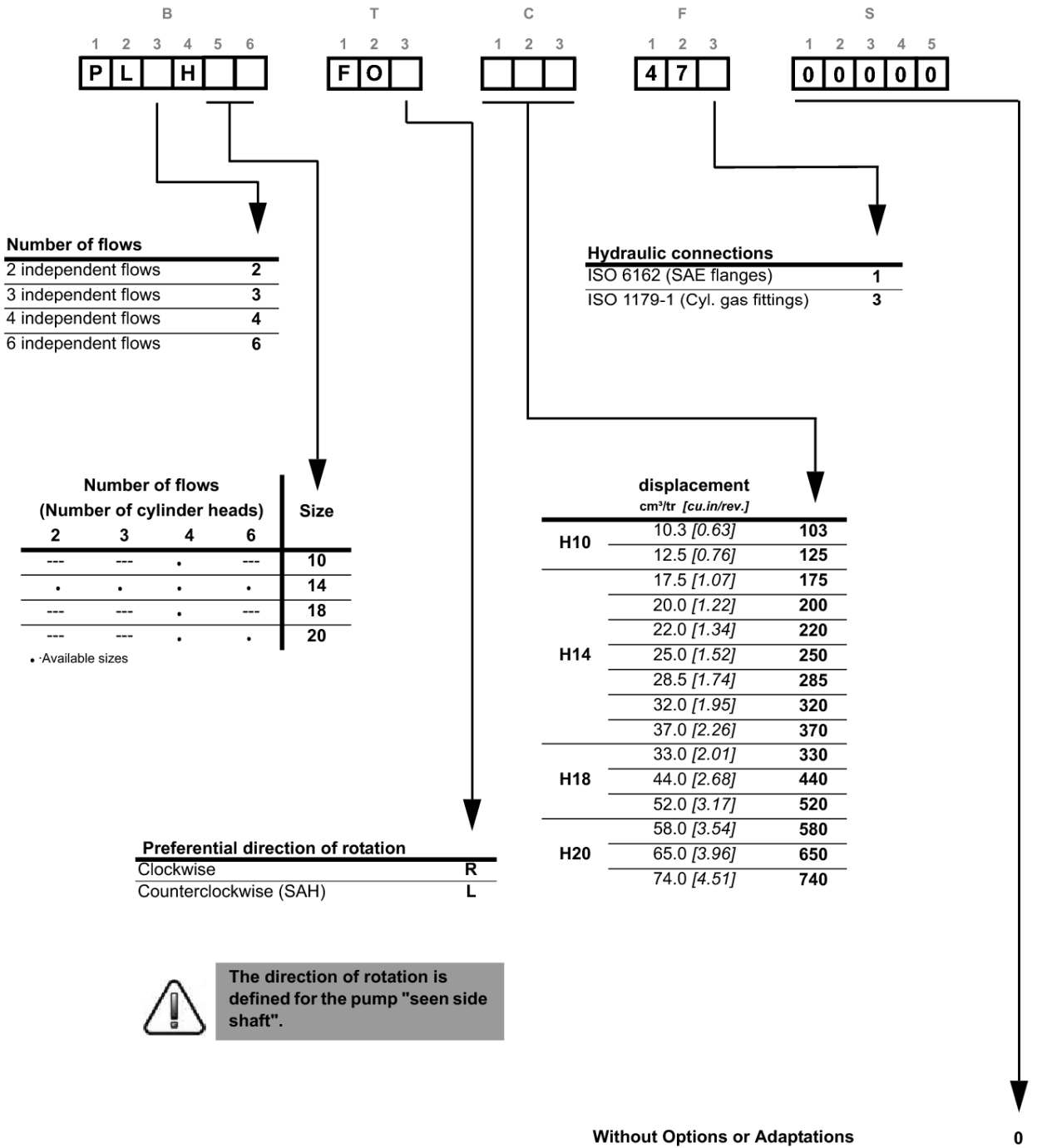

PUMP WITH 2 INDEPENDENT FLOWS

B	T	C	F	S
1 2 3 4 5 6	1 2 3	1 2 3	1 2 3	1 2 3 4 5
P L 2 H 1 4	F O		4 7 3	0 0 0 0 0

	2H14
	38 kg [83.8 lb]
inertia	0.0026 kg.m ²

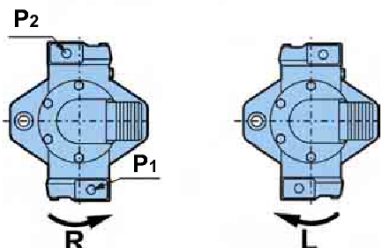
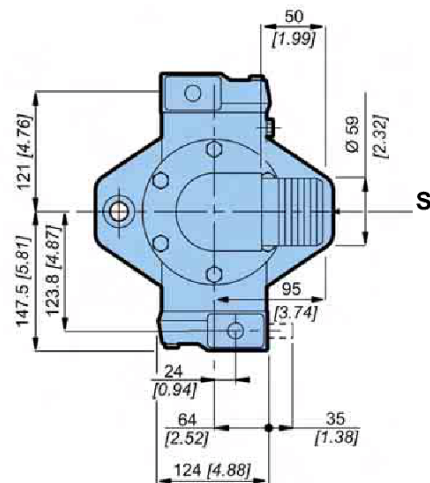
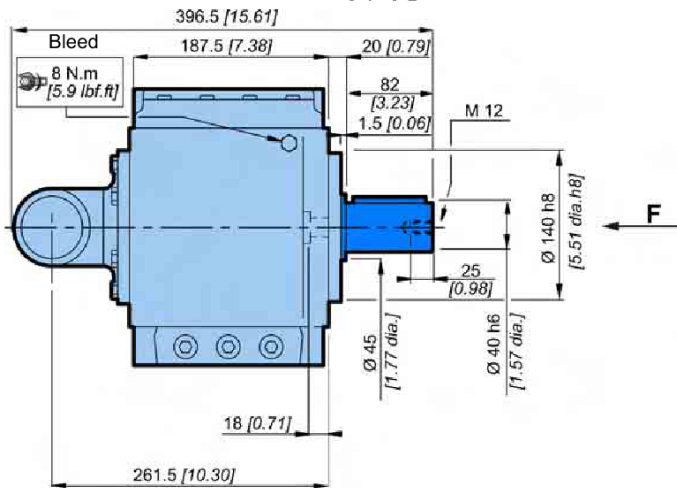

If possible, use the standard direction of rotation: clockwise (counterclockwise available as an option). The direction of rotation is indicated by an arrow on the cylinder head. The position of the discharge ports differs according to the direction of rotation.

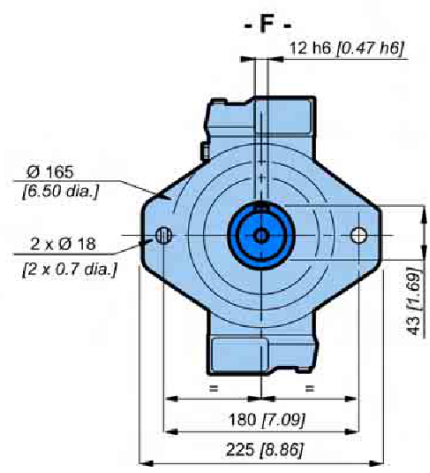

Hydraulic connections

	Displacement cm ³ /tr [cu.in/rev.]	Old standards	Standards	Hydraulic connections
2H14	1 2 x 17.5 [2 x 1.07]	BSPP	ISO 1179-1	Ø 21 [1/2" dia.]
	2 2 x 20 [2 x 1.22]			
	3 2 x 22 [2 x 1.34]			
	4 2 x 25 [2 x 1.52]	BSPP	ISO 1179-1	Ø 27 [3/4" dia.]
	5 2 x 28.5 [2 x 1.74]			
	6 2 x 32 [2 x 1.95]			

Characteristics

	Max. speed tr/min [RPM]		Flow l/min [GPM]		Max. pressure bar [PSI]		Max. power kW [HP]		
	Cont.	int.	Cont.	int.	Cont.	int.	Cont.	int.	
2H14	1	2 700	3 100	2 x 47 [2 x 12.42]	2 x 54 [2 x 14.27]	350 [5 076]	450 [6 527]	55 [74]	81 [109]
	2	2 600	3 000	2 x 52 [2 x 13.74]	2 x 60 [2 x 15.85]			61 [82]	90 [121]
	3	2 500	2 900	2 x 55 [2 x 14.53]	2 x 64 [2 x 16.91]			64 [86]	96 [129]
	4	2 400	2 800	2 x 60 [2 x 15.85]	2 x 70 [2 x 18.49]			70 [94]	105 [141]
	5	2 300	2 600	2 x 65 [2 x 17.17]	2 x 74 [2 x 19.55]			76 [102]	111 [149]
	6	2 100	2 400	2 x 67 [2 x 17.70]	2 x 77 [2 x 20.34]			78 [105]	115 [155]

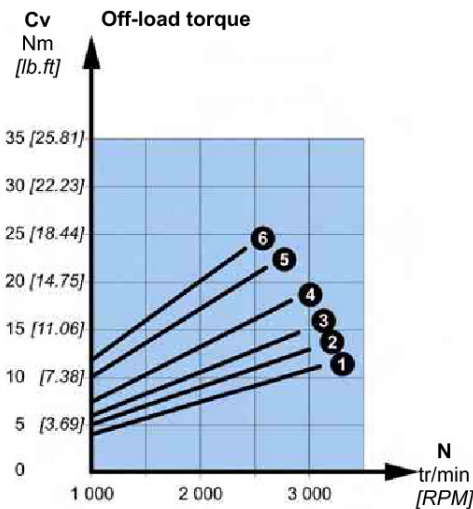
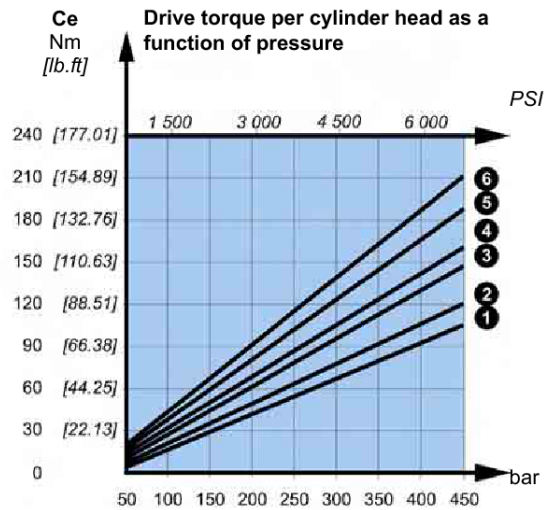
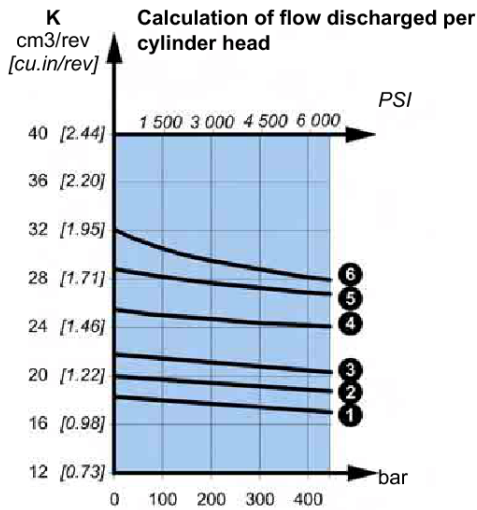

Absorbed power

- P = Absorbed power (kW)
- Cv = Off-load torque (Nm)
- Ce = Drive torque per body (Nm)
- n = number of bodies
- N = Speed of rotation (RPM)

$$P = \frac{[Cv + (Ce \times n)] \times N}{954}$$

Flow

- K = Effective displacement taking into account the compressibility of oil and the volumetric efficiency (cm3/rev)
- N = Speed of rotation (RPM)
- Q = Flow per body (l/min)

$$Q = \frac{K \times N}{1000}$$



Convert the final result to obtain the power in HP.

PUMP WITH 3 INDEPENDENT FLOWS

B						T			C			F			S				
1	2	3	4	5	6	1	2	3	1	2	3	1	2	3	1	2	3	4	5
P	L	3	H	1	4	F	O					4	7	3	0	0	0	0	0

	3H14
	47 kg [103.6 lb]
inertia	0.0026 kg.m ²

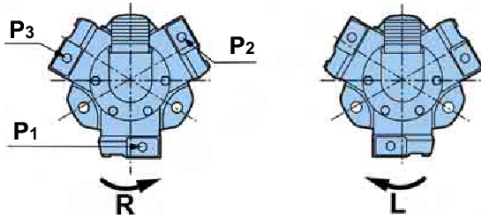
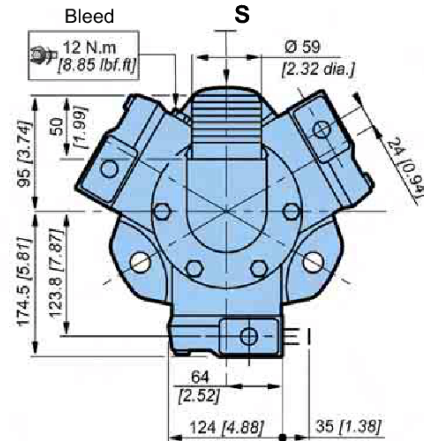
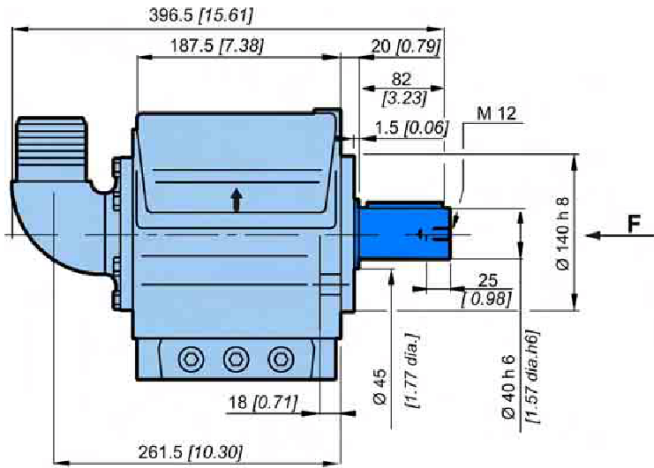

If possible, use the standard direction of rotation: clockwise (counterclockwise available as an option).
 The direction of rotation is indicated by an arrow on the cylinder head.
 The position of the discharge ports differs according to the direction of rotation.

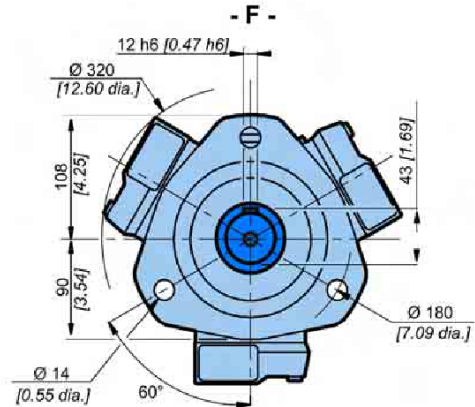

Hydraulic connections

	Displacement cm ³ /tr [cu.in/rev.]	Old standards	Standards	Hydraulic connections
3H14	1 3 x 17.5 [3 x 1.07]	BSPP	ISO 1179-1	Ø 21 [1/2" dia.]
	2 3 x 20 [3 x 1.22]			
	3 3 x 22 [3 x 1.34]			
	4 3 x 25 [3 x 1.52]	BSPP	ISO 1179-1	Ø 27 [3/4" dia.]
	5 3 x 28.5 [3 x 1.74]			
	6 3 x 32 [3 x 1.95]			
	7 3 x 37 [3 x 2.26]			

Characteristics

	Max. speed tr/min [RPM]		Flow l/min [GPM]		Max. pressure bar [PSI]		Max. power kW [HP]		
	Cont.	int.	Cont.	int.	Cont.	int.	Cont.	int.	
3H14	1	2 900	3 400	3 x 51 [3 x 13.47]	3 x 60 [3 x 15.85]	350 [5 076]	450 [6 527]	89 [120]	134 [180]
	2	2 800	3 200	3 x 56 [3 x 14.79]	3 x 64 [3 x 16.91]			98 [132]	144 [194]
	3	2 700	3 100	3 x 59 [3 x 15.59]	3 x 68 [3 x 17.96]			104 [140]	153 [206]
	4	2 550	3 000	3 x 64 [3 x 16.91]	3 x 75 [3 x 19.81]			112 [151]	169 [227]
	5	2 400	2 800	3 x 68 [3 x 17.96]	3 x 80 [3 x 21.13]			119 [160]	180 [242]
	6	2 200	2 500	3 x 70 [3 x 18.49]	3 x 80 [3 x 21.13]			123 [165]	180 [242]
	7	2 100	2 400	3 x 78 [3 x 20.61]	3 x 89 [3 x 23.51]			137 [184]	200 [269]

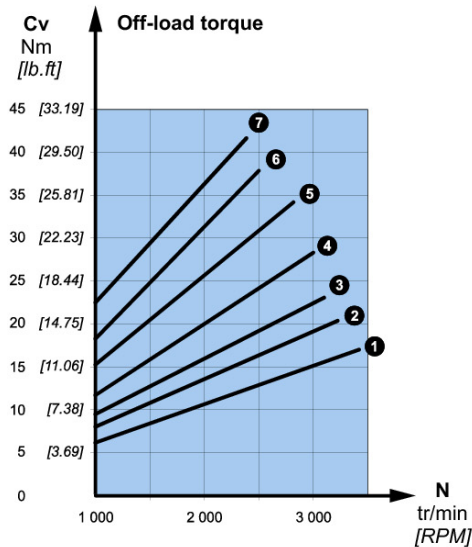
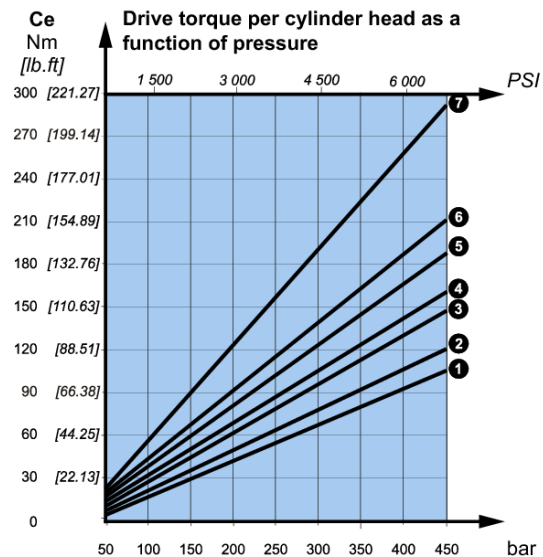
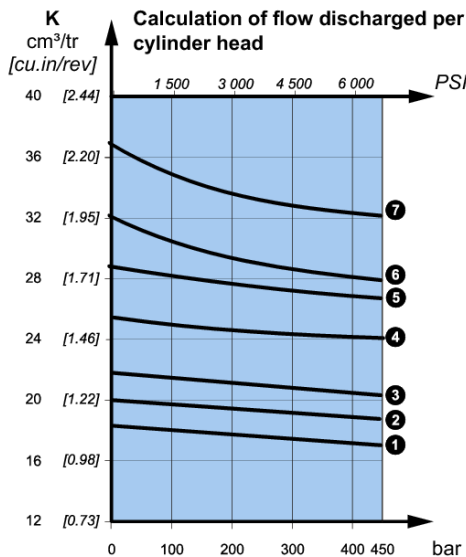

Absorbed power

- P = Absorbed power (kW)
- Cv = Off-load torque (Nm)
- Ce = Drive torque per body (Nm)
- n = number of bodies
- N = Speed of rotation (RPM)

$$P = \frac{[Cv + (Ce \times n)] \times N}{954}$$

Flow

- K = Effective displacement taking into account the compressibility of oil and the volumetric efficiency (cm³/rev)
- N = Speed of rotation (RPM)
- Q = Flow per body (l/min)

$$Q = \frac{K \times N}{1000}$$



Convert the final result to obtain the power in HP.

PUMP WITH 4 INDEPENDENT FLOWS

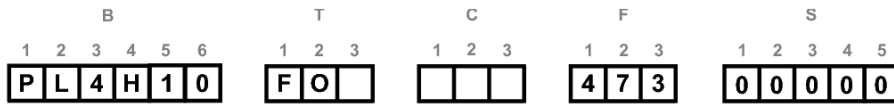

	4H10
	42 kg [93 lb]
inertia	0.0026 kg.m ²

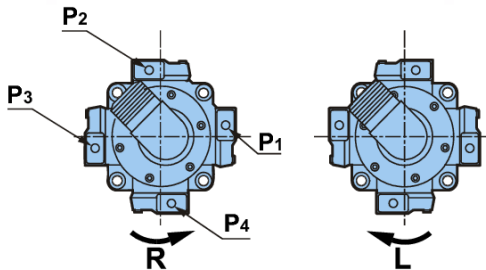
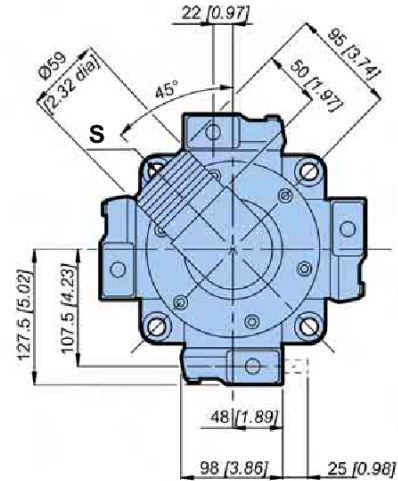
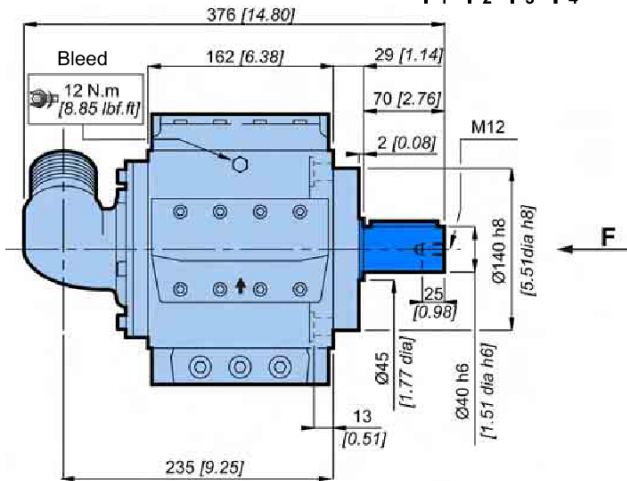
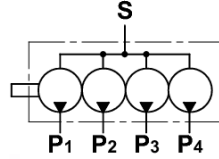

If possible, use the standard direction of rotation: clockwise (counterclockwise available as an option).
 The direction of rotation is indicated by an arrow on the cylinder head.
 The position of the discharge ports differs according to the direction of rotation.

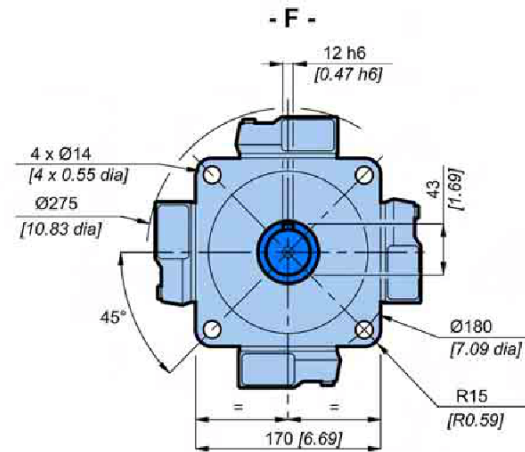

Hydraulic connections

	Displacement	Old standards	Standards	Hydraulic connections
	cm ³ /tr [cu.in/rev.]			
4H10	1 4 x 10.3 [4 x 0.63]	BSPP	ISO 1179-1	Ø17 [3/8" dia.]
	2 4 x 12.5 [4 x 0.76]			

Characteristics

	Max.speed tr/min [RPM]		Flow l/min [GPM]		Max. pressure bar [PSI]		Max.power kW [HP]		
	Cont.	int.	Cont.	int.	Cont.	int.	Cont.	int.	
4H10	1	2 500	2 700	4 x 26 [4 x 6.87]	4 x 28 [4 x 7.40]	350 [5 076]	450 [6 527]	59 [79]	84 [113]
	2	2 400	2 700	4 x 30 [4 x 7.93]	4 x 34 [4 x 8.98]			70 [94]	102 [137]

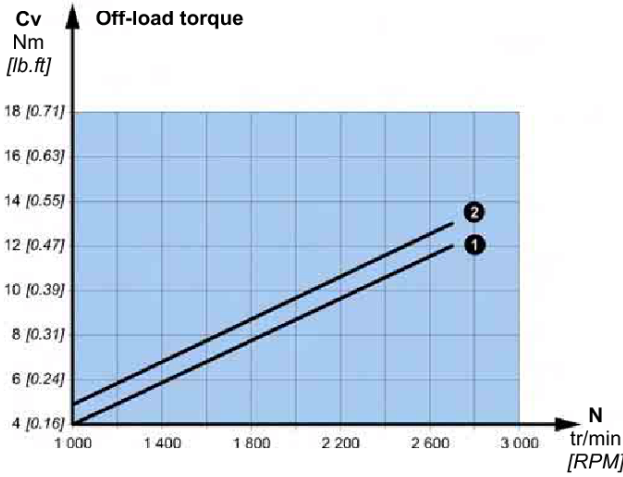
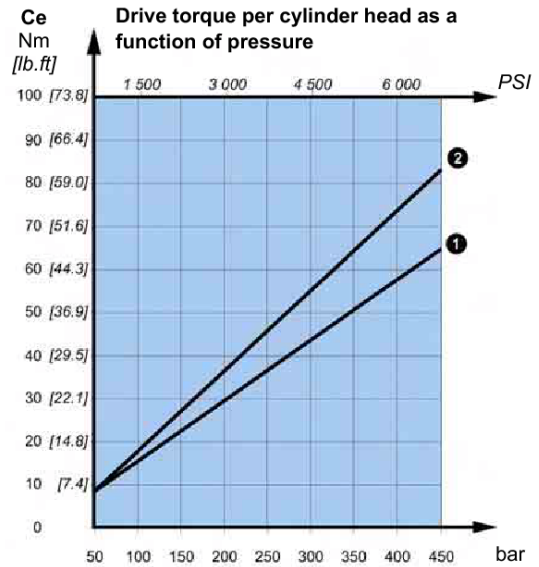
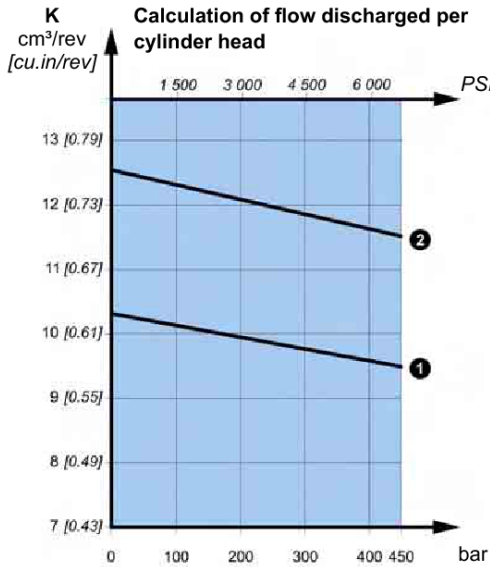

Absorbed power

- P = Absorbed power (kW)
- Cv = Off-load torque (Nm)
- Ce = Drive torque per body (Nm)
- n = number of bodies
- N = Speed of rotation (RPM)

$$P = \frac{[Cv + (Ce \times n)] \times N}{954}$$

Flow

- K = Effective displacement taking into account the compressibility of oil and the volumetric efficiency (cm³/rev)
- N = Speed of rotation (RPM)
- Q = Flow per body (l/min)

$$Q = \frac{K \times N}{1000}$$



Convert the final result to obtain the power in HP.

PUMP WITH 4 INDEPENDENT FLOWS

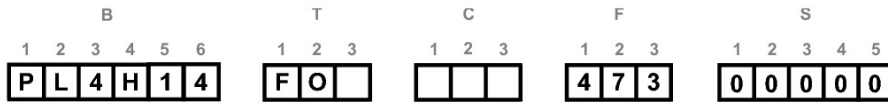

	4H14
	68 kg [150 lb]
inertia	0.0055 kg.m ²

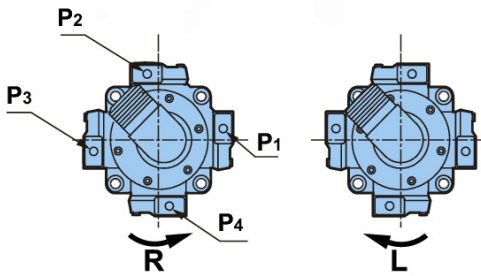
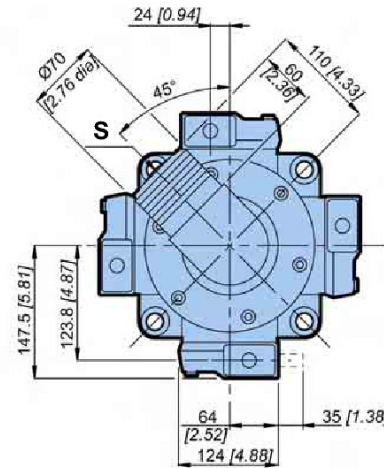
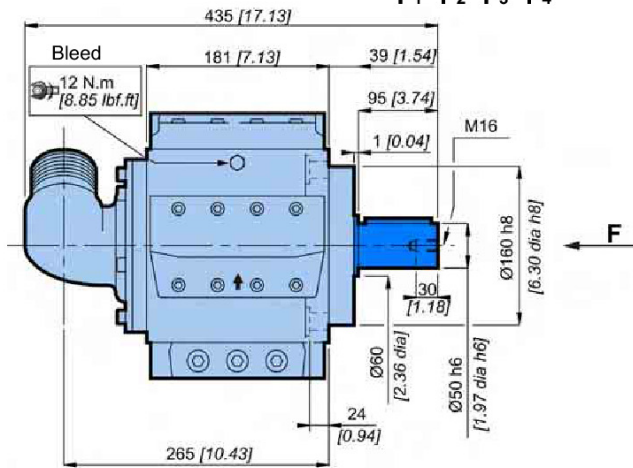
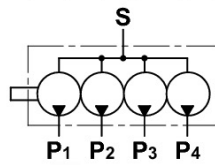

If possible, use the standard direction of rotation: clockwise (counterclockwise available as an option).
 The direction of rotation is indicated by an arrow on the cylinder head.
 The position of the discharge ports differs according to the direction of rotation.

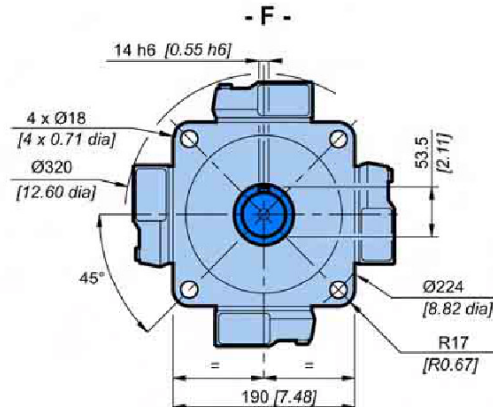

Hydraulic connections

	Displacement cm ³ /tr [cu.in/rev.]	Old standards	Standards	Hydraulic connections
4H14	1 4 x 17.5 [4 x 1.07]	BSPP	ISO 1179-1	Ø21 [1/2" dia.]
	2 4 x 20 [4 x 1.22]			
	3 4 x 22 [4 x 1.34]			
	4 4 x 25 [4 x 1.52]	BSPP	ISO 1179-1	Ø27 [3/4" dia.]
	5 4 x 28.5 [4 x 1.74]			
	6 4 x 32 [4 x 1.95]			
	7 4 x 37 [4 x 2.26]			

Characteristics

	Max. speed tr/min [RPM]		Flow l/min [GPM]		Max. pressure bar [PSI]		Max. power kW [HP]		
	Cont.	int.	Cont.	int.	Cont.	int.	Cont.	int.	
4H14	1	2 700	3 100	4 x 47 [4 x 12.42]	4 x 54 [4 x 14.27]	350 [5 076]	450 [6 527]	110 [148]	163 [219]
	2	2 500	2 900	4 x 50 [4 x 13.74]	4 x 58 [4 x 15.32]			117 [157]	174 [234]
	3	2 400	2 800	4 x 53 [4 x 14.53]	4 x 62 [4 x 16.38]			123 [165]	185 [249]
	4	2 300	2 600	4 x 57 [4 x 15.06]	4 x 65 [4 x 17.17]			134 [180]	195 [262]
	5	2 100	2 400	4 x 60 [4 x 15.85]	4 x 68 [4 x 17.96]			140 [188]	205 [276]
	6	1 900	2 200	4 x 61 [4 x 16.11]	4 x 70 [4 x 18.49]			142 [191]	211 [284]
	7	1 800	2 000	4 x 66 [4 x 17.44]	4 x 74 [4 x 18.49]			154 [207]	222 [298]

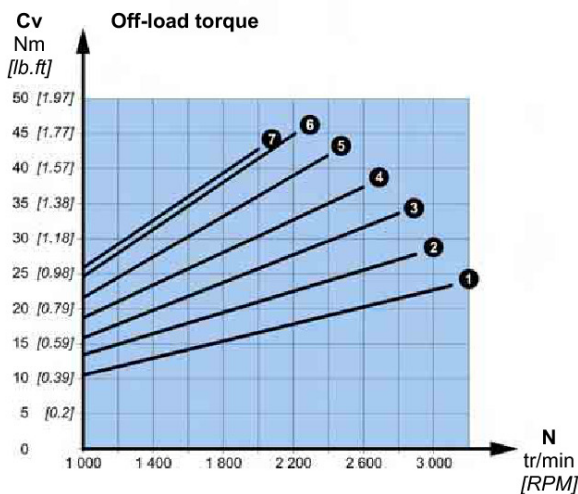
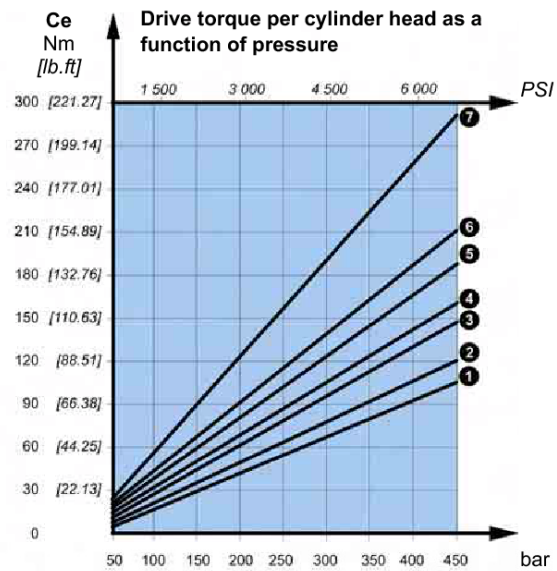
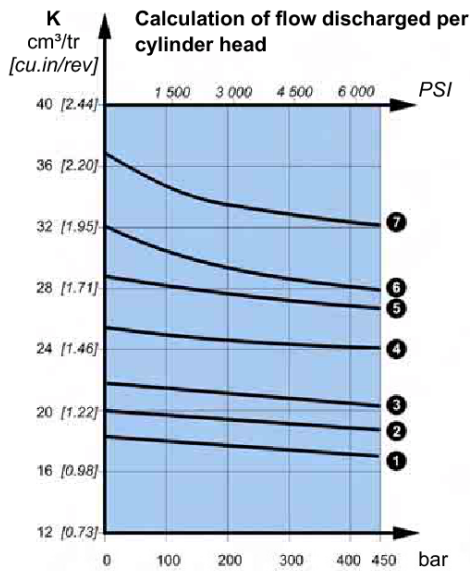

Absorbed power

- P = Absorbed power (kW)
- Cv = Off-load torque (Nm)
- Ce = Drive torque per body (Nm)
- n = number of bodies
- N = Speed of rotation (RPM)

$$P = \frac{[Cv + (Ce \times n)] \times N}{954}$$

Flow

- K = Effective displacement taking into account the compressibility of oil and the volumetric efficiency (cm³/rev)
- N = Speed of rotation (RPM)
- Q = Flow per body (l/min)

$$Q = \frac{K \times N}{1000}$$



Convert the final result to obtain the power in HP.

PUMP WITH 4 INDEPENDENT FLOWS

B

1 2 3 4 5 6

P L 4 H 1 8

T

1 2 3

F O

C

1 2 3

F

1 2 3

4 7

S

1 2 3 4 5

0 0 0 0 0

4H18
140 kg [309 lb]
inertia 0.035 kg.m²

If possible, use the standard direction of rotation: clockwise (counterclockwise available as an option). The direction of rotation is indicated by an arrow on the cylinder head. The position of the discharge ports differs according to the direction of rotation.

Hydraulic connections

B

1 2 3 4 5 6

P L 4 H 1 8

T

1 2 3

F O

C

1 2 3

F

1 2 3

4 7

S

1 2 3 4 5

0 0 0 0 0

		Displacement	Old standards	Standards	Hydraulic connections
		cm³/tr [cu.in/rev.]			
1	1	4 x 33 [4 x 2.01]	ISO 6162	ISO 6162	SAE ISO 6000 PSI 3/4"
	2	4 x 44 [4 x 2.68]			
	3	4 x 52 [4 x 3.17]			
3	1	4 x 33 [4 x 2.01]	BSPP	ISO 1179-1	Ø27 [3/4" dia.]
	2	4 x 44 [4 x 2.68]			
	3	4 x 52 [4 x 3.17]			

Characteristics

C	Max.speed tr/min [RPM]		Flow l/min [GPM]		Max. pressure bar [PSI]		Max.power kW [HP]		
	Cont.	int.	Cont.	int.	Cont.	int.	Cont.	int.	
4H18	①	2 300	2 500	4 x 74 [4 x 19.55]	4 x 82 [4 x 21.66]	300 [4 351]	450 [6 527]	152 [204]	246 [331]
	②	2 300	2 500	4 x 101 [4 x 26.68]	4 x 110 [4 x 29.06]			210 [282]	330 [444]
	③	2 200	2 400	4 x 114 [4 x 30.12]	4 x 125 [4 x 33.02]			237 [319]	376 [506]

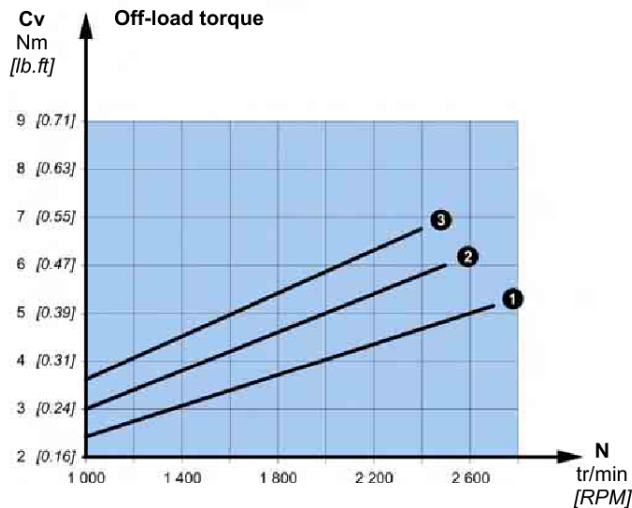
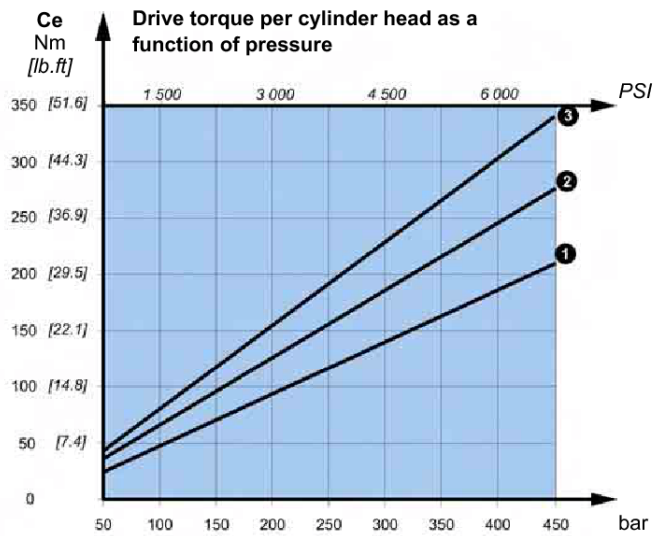
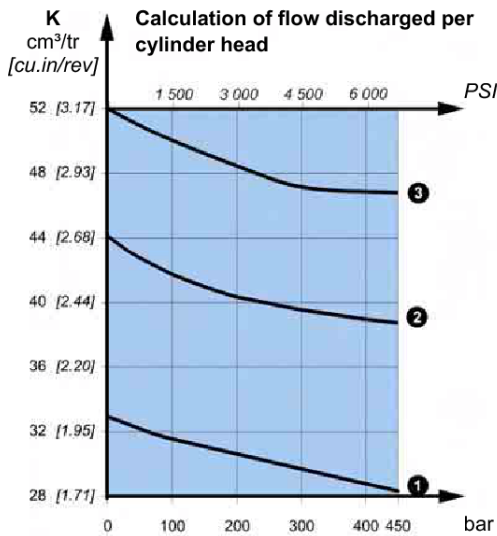

Absorbed power

- P = Absorbed power (kW)
- Cv = Off-load torque (Nm)
- Ce = Drive torque per body (Nm)
- n = number of bodies
- N = Speed of rotation (RPM)

$$P = \frac{[Cv + (Ce \times n)] \times N}{954}$$

Flow

- K = Effective displacement taking into account the compressibility of oil and the volumetric efficiency (cm³/rev)
- N = Speed of rotation (RPM)
- Q = Flow per body (l/min)

$$Q = \frac{K \times N}{1000}$$



Convert the final result to obtain the power in HP.

PUMP WITH 4 INDEPENDENT FLOWS

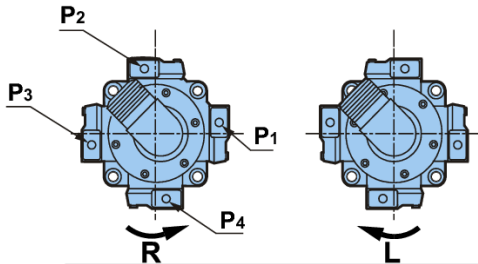
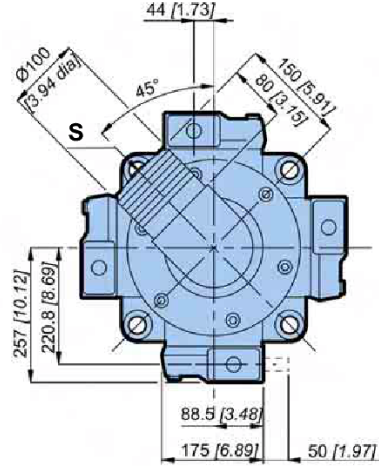
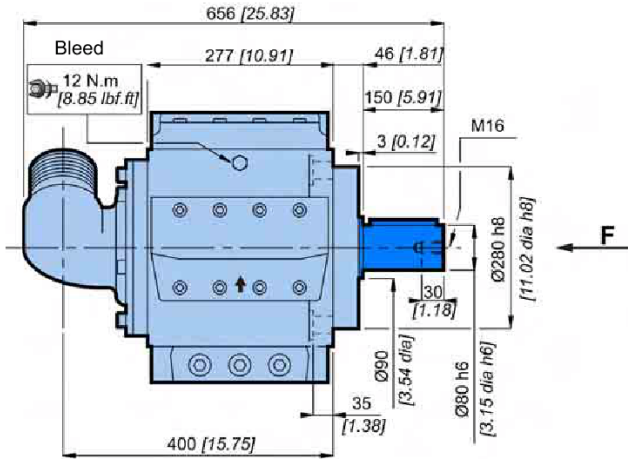
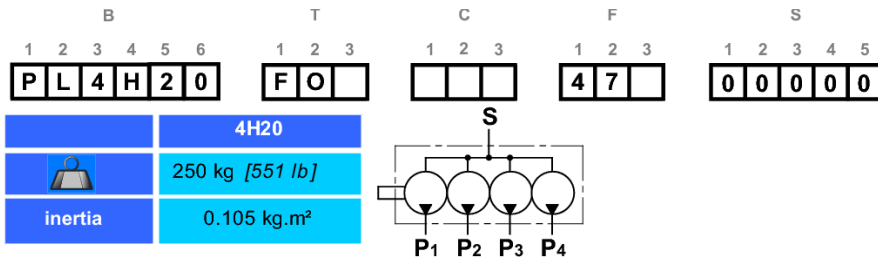

If possible, use the standard direction of rotation: clockwise (counterclockwise available as an option).
 The direction of rotation is indicated by an arrow on the cylinder head.
 The position of the discharge ports differs according to the direction of rotation.

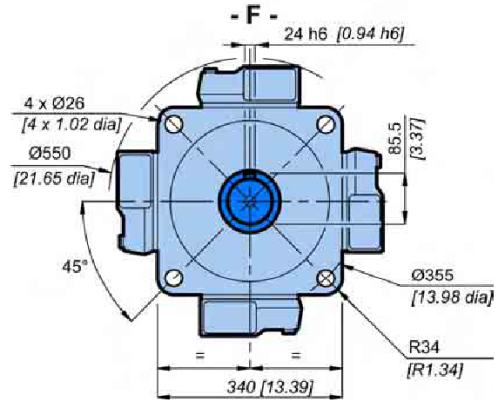

Hydraulic connections



	Displacement	Old standards	Standards	Hydraulic connections
	cm ³ /tr [cu.in/rev.]			
1	① 4 x 58 [4 x 3.54]	ISO 6162	ISO 6162	SAE ISO 6000 PSI 1"
	② 4 x 74 [4 x 4.51]			
3	① 4 x 58 [4 x 3.54]	BSPP	ISO 1179-1	Ø34 [1" dia.]
	② 4 x 74 [4 x 4.51]			

Characteristics

	Max. speed tr/min [RPM]		Flow l/min [GPM]		Max. pressure bar [PSI]		Max. power kW [HP]		
	Cont.	int.	Cont.	int.	Cont.	int.	Cont.	int.	
4H20	1	2 200	2 400	4 x 128 [4 x 33.81]	4 x 139 [4 x 36.72]	350 [5 076]	450 [6 527]	299 [402]	417 [561]
	2	2 100	2 300	4 x 155 [4 x 40.95]	4 x 170 [4 x 44.91]			362 [487]	510 [686]

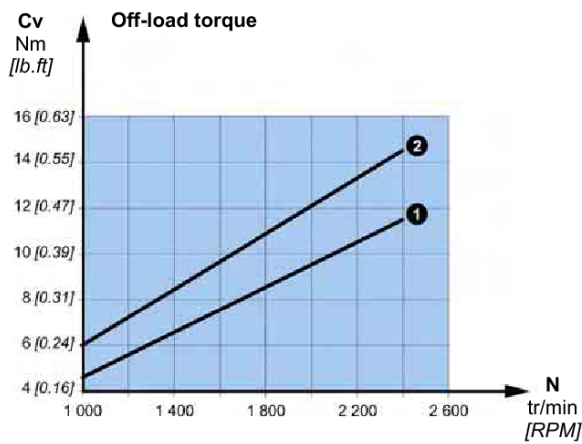
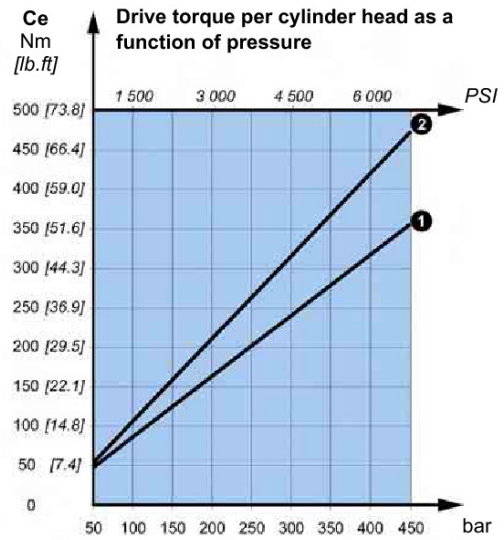
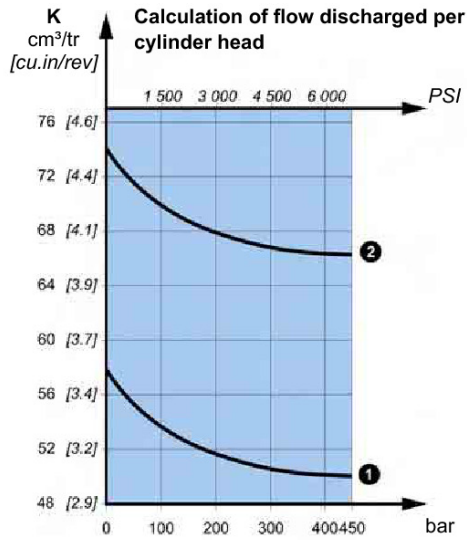

Absorbed power

- P = Absorbed power (kW)
- Cv = Off-load torque (Nm)
- Ce = Drive torque per body (Nm)
- n = number of bodies
- N = Speed of rotation (RPM)

$$P = \frac{[Cv + (Ce \times n)] \times N}{954}$$

Flow

- K = Effective displacement taking into account the compressibility of oil and the volumetric efficiency (cm³/rev)
- N = Speed of rotation (RPM)
- Q = Flow per body (l/min)

$$Q = \frac{K \times N}{1000}$$



Convert the final result to obtain the power in HP.

PUMP WITH 6 INDEPENDENT FLOWS

B

1 2 3 4 5 6

P L 6 H 1 4

I

1 2 3

F O

C

1 3

F

1 2 2 3

4 7 3

S

1 2 3 4 5

0 0 0 0 0

	6H14
	84 kg [185 lb]
inertia	0.012 kg.m²

If possible, use the standard direction of rotation: clockwise (counterclockwise available as an option).
 The direction of rotation is indicated by an arrow on the cylinder head.
 The position of the discharge ports differs according to the direction of rotation.

Hydraulic connections

		Displacement <i>cm³/tr [cu.in/rev.]</i>	Old standards	Standards	Hydraulic connections
6H14	1	6 x 17.5 [6 x 1.07]	BSPP	ISO 1179-1	Ø21 [1/2" dia.]
	2	6 x 20 [6 x 1.22]			
	3	6 x 22 [6 x 1.34]			
	4	6 x 25 [6 x 1.52]	BSPP	ISO 1179-1	Ø27 [3/4" dia.]
	5	6 x 28.5 [6 x 1.74]			
	6	6 x 32 [6 x 1.95]			

Characteristics

	Max. speed tr/min [RPM]		Flow l/min [GPM]		Max. pressure bar [PSI]		Max. power kW [HP]		
	Cont.	int.	Cont.	int.	Cont.	int.	Cont.	int.	
6H14	1	2 800	3 200	6 x 49 [6 x 12.94]	6 x 56 [6 x 14.79]	350 [5 076]	450 [6 527]	171 [230]	252 [339]
	2	2 600	3 000	6 x 52 [6 x 13.74]	6 x 60 [6 x 15.85]			182 [245]	270 [363]
	3	2 400	2 800	6 x 53 [6 x 14.00]	6 x 62 [6 x 16.38]			185 [249]	277 [372]
	4	2 300	2 700	6 x 57 [6 x 15.06]	6 x 67 [6 x 17.70]			201 [270]	304 [409]
	5	2 200	2 500	6 x 63 [6 x 16.64]	6 x 71 [6 x 18.76]			219 [294]	320 [430]
	6	2 000	2 300	6 x 64 [6 x 16.91]	6 x 74 [6 x 19.55]			224 [301]	331 [445]

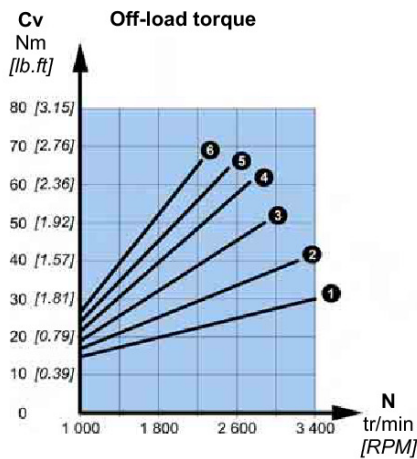
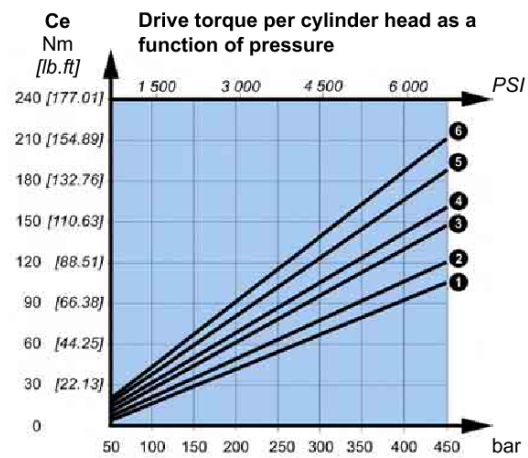
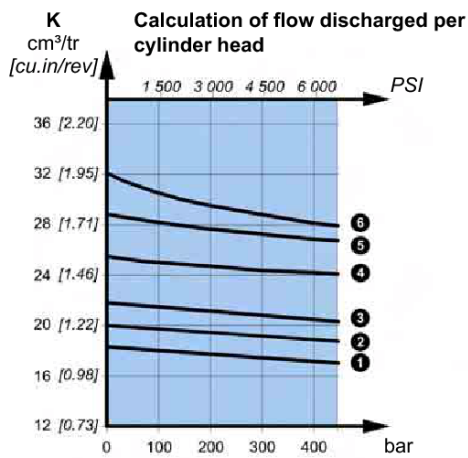

Absorbed power

- P = Absorbed power (kW)
- Cv = Off-load torque (Nm)
- Ce = Drive torque per body (Nm)
- n = number of bodies
- N = Speed of rotation (RPM)

$$P = \frac{[Cv + (Ce \times n)] \times N}{954}$$

Flow

- K = Effective displacement taking into account the compressibility of oil and the volumetric efficiency (cm³/rev)
- N = Speed of rotation (RPM)
- Q = Flow per body (l/min)

$$Q = \frac{K \times N}{1000}$$



Convert the final result to obtain the power in HP.

PUMP WITH 6 INDEPENDENT FLOWS

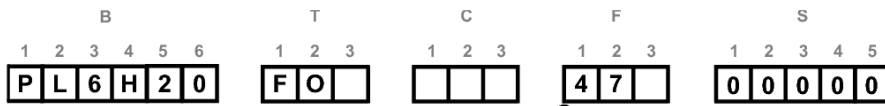

	6H20
	360 kg [794 lb]
inertia	0.105 kg.m²

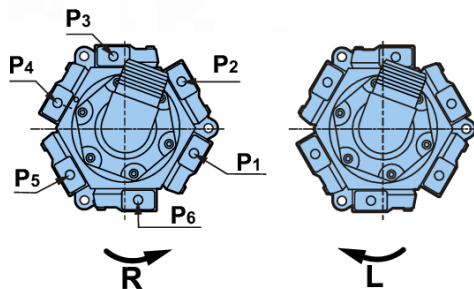
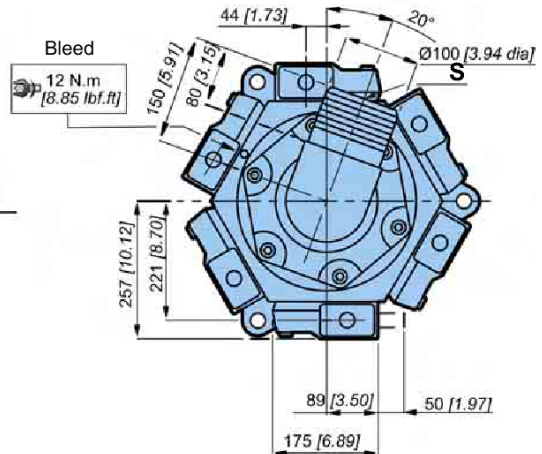
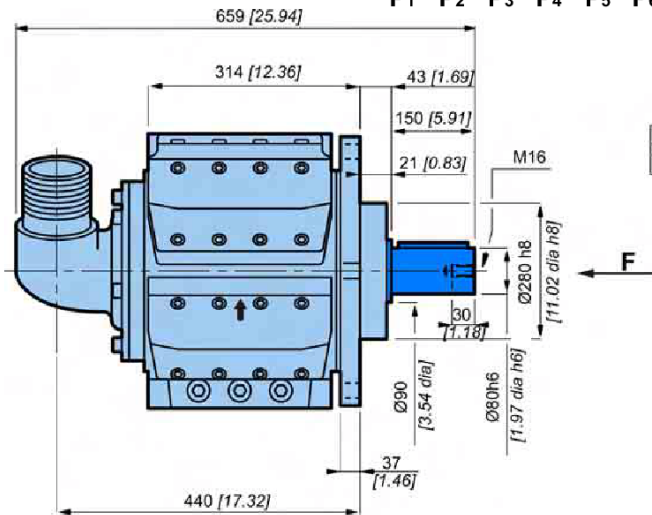
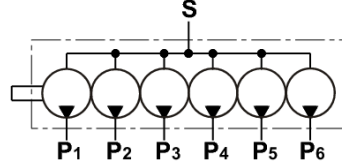

If possible, use the standard direction of rotation: clockwise (counterclockwise available as an option).
 The direction of rotation is indicated by an arrow on the cylinder head.
 The position of the discharge ports differs according to the direction of rotation.

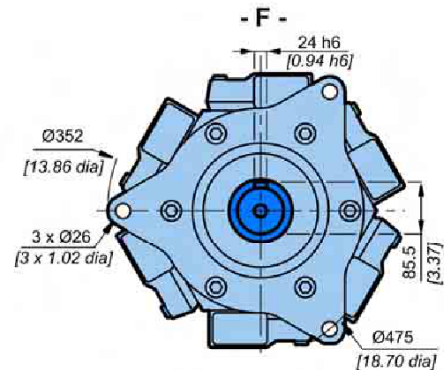

		Displacement	Old standards	Standards	Hydraulic connections
1	1	6 x 58 [6 x 3.54]	ISO 6162	ISO 6162	SAE ISO 6000 PSI 1"
	2	6 x 65 [6 x 3.96]			
	3	6 x 74 [6 x 4.51]			
3	1	6 x 58 [6 x 3.54]	BSPP	ISO 1179-1	Ø34 [1" dia.]
	2	6 x 65 [6 x 3.96]			
	3	6 x 74 [6 x 4.51]			

Characteristics

	Max. speed tr/min [RPM]		Flow l/min [GPM]		Max. pressure bar [PSI]		Max. power kW [HP]		
	Cont.	int.	Cont.	int.	Cont.	int.	Cont.	int.	
6H20	①	2 200	2 400	6 x 128 [6 x 33.81]	6 x 139 [6 x 36.72]	350 [5 076]	450 [6 527]	449 [604]	626 [842]
	②	2 000	2 200	6 x 130 [6 x 34.34]	6 x 143 [6 x 37.78]			455 [612]	643 [864]
	③	1 800	2 000	6 x 133 [6 x 35.13]	6 x 148 [6 x 39.10]			465 [625]	666 [895]

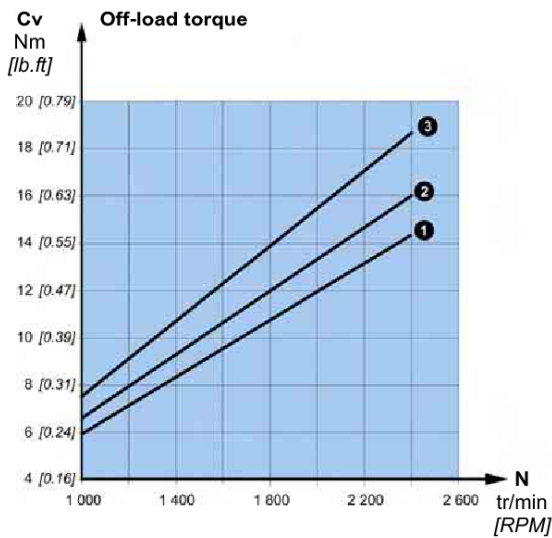
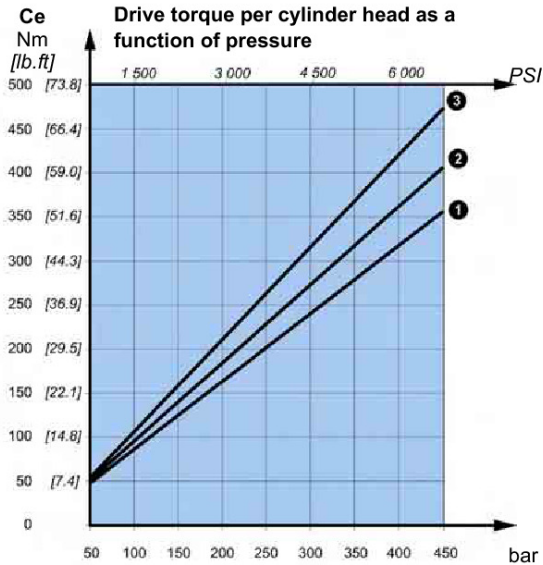
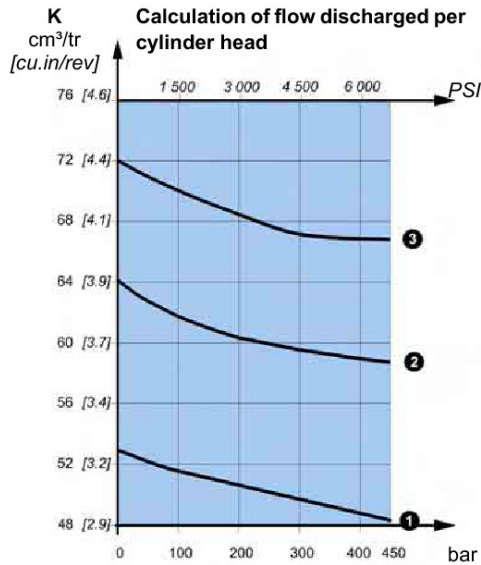

Absorbed power

- P = Absorbed power (kW)
- Cv = Off-load torque (Nm)
- Ce = Drive torque per body (Nm)
- n = number of bodies
- N = Speed of rotation (RPM)

$$P = \frac{[Cv + (Ce \times n)] \times N}{954}$$

Flow

- K = Effective displacement taking into account the compressibility of oil and the volumetric efficiency (cm³/rev)
- N = Speed of rotation (RPM)
- Q = Flow per body (l/min)

$$Q = \frac{K \times N}{1000}$$



Convert the final result to obtain the power in HP.

INSTALLATION

Warnings

Before Installation



Take all necessary safety precautions (people and machines) and comply with safety regulations in effect.



Confirm that mobile equipment is immobilized.



Confirm that the hydraulic systems' energy generator (motor) is stopped and electric power is disconnected.



Lay out a safety perimeter.



Do not perform work on a hydraulic system that is hot or under pressure (discharge the accumulators).



Oil that is hot or under pressure can cause serious burns and infection. Consult a physician in case of accident.

During Installation

Install the hydraulic system according to the specifications and processes appearing in this document.



Support the components using a lifting device whose capacity is adequate for attaching the components to the chassis.



During handling protect all sensitive surfaces from shocks (centerings, bolts, connectors, plugs, etc.).



Confirm that the components' centering and support surfaces on the chassis are clean (free of paint).



Never heat hydraulic fluid which can ignite at high temperature. Some solvents are also inflammable.



Do not smoke while working on the system.

After Installation



The immediate vicinity of the machine should be declared a security zone. Observe all regulations regarding personnel safety.

OVERVIEW

Component Identification



- A** : Sales code:
Ex. PL3H15-FOR-250-472-00000
- B** : Code (Item Code):
Ex. L15435-63
- C** :
Series (Manufacturing number):
- D** : Num (Chronological sequence number)
- E** : Country of Manufacture.
- F** : Manufacturing location.



The item code and sequence number must appear on each spare parts order.

Delivery



In boxes.



Without oil.



Painted with primer.



With protected openings (Plastic/metallic plugs or plates with joints for the flanges, sealing them).

With protected attachment surfaces (these surfaces are never painted), they are covered with a thin film of varnish to limit any oxidation.

Storage

If this is not possible, follow the recommendations below in order to avoid damage to sensitive parts.

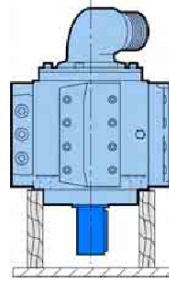

No contact with the shaft.

Storage Interval

Depending on the interval and storage conditions, it is necessary to protect the internal components of the hydraulic parts. These operations must be performed before storing components or before stopping use of the machine.

Climate	Storage interval (months)			
	3	6	12	24
Temperate	A	B	C	C
Tropical	B	C	D	D
	C	D	D	D

Legend

- A** - No specific precaution; only check the proper mounting of the plugs and covers.
- B** - Fill up with hydraulic fluid
- C** - Rinse with storage fluid
- D** - Fill up with storage fluid.



Open air storage areas must not be used. The pumps must not be placed directly on the ground.

Paint

- Leave the bearing surfaces unpainted.
- Use paints compatible with the existing base coat.
- The Poclairn Hydraulics components (like any mechanical component) can rust. They must be effectively and regularly protected according to the environment where they are used. During installation of the motors, any trace of rust must be eliminated before painting the machine.

Primer Specifications

Number	Color	Brilliance	Saline mist	Adhesion	Hardness
		ISO 2813	ISO 9227	ISO 2409	ASTM D3363
RAL 7016	Grey	5 - 10%	> 400 h	0	HB

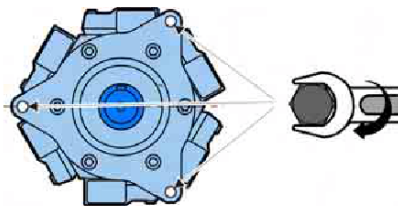

Attachment to the Chassis

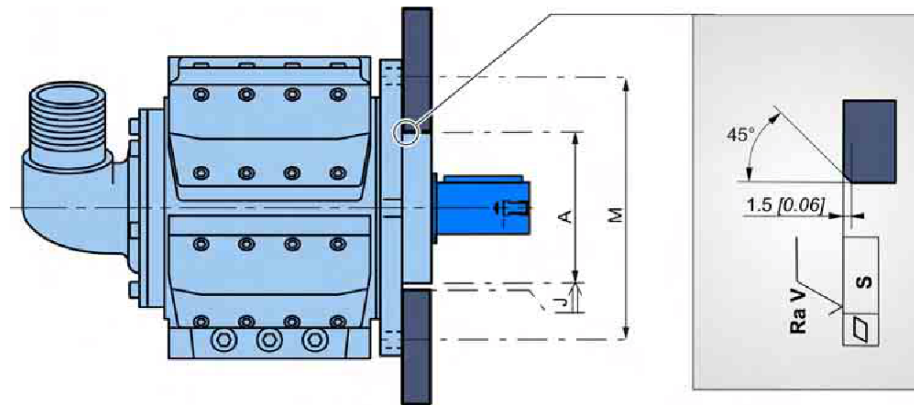

The motor support surfaces must be clean (free of paint, grease, oxidation, etc.) in order for it to be properly mounted on the vehicle.



Unless absolutely flat, the pump chassis fixations may break.

	A	M	J	J	S	Ra V					
	mm [in]	mm [in]	min.	max.					CI 8.8	CI 10.9	CI 12.9
2H14	Ø 140 [5.51 dia]	Ø 180 [7.09 dia]	0.2	0.3	0.2	12.5 µm	2 x M16	210 [155]	295 [218]	355 [262]	
3H14	Ø 140 [5.51 dia]	Ø 180 [7.09 dia]									86 [63]
4H10	Ø 140 [5.51 dia]	Ø 180 [7.09 dia]	[0.008]	[0.012]	[0.008]	[0.492µin]	4 x M12	86 [63]	120 [89]	145 [107]	
4H14	Ø 160 [6.30 dia]	Ø 224 [8.82 dia]									410 [302]
4H18	Ø 224 [8.82 dia]	Ø 280 [11.02 dia]	710 [524]	1 000 [738]	1 200 [885]						
4H20	Ø 280 [11.02 dia]	Ø 355 [13.98 dia]				210 [155]	295 [218]	355 [262]			
6H14	Ø 160 [6.30 dia]	Ø 312 [12.28 dia]	710 [524]	1 000 [738]	1 200 [885]						
6H20	Ø 280 [11.02 dia]	Ø 475 [18.70 dia]									

CIRCUITS

Checking Connections



Piping and Connections

The different components of the hydraulic circuit (tank, pumps, distributors, filters, sinks, etc.) are connected together by rigid piping or flexible hoses.

Two types of connections:



Screwed Connections

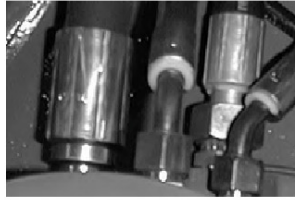

Clamped



Comply with the connection directions given by the manufacturers for each part: function and marking of the ports, types of connections, diameters, types of lines (flexible or rigid), etc.

Rigid Tubes

For high-pressure pipes, only use unwelded cold-drawn steel pipes.

Take the following precautions for making up the tubes:

- After arranging the length by cutting, cold bending and crimping, the tubes must be carefully deburred, rinsed with oil and blown before connection.
- The tubes having been welded or bent also have to be scraped (solution based on sulfuric acid) then rinsed with oil and neutralized (solution based on sodium hydroxide).
- The connections, clamps, threaded plugs, etc. must be deburred and cleaned before assembly.
- If assembly is not done immediately, seal the ports with plugs.



The tubes must not be subject to bending forces while the clamps that attach them are being tightened.



Flexible Tubes

Only use flexible tubes with crimped ends.

Avoid contacts likely to break down the flexible tubes.

As needed protect them with armor.



Observe the minimum radius of curvature..

Avoid kinks..



Connections

Sizing

The drainage of the hydraulic motors' casings must be sized adequately to limit the casing pressure in conformance with the specification's of the manufacturers of these components.



The tube's interior diameter must be greater than or equal to the diameter of the connection openings of the components.

Connection

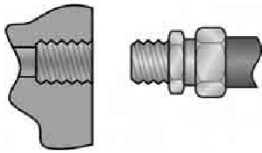

Check the compatibility of the types of connections between the tubes and the motor's ports. If they are not compatible, use intermediate connections that allow bridging this incompatibility.

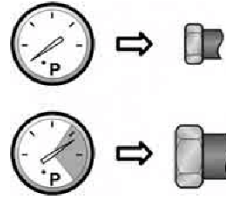

Confirm that the connection class and operating pressure are fully adequate.

Rinsing the Circuit

Before putting the installation to use, perform a complete rinsing of the hydraulic circuit to remove all the impurities that could accumulate while connecting components.

The filters must be equipped with a system that allows checking the filters state (clogging indicator).

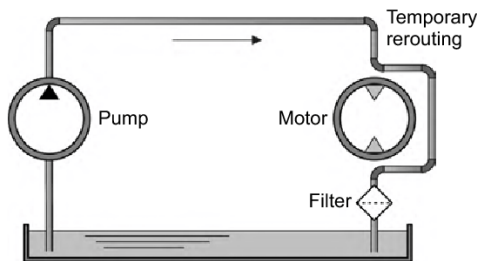

The circuit's return filter can be used to collect these impurities (change the cartridge **SEVERAL** times if necessary) or temporarily interpose before the tank a filter without 10µm absolute bypass appropriate for the return circuit's flow-rate.

- In any case, also place a temporary bypass circuit near the ports of each hydraulic motor to isolate the circuit.
- Change the filter cartridge (open circuit) or temporarily remove the filter before putting into use.

Checking after Rinsing



Check the hydraulic fluid level in the tank and potentially top it off with a filling group.

OILS

Fluid Selection



General Recommendations

Poclair hydraulics recommends the use of hydraulic fluids defined by the ISO 12922 and ISO 6743-4 standards. For temperate climates, the following types are recommended.

- HM 46 or HM 48 for fixed installations.
- HV 46 or HV 68 for mobile installations.
- HEES 46 for mobile installations.

These specifications correspond to category 91H of the CETOP standard, parts 1, 2 and 3 of the DIN 51524 standard, and grades VG32, VG 46 and VG68 of the ISO 6743-4 standards.



It is also possible to use ATF, HD, HFB, HFC or HFD type hydraulic fluid upon Poclair Hydraulics specific approval of the components' operating conditions.



Standardized designations for the fluids

- **HM** : Mineral fluids having specific antioxidant, anticorrosion and antiwear properties (HLP equivalent to DIN 51524 parts 1 and 2).
- **HV** : HM mineral fluids providing improved temperature and viscosity properties (DIN 51524 part 3).
- **HEES** : Biodegradable fluids based on organic esters.



Class 32 (ISO VG 32) : Viscosity of 32 cSt at 40°C.

Class 46 (ISO VG 46) : Viscosity of 46 cSt at 40°C.

Class 68 (ISO VG 68) : Viscosity of 68 cSt at 40°C.



During operation, the oil temperature must remain between 50° and 60°C and under no circumstances should it happen to go over 80°C. The viscosity must always be over 9 cSt, otherwise check the cooling circuit.

Extract of the NF ISO 11 158 Standard

Tests	Test Methods or Standards	HM Category					Units
		Viscosity Grade					
		22	32	46	68	100	
Kinematic viscosity at 40°	ISO 3104	19.8 24.2	28.8 35.2	41.4 50.6	61.2 74.8	90 110	mm ² / s
Minimum viscosity index (a)	ISO 2909	-	-	-	-	-	1
Acidity index, maximum (b)	ISO 6618	(c)	(c)	(c)	(c)	(c)	mg KOH / g
Water context, maximum	ASTM D 1744 DIN 51777-1 DIN 51777-2 (d)	500	500	500	500	500	mg / kg
Flash point Cleveland in open-cup, min.	ISO 2592	140	160	180	180	180	°C
Foaming at 24°C, max. 93°C, max.	ISO 6247	150/0 75/0	150/0 75/0	150/0 75/0	150/0 75/0	150/0 75/0	ml
Deaeration at 50°C, maximum	ISO 9120	5	5	10	13	21	min
Copper blade corrosion at 100°C, 3 h maximum	ISO 2160	2	2	2	2	2	Grading
Anti-rust power, method A	ISO 7120	Pass	Pass	Pass	Pass	Pass	
Anti-wear property, FZG A/8, 3/90, minimum	DIN 51354-2	(e)	10	10	10	10	Deterioration Level
Flow point, maximum	ISO 3016	-18	-15	-12	-12	-12	°C
Aptitude to separate from water: Time needed to obtain 3 ml of emulsion at 54°C, max.	ISO 6614	30	30	30	30		min

Tests	Test Methods or Standards	HV Category					Units
		Viscosity Grade					
		22	32	46	68	100	
Kinematic viscosity at 40°	ISO 3104	19.8 24.2	28.8 35.2	41.4 50.6	61.2 74.8	90 110	mm ² / s
Minimum viscosity index (a)	ISO 2909	130	130	130	130	130	1
Acidity index, maximum (b)	ISO 6618	(c)	(c)	(c)	(c)	(c)	mg KOH / g
Water context, maximum	ASTM D 1744 DIN 51777-1 DIN 51777-2 (d)	500	500	500	500	500	mg / kg
Flash point Cleveland in open-cup, min.	ISO 2592	140	160	180	180	180	°C
Foaming at 24°C, max. 93°C, max.	ISO 6247	150/0 75/0	150/0 75/0	150/0 75/0	150/0 75/0	150/0 75/0	ml
Deaeration at 50°C, maximum	ISO 9120	7	7	12	12	20	
Copper blade corrosion at 100°C, 3 h maximum	ISO 2160	2	2	2	2	2	Grading
Anti-rust power, method A	ISO 7120	Pass	Pass	Pass	Pass	Pass	
Anti-wear property, FZG A/8, 3/90, minimum	DIN 51354-2	(e)	10	10	10	10	Deterioration Level
Flow point, maximum	ISO 3016	-42	-36	-36	-30	-21	°C
Aptitude to separate from water: Time needed to obtain 3 ml of emulsion at 54°C, max.	ISO 6614	(c)	(c)	(c)	(c)	(c)	

- (a) These limits should only be taken into consideration for fluids made from hydrocracked or hydro-isomerized mineral oils.
 (b) Both base fluids and additives contribute to the initial acidity index.
 (c) The behavior criteria or the values of properties must be the subject of negotiation between the supplier and the end user.
 (d) The DIN 51777-2 standard applies in cases where interference caused by certain chemical compounds must be avoided. Free bases, oxidizing or reducing agents, mercaptans, some nitrogenous products or other products that react with iodine interfere.
 (e) Not applicable to ISO 22 viscosity grade.

Extract of the ISO 15 380 Standard

Tests	Test Methods or Standards	HM Category				Units
		Viscosity Grade				
		22	32	46	68	
Kinematic viscosity at 40°	ISO 3104	19.8 24.2	28.8 35.2	41.4 50.6	61.2 74.8	mm ² / s
Minimum viscosity index (a)	ISO 2909	-	-	-	-	
Acidity index, maximum (b)	ISO 6618	(c)	(c)	(c)	(c)	mg KOH / g
Water context, maximum	ASTM D 1744 DIN 51777-1 DIN 51777-2 (d)	1000	1000	1000	1000	mg / kg
Flash point Cleveland in open-cup, min.	ISO 2592	165	175	185	195	°C
Foaming at 24°C, max. 93°C, max.	ISO 6247	150/0 75/0	150/0 75/0	150/0 75/0	150/0 75/0	ml
Deaeration at 50°C, maximum	ISO 9120	7	7	10	10	min
Copper blade corrosion at 100°C, 3 h maximum	ISO 2160	2	2	2	2	Grading
Anti-rust power, method A	ISO 7120	Pass	Pass	Pass	Pass	
Anti-wear property, FZG A/8, 3/90, minimum	DIN 51354-2	(e)	10	10	10	Deterioration Level
Flow point, maximum	ISO 3016	-21	-18	-15	-12	°C
Aptitude to separate from water: Time needed to obtain 3 ml of emulsion at 54°C, max.	ISO 6614	(c)	(c)	(c)	(c)	min

Tests	Test Methods or Standards	HV Category				Units
		Viscosity Grade				
		22	32	46	68	
Kinematic viscosity at 40°	ISO 3104	19.8 24.2	28.8 35.2	41.4 50.6	61.2 74.8	mm ² / s
Minimum viscosity index (a)	ISO 2909	-	-	-	-	1
Acidity index, maximum (b)	ISO 6618	(c)	(c)	(c)	(c)	mg KOH / g
Water context, maximum	ASTM D 1744 DIN 51777-1 DIN 51777-2 (d)	1000	1000	1000	1000	mg / kg
Flash point Cleveland in open-cup, min.	ISO 2592	165	175	185	195	°C
Foaming at 24°C, max. 93°C, max.	ISO 6247	150/0 75/0	150/0 75/0	150/0 75/0	150/0 75/0	ml
Deaeration at 50°C, maximum	ISO 9120	7	7	10	10	min
Copper blade corrosion at 100°C, 3 h maximum	ISO 2160	2	2	2	2	Grading
Anti-rust power, method A	ISO 7120	Pass	Pass	Pass	Pass	
Anti-wear property, FZG A/8, 3/90, minimum	DIN 51354-2	(e)	10	10	10	Deterioration Level
Flow point, maximum	ISO 3016	(c)	(c)	(c)	(c)	°C
Aptitude to separate from water: Time needed to obtain 3 ml of emulsion at 54°C, max.	ISO 6614	(c)	(c)	(c)	(c)	min

- (a) These limits should only be taken into consideration for fluids made from hydrocracked or hydro-isomerized mineral oils.
 (b) Both base fluids and additives contribute to the initial acidity index.
 (c) The behavior criteria or the values of properties must be the subject of negotiation between the supplier and the end user.
 (d) The DIN 51777-2 standard applies in cases where interference caused by certain chemical compounds must be avoided. Free bases, oxidizing or reducing agents, mercaptans, some nitrogenous products or other products that react with iodine interfere.
 (e) Not applicable to ISO 22 viscosity grade.

Temperature and Viscosity

The best performance is obtained by having the system operate in the regimes shaded gray.

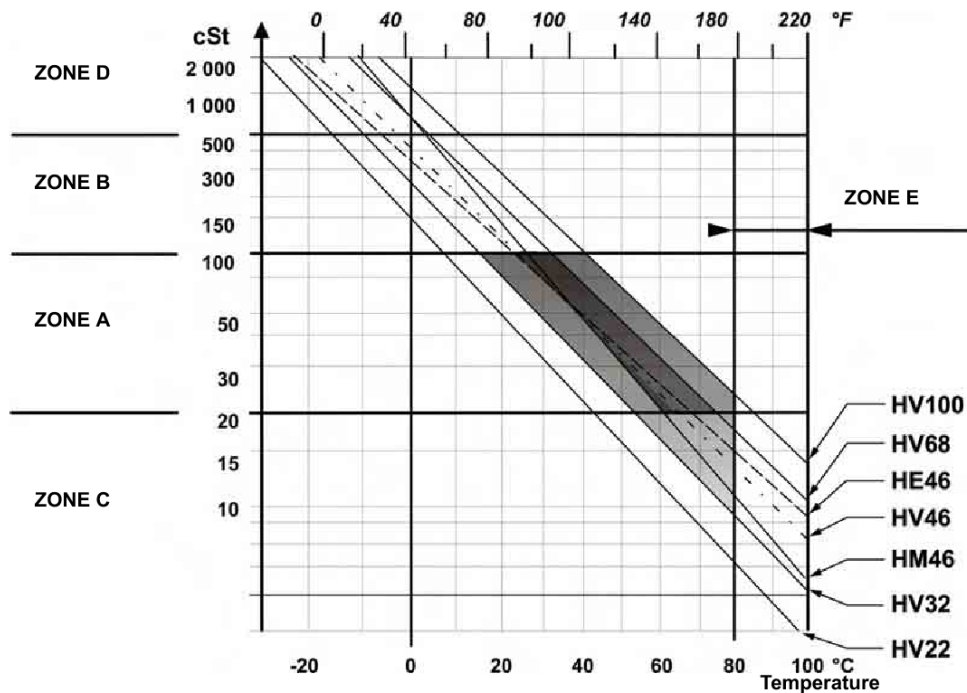

Zone A	<p>Zone of maximum efficiency.</p> <p>In this zone, temperature variations have a weak effect on the response time, efficiency and life expectancy of the components.</p> <p>Poclain Hydraulics components can operate at all speeds, pressures and powers specified in their technical documentation.</p>
Zone B	<p>High speeds can lead to vibrations and drops in mechanical efficiency. The booster pump can cavitate if the intake conditions are too tight but without risk for the system as long as the pump remains boosted.</p> <p>The Poclain Hydraulics components can operate at the pressures specified in their documentation but it is not advisable to use the pumps at full displacement.</p> <p>In a translation circuit, a rapid rise in the pump speed from zone B is allowed, but ordering the translation when the temperature has reached zone A is recommended.</p>
Zone C	<p>The efficiency is less and the use of effective antiwear additives is required.</p> <p>The Poclain hydraulics components can temporarily operate at a power under 20 to 50% of that stated in the technical documentation, or during 20% of the operating time at the stated power.</p>
Zone D	<p>The stated restrictions for zone B likewise apply to zone D.</p> <p>Further, the pumps must startup at low speed and no displacement. They must not be used in their normal operating conditions as long as the booster pressure has not stabilized and the hydraulic fluid temperature in the reservoir has not come up to zone B.</p>
Zone E	<p>The efficiency is reduced and the risk of wear on the pump and hydraulic fluid is increased.</p> <p>The system can operate in zone E at low-pressure and during short periods.</p> <p>The temperature of the hydraulic fluid in the power circuit must not be more than 10°C above the temperature of the hydraulic fluid in the reservoir, and must not be more than 20°C warmer than the hydraulic fluid in the components' cases.</p>

Decontamination and Filtration



The life of hydraulic components is lengthened when the contamination level is low.

Open Circuit

The hydraulic fluid must be maintained at ISO standard 4406 decontamination level 17/15/13 (class 7 from NAS 1638) using a filter.

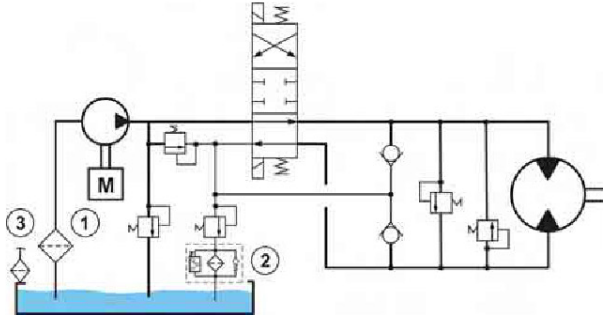

- 1 - A 120 µm strainer on the intake line.
- 2 - A $\beta_{20} > 100$ filter with a clogging indicator on the return line.
- 3 -



Consult manufacturer's instructions for components (filters, pumps, valves, etc.).



The recommended intake filter size is four-time state of the booster pump.

Water Content

The ISO 12922 standard calls for a water content $\leq 0.05\%$.
 Poclain Hydraulics components tolerate up to 0.1%.

Checking Water Content



Visual Inspection

• The oil appears cloudy once it has a water concentration greater than or equal to 1%.

We suggest two possible verification methods:

1- Quick Elementary Check



• The "crackle test."

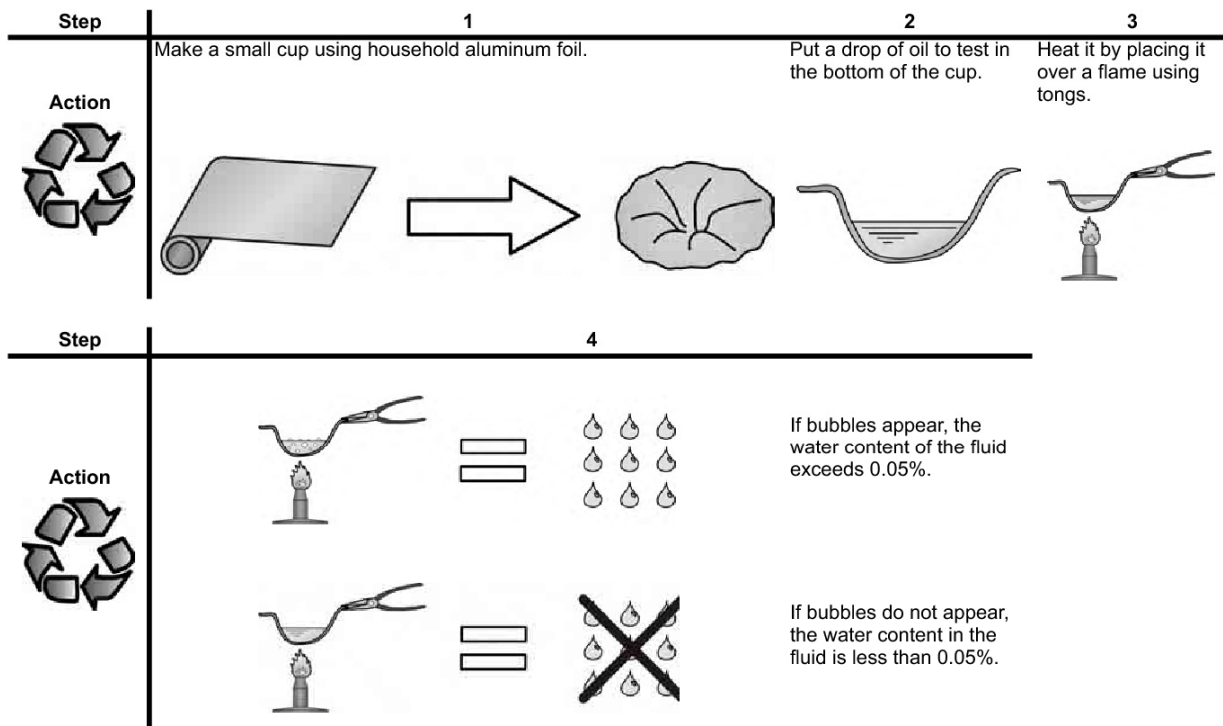

2- Laboratory analysis

To determine the exact water content of the fluid, we recommend a laboratory analysis.



Poclain Hydraulics performs laboratory analyses of water content in fluids. Contact us for further information.

INSTALLATION

Installing the horizontal shaft

The pump should be secured to a rigid support, with the pump shaft in a horizontal position.

The casing has a bleed screw; this should be located in the upper part.

The cylinder heads must be accessible because they enclose the valve assembly (discharge valves).

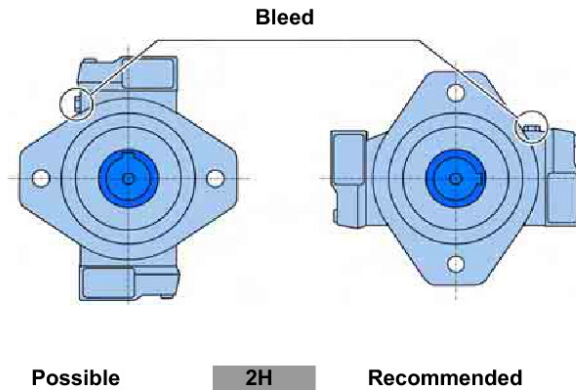

Obligatory installation positions

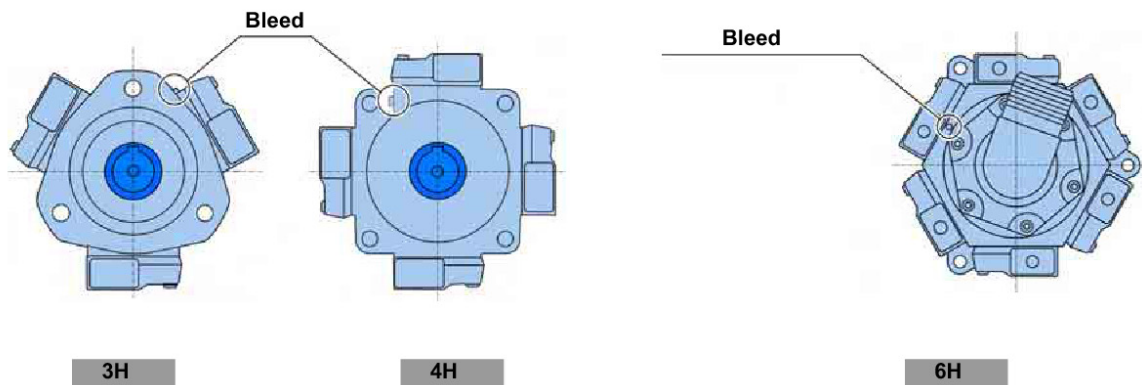

For other mounting possibilities, please consult your Poclairn Hydraulics engineer.

Installing the vertical shaft:

Pump with 1 or 2 bodies

The bleed screw is positioned to allow vertical installation with the shaft pointing upward.



In any other conditions, please consult your Poclairn Hydraulics application engineer.

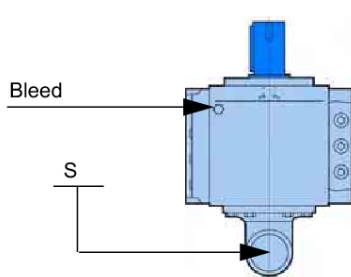

2H

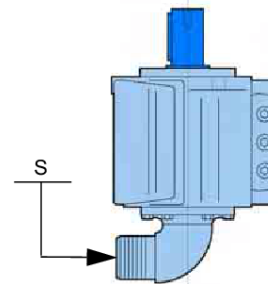

3H

Pumps with 3, 4 or 6 bodies

Vertical installation is possible with the shaft pointing upward or downward, but is not always provided for.



In any other conditions, please consult your Poclairn Hydraulics application engineer.

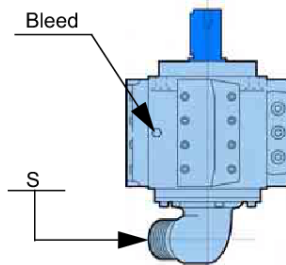

4H

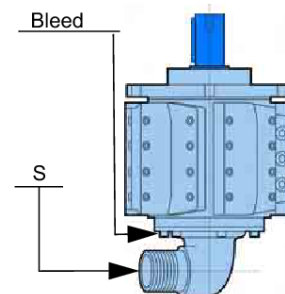

6H

Immersed installation

For immersed installation, the plug that normally blocks the bleed port should be removed, and the port should always be immersed.

Supply pipe orientations

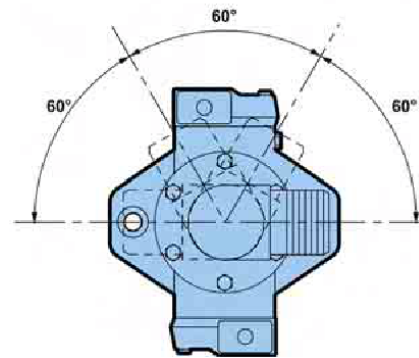
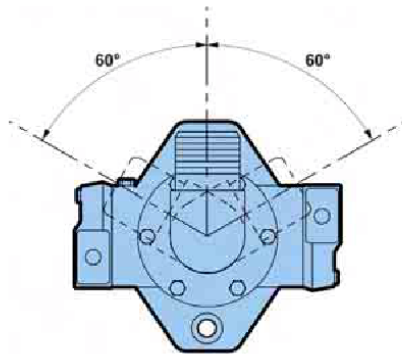

2H

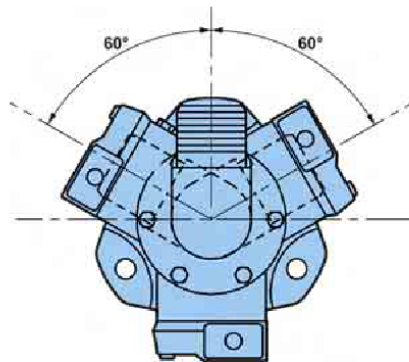

3H

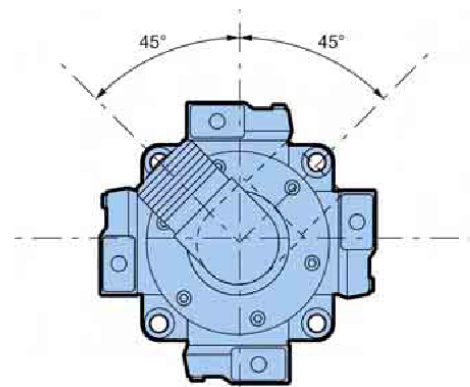

4H

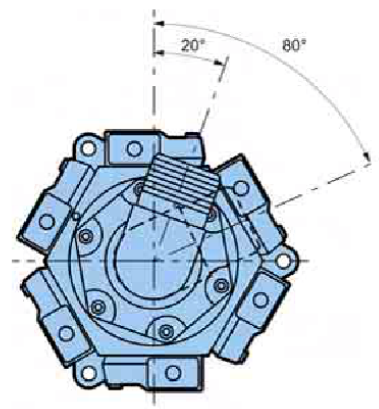

6H

Pipes

Use a reinforced durite pipe at the intake. The intake pipe must be as short and straight as possible and without a high point, to prevent air pockets from becoming trapped in the pipe. At the discharge, we recommend the installation of a flexible hose at the pump outlet.

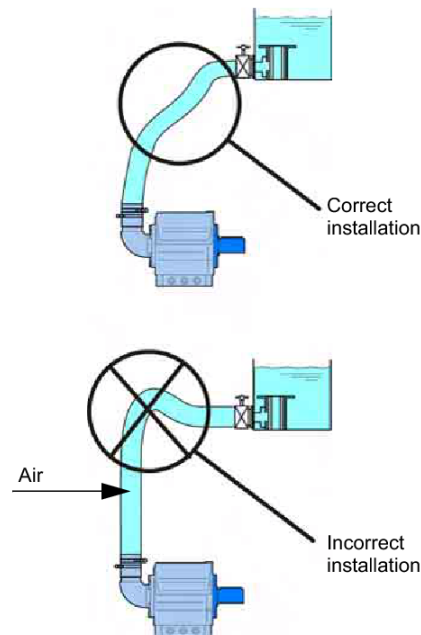

Coupling

The pump shaft coupling can be either of the following types:

- Direct coupling,
- Universal joint coupling in compliance with standard ANSI B92-A (sleeve fitted to the pump shaft).



In any other conditions, please consult your Poclair Hydraulics application engineer.

Drive

.By electric motor or diesel or gas combustion engine.



In any other conditions, please consult your Poclair Hydraulics application engineer.

Hydraulic supply

By observing certain rules about the hydraulic supply, you can favor correct pump operation and pump durability.

Tank, head height

The tank position must ensure the following:

In operation, a pressure of 0.02 to 0.03 bar (*0.29 to 0.44 PSI*) at the pump intake at normal circuit temperature. This temperature depends on operating conditions.

.On start-up, when the oil is cold, the pressure drop must not exceed 0.05 bar (*0.73 PSI*).

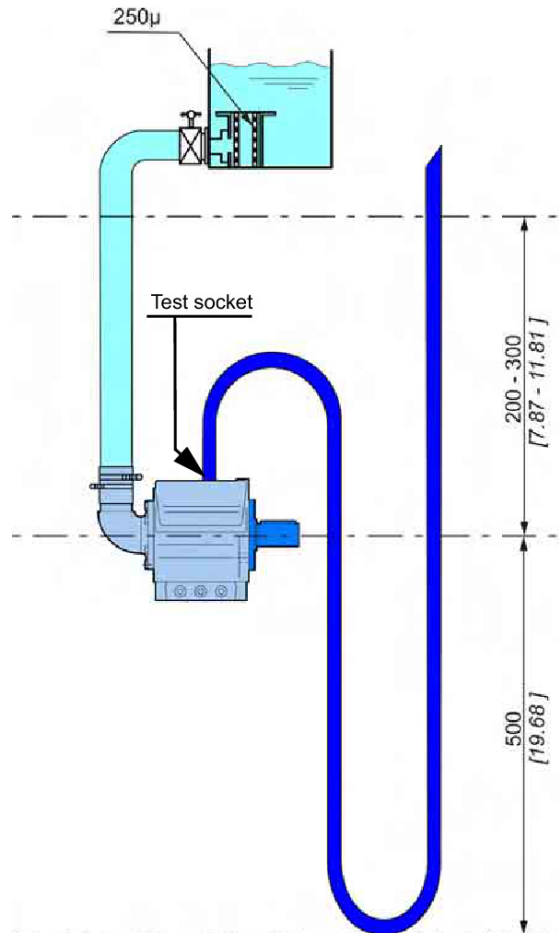

- Normal tank capacity is 1 to 2 times the pump flow per minute.
- The oil returns must be located as far as possible from the intake and must be immersed in oil.
- When filling, ensure that the tank is perfectly clean.

PUTTING IN SERVICE



It is extremely important to follow this procedure along with the specific instructions provided by the manufacturer of each component during the startup of a new or reconditioned system.

Before putting into service:

- Check connections (cable/hose clamps, flange connections, etc.).
- Fill the tank.
- Open the suction valve.
- Bleed the pump casing (re-tighten the screw when the jet of oil comes out regularly, without air bubbles).
- Check that the pressure at the pump intake is above the required operating value. This pressure should be measured at the intake elbow joint.
- Check that the directional valves, valves, etc. are positioned so that the pump flows off-load or at minimum pressure (put the valves out of adjustment).

Putting the pump in service

Driven by an electric motor

- Using electrical pulses, ensure that the motor drives the pump's rotation in the direction shown by the arrow on the cylinder heads.
- Continue applying electrical pulses to prime the pump (automatic priming).
- If no abnormal noise is heard after about ten pulses, start the electric motor.
- Run the pump off-load for a few minutes. If the pump is properly primed, no vibration should be detected in the discharge hoses.
- Check the oil level in the tank, and top up if necessary.
- Check the suction pressure.
- Next, begin loading the pump: supply the actuators, adjust the valves, etc. (refer to installation manual for component(s)).

Driven by a combustion engine

- Use the starter to run the motor, and ensure that it rotates in the correct direction.
- Start the combustion engine and allow it to idle to prime the pump.
- If the pump is properly primed, no vibration should be detected in the discharge hoses.
- Check the hydraulic fluid level in the tank, and top up if necessary.
- Gradually increase the engine speed to top speed.
- Check the suction pressure, return the combustion engine to its normal operating speed, and load the pump.



Poor priming can cause poor pump operation and can quickly destroy the pump.



For the sake of safety, the casing should be purged again after a few minutes of operation.

- Check the pump operating conditions: maximum speed, pressure, and temperature.