



P90 PUMPS



P90 – 250. HYDRAULIC PUMPS.

Design

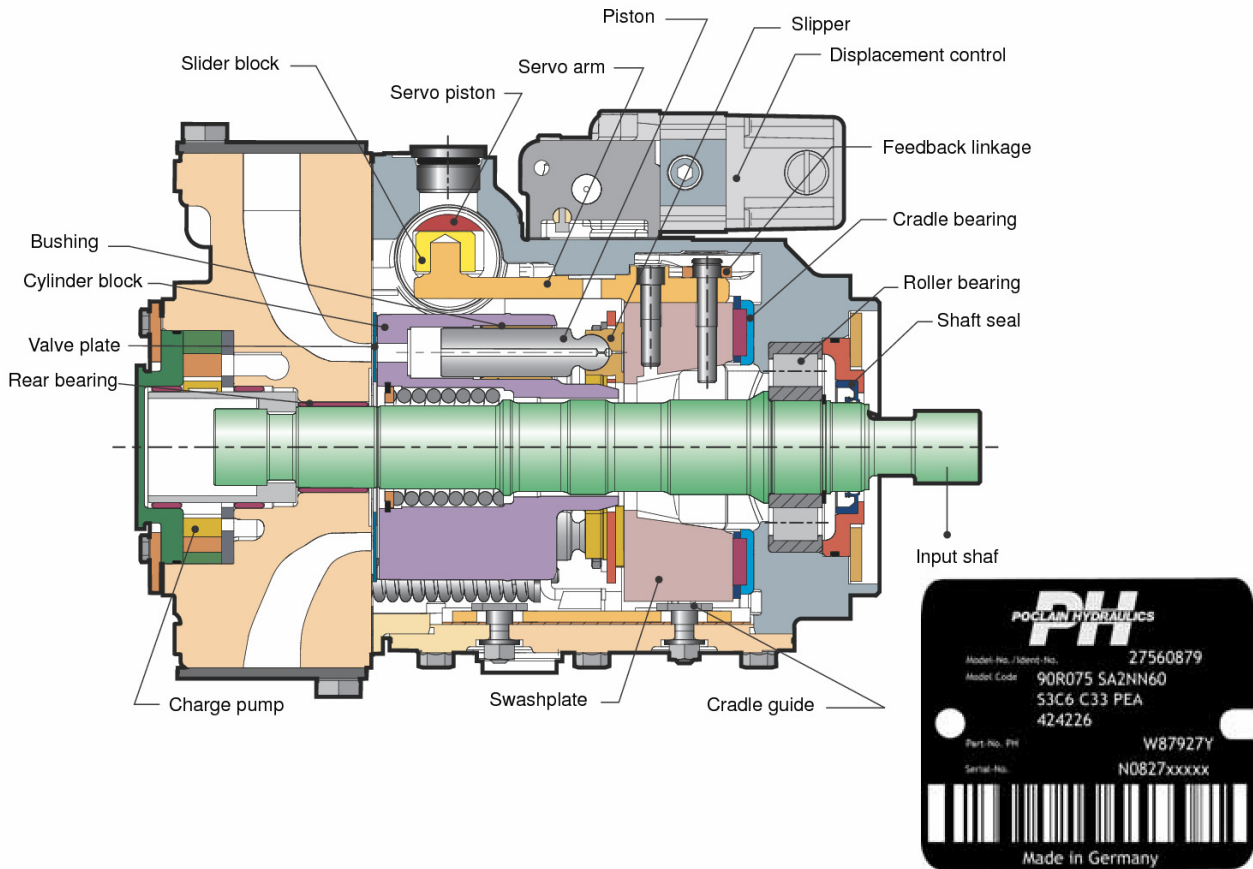

Features and options	Unit	Frame					
		055	075	100	130	180	250
Displacement	cm ³ /rev [in ³ /rev.]	55 [3.35]	75 [4.58]	100 [6.10]	130 [7.91]	180 [10.98]	250 [15.25]
Flow at rated speed	L/min [US gal/min]	215 [57]	270 [71]	330 [87]	403 [106]	468 [124]	575 [152]
Torque at maximum displacement	N.m/bar [lbf.in/1000 PSI]	0.88 [530]	1.19 [730]	1.59 [970]	2.07 [1 260]	2.87 [1 750]	3.97 [2 433]
Mass moment of inertia of rotating component	kg.m ² [slug.ft ²]	0.0060 [0.0044]	0.0096 [0.0071]	0.0150 [0.0111]	0.0230 [0.0170]	0.0380 [0.0280]	0.0650 [0.0479]
Weight	kg [lb]	40 [88]	49 [108]	68 [150]	88 [194]	136 [300]	154 [340]
Mounting (per SAE J744)		C	C	C	D	E	E
Rotation		Clockwise or Counterclockwise					
Main ports: 4-bolt split-flange (per SAE J518 code 62)	mm [in]	25.4 [1.0]	25.4 [1.0]	25.4 [1.0]	31.75 [1.25]	38.1 [1.5]	38.1 [1.5]
Main port configuration		Radial or axial			Radial		
Case drain ports (SAE O-ring boss)	UNF thread (in.)	1.0625–12	1.0625–12	1.0625–12	1.625–12	1.625–12	1.625–12
Other ports		SAE O-ring boss.					
Shafts		Splined, straight keyed, and tapered shafts available.					
Auxiliary mounting SAE		SAE A, B, C		SAE A, B, C, D		SAE A, B, C, D, E	
Installation position		Installation is recommended with control on the top or side. Consult your representative for nonconformance guidelines. The housing must remain filled with hydraulic fluid.					



CONTENT

MODEL CODE	4	Model Code
OPERATING PARAMETERS	9	Operating Parameters
SYSTEM DESIGN PARAMETERS	13	System design Para.
INSTALLATION DRAWINGS	17	Installation Drawings
FRAME SIZE 055	19	SIZE 055
FRAME SIZE 075	23	SIZE 075
FRAME SIZE 100	27	SIZE 100
FRAME SIZE 130	29	SIZE 130
FRAME SIZE 180	33	SIZE 180
FRAME SIZE 250	37	SIZE 250
OPTIONS	43	Options

MODEL CODE

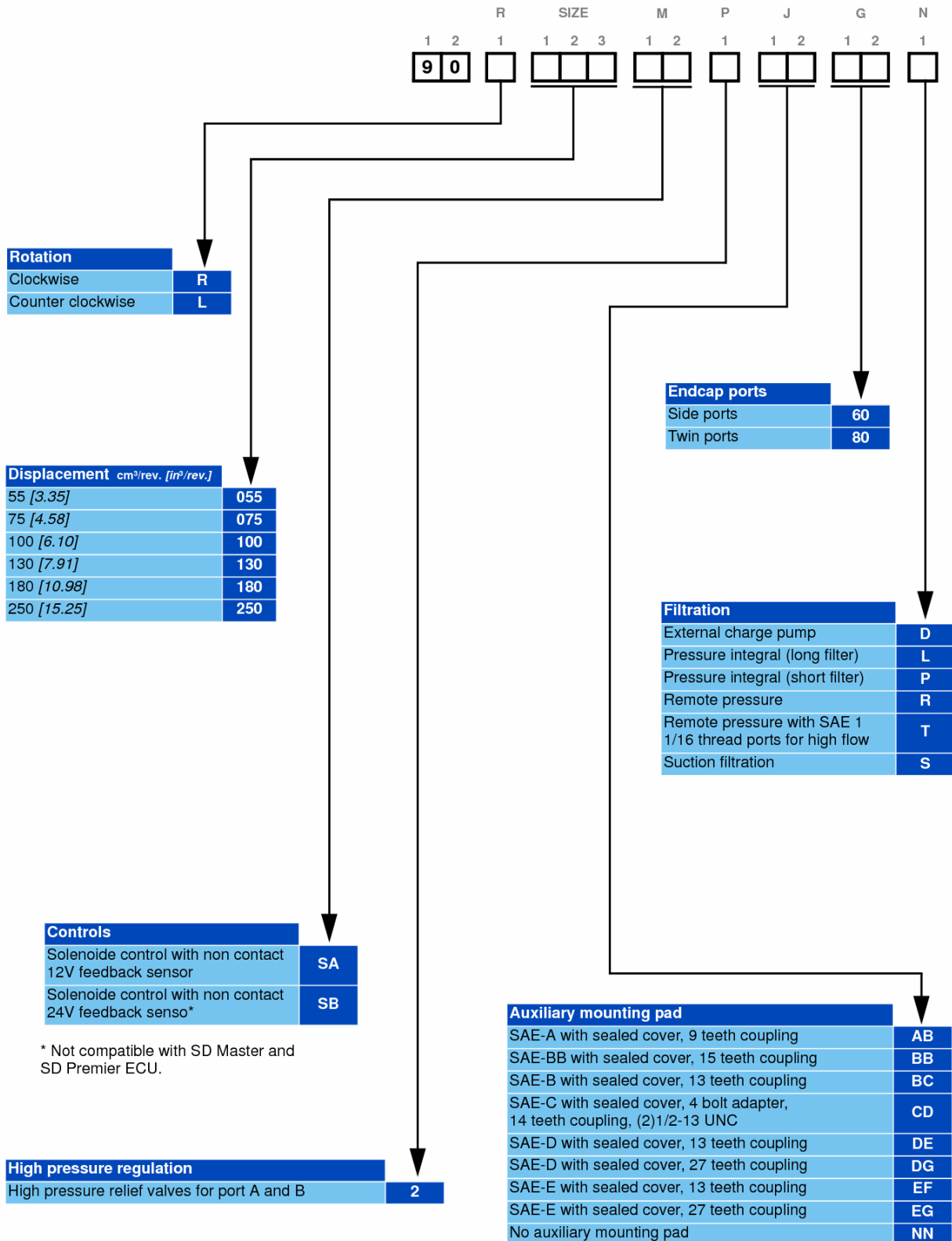

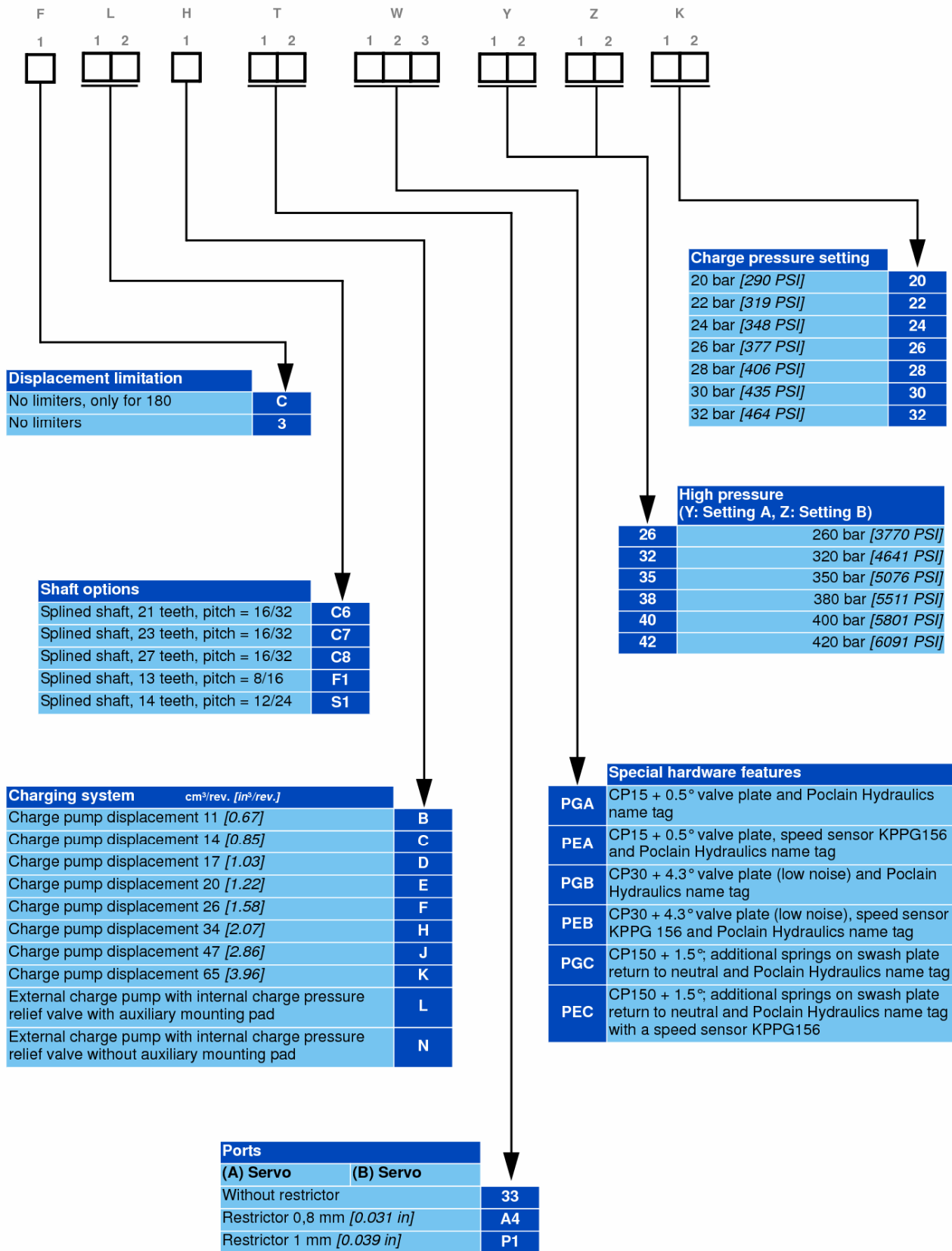

Possible configurations

● Standard - Not available

		Rotation (R1)					
Option	Description	055	075	100	130	180	250
R	Clockwise	●	●	●	●	●	●
L	Counter clockwise	●	●	●	●	●	●

		Controls (M)					
Option	Description	055	075	100	130	180	250
SA	Solenoid control 12V with non contact feedback sensor	●	●	●	●	●	●
SB	Solenoid control 24V with non contact feedback sensor	●	●	●	●	●	●

		High pressure regulation (P)					
Option	Description	055	075	100	130	180	250
2	High pressure relief valves for port A and B	●	●	●	●	●	●

		Auxiliary mounting pad (J)					
Option	Description	055	075	100	130	180	250
AB	SAE-A with sealed cover, 9 teeth coupling	●	●	●	●	●	●
BB	SAE-BB with sealed cover, 15 teeth coupling	●	●	●	●	●	●
BC	SAE-B with sealed cover, 13 teeth coupling	●	●	●	●	●	●
CD	SAE-C with sealed cover, 4 bolt adapter, 14 teeth coupling, (2)1/2-13 UNC	●	●	●	●	●	●
DE	SAE-D with sealed cover, 13 teeth coupling	-	-	-	●	●	●
DG	SAE-D with sealed cover, 27 teeth coupling	-	-	-	●	●	●
EF	SAE-E with sealed cover, 13 teeth coupling	-	-	-	-	●	●
EG	SAE-E with sealed cover, 27 teeth coupling	-	-	-	-	●	●
NN	No auxiliary mounting pad	●	●	●	●	●	●

		Endcap ports (G)					
Option	Description	055	075	100	130	180	250
60	Side ports	●	●	●	-	-	-
80	Twin ports	●	●	●	●	●	●

		Filtration (N)					
Option	Description	055	075	100	130	180	250
D	External charge pump	●	●	●	●	●	-
L	Pressure integral (long filter)	●	●	●	●	-	-
P	Pressure integral (short filter)	●	●	●	●	-	-
R	Remote pressure	●	●	●	●	-	-
T	Remote pressure with SAE 1 1/16 thread ports for high flow	-	-	-	-	●	●
S	Suction filtration	●	●	●	●	●	●

		Displacement limitation (F)					
Option	Description	055	075	100	130	180	250
C	No limiters, only for 180	-	-	-	-	●	-
3	No limiters	●	●	●	●	-	●

		Shaft options					
Option	Description	055	075	100	130	180	250
C6	Splined shaft, 21 teeth, pitch = 16/32	●	●	●	-	-	-
C7	Splined shaft, 23 teeth, pitch = 16/32	-	●	●	-	-	-
C8	Splined shaft, 27 teeth, pitch = 16/32 Splined shaft, 27 teeth, pitch = 16/32	-	-	-	●	●	●
F1	Splined shaft, 13 teeth, pitch = 8/16 Splined shaft, 13 teeth, pitch = 8/16	-	-	●	●	●	●
S1	Splined shaft, 14 teeth, pitch = 12/24	●	●	●	-	-	-

● Standard - Not available

Charging system (H)								
Option	Description	cm ³ /rev. [in ³ /rev.]	055	075	100	130	180	250
B	Charge pump displacement 11 [0.67]		●	-	-	-	-	-
C	Charge pump displacement 14 [0.85]		●	●	-	-	-	-
D	Charge pump displacement 17 [1.03]		●	●	●	-	-	-
E	Charge pump displacement 20 [1.22]		-	●	●	-	-	-
F	Charge pump displacement 26 [1.58]		-	-	●	●	-	-
H	Charge pump displacement 34 [2.07]		-	-	-	●	●	-
J	Charge pump displacement 47 [2.86]		-	-	-	-	●	●
K	Charge pump displacement 65 [3.96]		-	-	-	-	-	●
L	External charge pump with internal charge pressure relief valve		●	●	●	●	●	-
N	External charge pump with internal charge pressure relief valve for units with no auxiliary mounting pad		●	-	●	●	●	-

Restrictors (T)								
Option	Ports		055	075	100	130	180	250
	(A) servo	(B) servo						
33	Without restrictors		●	●	●	●	●	●
A4	Restrictor 0,8 mm [0.031 in]		●	●	●	●	●	●
P1	Restrictor 1 mm [0.039 in]		●	●	●	●	●	●

Special hardware features (W)								
Option	Description		055	075	100	130	180	250
PGA	CP15 + 0,5° valve plate and Poclairn Hydraulics name tag		●	●	●	●		
PEA	CP15 + 0,5° valve plate and Poclairn Hydraulics name tag with a speed sensor KPPG156		●	●	●	●		
PGB	CP30 + 4,3° and Poclairn Hydraulics name tag (Low noise)		●	●	●	●	●	●
PEB	CP30 + 4,3° and Poclairn Hydraulics name tag with speed sensor KPPG 156 (Low noise)		●	●	●	●	●	●
PGC	CP150 + 1.5°; additional springs on swash plate return to neutral and Poclairn Hydraulics name tag						●	●
PEC	CP150 + 1.5°; additional springs on swash plate return to neutral and Poclairn Hydraulics name tag with a speed sensor KPPG156						●	●

High pressure (Y: setting A; Z: setting B)								
Option	Description		055	075	100	130	180	250
26	260 bar		●	●	●	●	●	●
32	320 bar		●	●	●	●	●	●
35	350 bar		●	●	●	●	●	●
38	380 bar		●	●	●	●	●	●
40	400 bar		●	●	●	●	●	●
42	420 bar		●	●	●	●	●	●

Charge pressure setting (K)								
Option	Description		055	075	100	130	180	250
20	20 bar		●	●	●	●	●	●
22	22 bar		●	●	●	●	●	●
24	24 bar		●	●	●	●	●	●
26	26 bar		●	●	●	●	●	●
28	28 bar		●	●	●	●	●	●
30	30 bar		●	●	●	●	●	●
32	32 bar		●	●	●	●	●	●

Methodology :

This document is intended for manufacturers of machines that incorporate Poclairn Hydraulics products. It describes the technical characteristics of Poclairn Hydraulics products and specifies installation conditions that will ensure optimum operation. This document includes important comments concerning safety. They are indicated in the following way:



Safety comment.

This document also includes essential operating instructions for the product and general information. These are indicated in the following way:



Essential instructions.



General information .



Information on the model code.



Weight of component without oil.



Volume of oil.



Units.



Tightening torque.



Screws.



Information intended for Poclairn-Hydraulics personnel.

The views in this document are created using metric standards.

The dimensional data is given in mm and in inches (inches are between brackets and italic)



OPERATING PARAMETERS

Operating parameters	Unit	Frame size					
		055	075	100	130	180	250
Input speed							
Minimum		500					
Continuous	min ⁻¹ (rpm)	3900	3600	3300	3100	2600	2300
Maximum		4250	3950	3650	3400	2850	2500
System pressure							
Rated		420 [6000]					
Maximum	bar [PSI]	480 [7000]					
Minimum low loop		10 [145]					
Inlet pressure (charge inlet)							
Minimum (continuous)	bar (abs.) [in. Hg vac.]	0.7 [9]					
Minimum (cold start)		0.2 [24]					
Case pressure							
Continuous	bar [PSI]	3 [43]					
Maximum (cold start)		5 [73]					

Overviews

Maintain operating parameters within prescribed limits during all operating conditions. This section defines operating limits given in the table *Operating parameters*.

Input speed

Minimum speed is the lowest input speed recommended during engine idle condition. Operating below minimum speed limits the pump's ability to maintain adequate flow for lubrication and power transmission.

Continuous speed is the highest input speed recommended at full power condition. Operating at or below this speed should yield satisfactory product life.

Maximum speed is the highest operating speed permitted. Exceeding maximum speed reduces product life and can cause loss of hydrostatic power and braking capacity. Never exceed the maximum speed limit under any operating conditions.



Exceeding maximum speed may cause a loss of hydrostatic drive line power and braking capacity. You must provide a braking system, redundant to the hydrostatic transmission, sufficient to stop and hold the vehicle or machine in the event of hydrostatic drive power loss.

System pressure

System pressure is the differential pressure between system ports A and B. It is the dominant operating variable affecting hydraulic unit life. High system pressure, which results from high load, reduces expected life. System pressure must remain at or below continuous pressure during normal operation to achieve expected life.

Continuous pressure is the average, regularly occurring operating pressure. Operating at or below this pressure should yield satisfactory product life.

Maximum pressure is the highest intermittent pressure allowed. Maximum machine load should never exceed this pressure. For all applications, the load should move below this pressure.



All pressure limits are differential pressures referenced to low loop (charge) pressure. Subtract low loop pressure from gauge readings to compute the differential.

Case pressure

Under normal operating conditions, the maximum continuous case pressure must not exceed 3 bar [44 PSI]. Maximum allowable intermittent case pressure during cold start must not exceed 5 bar [73 PSI]. Size drain plumbing accordingly.



Operation with case pressure in excess of these limits may damage seals, gaskets, and/or housings, causing external leakage. Performance may also be affected since charge and system pressure are additive to case pressure.

Fluid specifications		
Viscosity	Unit	
Minimum		7 [49]
Continuous	mm ² /sec (cSt) [SUS]	12-80 [70-370]
Maximum		1600 [7500]
Temperature	Unit	
Minimum		-40 [-40]
Continuous	°C [°F]	104 [220]
Maximum		115 [240]
Filtration		
Cleanliness		18/13 or better per ISO 4406
Efficiency (suction filtration)		$\beta_{35-45}=75$ ($\beta_{10} \geq 2$)
Efficiency (charge filtration)		$\beta_{15-20}=75$ ($\beta_{10} \geq 10$)
Recommended inlet screen size		100-125 μm [0.0039-0.0049 in]

Hydraulic Fluids

General Recommendations

Poclair hydraulics recommends the use of hydraulic fluids defined by the ISO 12380 and ISO 6743-4 standards. For temperate climates, the following types are recommended.

- HM 46 or HM 48 for fixed installations.
- HV 46 or HV 68 for mobile installations.
- HEES 46 for mobile installations.



These specifications correspond to category 91H of the CETOP standard, parts 1, 2 and 3 of the DIN 51524 standard, and grades VG32, VG 46 and VG68 of the ISO 6743-4 standards.



It is also possible to use ATF, HD, HFB, HFC or HFD type hydraulic fluid upon Poclair Hydraulics specific approval of the components' operating conditions.

Standardized designations for the fluids

- **HM** : Mineral fluids having specific antioxidant, anticorrosion and antiwear properties (HLP equivalent to DIN 51524 parts 1 and 2).
- **HV** : HM mineral fluids providing improved temperature and viscosity properties (DIN 51524 part 3).
- **HEES** : Biodegradable fluids based on organic esters.

It is also possible to use a fluid that meets the biodegradability criteria and is compatible in the event of accidental food contact. The BIOHYDRAN FG 46 fluid designed by the company Total has undergone testing of its properties and performance on our test benches. Since this type of fluid has not yet been categorized, it is the responsibility of machine manufacturers to validate its compatibility with all of the components used in order to guarantee that the intended functions will be fulfilled (specifically the brakes' hold on a slope and emergency braking) and this for the desired life time of all equipment items.



For biodegradable fluids, consult your Poclair Hydraulics' application engineer



Class32 (ISO VG 32) : Viscosity of 32 cSt at 40 °C.
Class46 (ISO VG 46) : Viscosity of 46 cSt at 40 °C.
Class68 (ISO VG 68) : Viscosity of 68 cSt at 40 °C.



During operation, the temperature of the motors must be between 0 °C [32 °F] and 80 °C [176 °F]; the minimum and maximum temperatures may be exceeded momentarily by ± 20 °C [± 68 °F] for a duration of less than 30 minutes.

For all applications outside these limits, please consult with your Poclair Hydraulics' application engineer.

Efficiency

Pump performance as a function of operating speed

The figure below shows typical overall and volumetric efficiencies for P90 pumps with system pressures of 210 and 420 bar [3000 and 6000 PSI], speed as percent of rated speed, and a fluid viscosity of 8 mm²/s (cSt) [50 SUS].

Rendement global et rendement volumétrique à la cylindrée maximale Overall efficiency (η_t) and volumetric efficiency (η_v) at maximum displacement

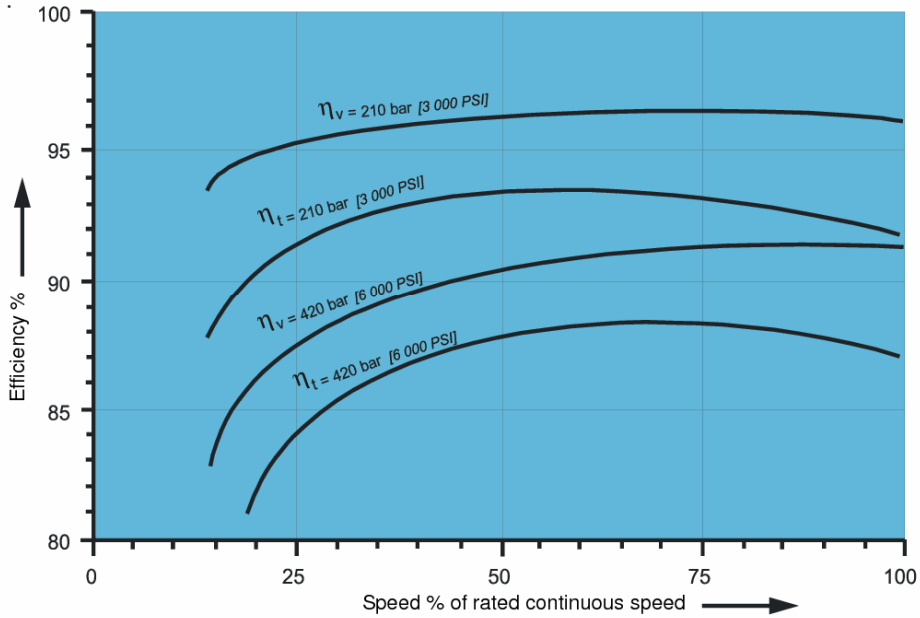

Pump performance as a function of pressure and speed

The following performance maps show typical overall efficiencies for P90 pumps with system pressures from 70 to 420 bar [1 000 to 6 000 PSI] at 2/3 of rated speed varying between 1/4 to maximum displacement. These efficiency maps apply to all frame sizes.

Overall efficiency at maximum displacement

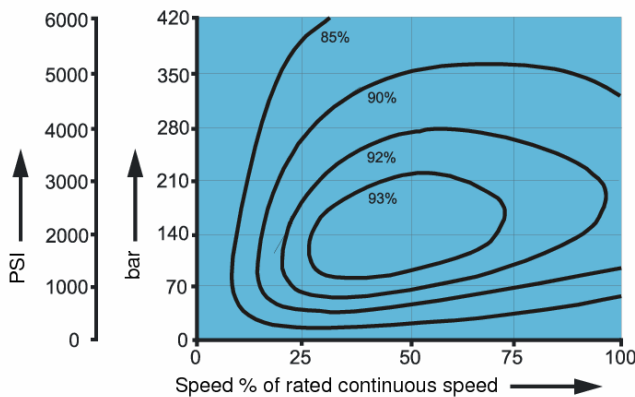

Pump overall (η_t) efficiency at 2/3 rated speed

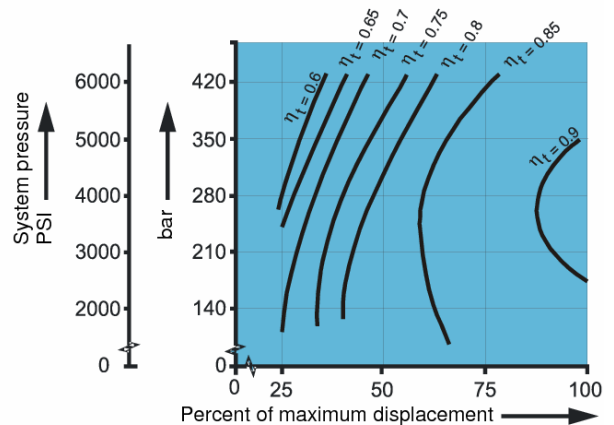

SYSTEM DESIGN PARAMETERS

Fluid and filtration

To prevent premature wear, it is imperative that only clean fluid enter the hydrostatic transmission circuit. A filter capable of controlling the fluid cleanliness to ISO 4406 class 22/18/13 (SAE J1165) or better under normal operating conditions is recommended.

The filter may be located either on the inlet (suction filtration) or discharge (charge pressure filtration) side of the charge pump. The selection of a filter depends on a number of factors including the contaminant ingress rate, the generation of contaminants in the system, the required fluid cleanliness, and the desired maintenance interval. Filters are selected to meet the above requirements using rating parameters of efficiency and capacity.

Filter efficiency may be measured with a Beta ratio¹ (β_x). For simple suction-filtered closed circuit transmissions and open circuit transmissions with return line filtration, a filter with a β -ratio within the range of $\beta_{35-45} = 75$ ($\beta_{10} \geq 2$) or better has been found to be satisfactory. For some open circuit systems, and closed circuits with cylinders being supplied from the same reservoir, a considerably higher filter efficiency is recommended. This also applies to systems with gears or clutches using a common reservoir. For these systems, a charge pressure or return filtration system with a filter β -ratio in the range of $\beta_{15-20} = 75$ ($\beta_{10} \geq 10$) or better is typically required.

Because each system is unique, only a thorough testing and evaluation program can fully validate the filtration system.

Charge pressure

The charge pressure setting listed in the model code is based on the charge flow across the charge pressure relief valve at fluid temperature of 50 °C [120 °F].

Independent braking system



The loss of hydrostatic drive line power, in any mode of operation (forward, neutral, or reverse) may cause the system to lose hydrostatic braking capacity. You must provide a braking system, redundant to the hydrostatic transmission, sufficient to stop and hold the vehicle or machine in the event of hydrostatic drive power loss.

Reservoir

The reservoir should be designed to accommodate maximum volume changes during all system operating modes and to promote de-aeration of the fluid as it passes through the tank.

A suggested minimum total reservoir volume is 5/8 of the maximum charge pump flow per minute with a minimum fluid volume equal to 1/2 of the maximum charge pump flow per minute. This allows 30 seconds fluid dwell for removing entrained air at the maximum return flow. This is usually adequate to allow for a closed reservoir (no breather) in most applications.

Locate the reservoir outlet (charge pump inlet) above the bottom of the reservoir to take advantage of gravity separation and prevent large foreign particles from entering the charge inlet line. A 125 μm screen over the outlet port is recommended. Position the reservoir inlet (fluid return) to discharge below the normal fluid level, toward the interior of the tank. A baffle (or baffles) will further promote de-aeration and reduce surging of the fluid.

¹ Filter β_x -ratio is a measure of filter efficiency defined by ISO 4572. It is defined as the ratio of the number of particles greater than a given diameter ("x" in microns) upstream of the filter to the number of these particles.

Case drain

A case drain line must be connected to one of the case outlets (L1 or L2) to return internal leakage to the system reservoir. The higher of the two case outlets should be used to promote complete filling of the case. Since case drain fluid is typically the hottest fluid in the system, it is advantageous to return this flow through the heat exchanger.

Sizing equations

The following equations are helpful when sizing hydraulic pumps. Generally, the sizing process is initiated by an evaluation of the machine system to determine the required motor speed and torque to perform the necessary work function. First, the motor is sized to transmit the maximum required torque. The pump is then selected as a flow source to achieve the maximum motor speed.

SI units			
Output flow Q	$= \frac{V_g \cdot n \cdot \eta_v}{1000}$	(l/min)	$V_g =$ Displacement per revolution (cm ³ /tr)
Input torque M	$= \frac{V_g \cdot \Delta p}{20 \cdot \pi \cdot \eta_m}$	(N.m)	$\Delta p =$ p _o - p _i (system pressure) (bar)
Input power P	$= \frac{M \cdot n \cdot \pi}{30\,000} = \frac{Q \cdot \Delta p}{600 \cdot \eta_t}$	(kW)	n = Speed (tr/mn) $\eta_v =$ Volumetric efficiency $\eta_m =$ Mechanical efficiency $\eta_t =$ Overall efficiency ($\eta_v \cdot \eta_m$)

US units			
Output flow Q	$= \frac{V_g \cdot n \cdot \eta_v}{231}$	(US gal/min)	$V_g =$ Displacement per revolution (in ³ /rev)
Input torque M	$= \frac{V_g \cdot \Delta p}{2 \cdot \pi \cdot \eta_m}$	(lbf.in)	$\Delta p =$ p _o - p _i (system pressure) (bar)
Input power P	$= \frac{M \cdot n \cdot \pi}{198\,000} = \frac{Q \cdot \Delta p}{1714 \cdot \eta_t}$	(hp)	n = Speed (rpm) $\eta_v =$ Volumetric efficiency $\eta_m =$ Mechanical efficiency $\eta_t =$ Overall efficiency ($\eta_v \cdot \eta_m$)

Shaft Loads

Normal bearing life in B_{10} hours is shown in the table below. The figures reflect a continuous differential pressure of 240 bar [3500 PSI], 1800 min^{-1} (rpm) shaft speed, maximum displacement, and no external shaft side load. The data is based on a 50% forward, 50% reverse duty cycle, standard charge pump size, and standard charge pressure.

P90 pumps are designed with bearings that can accept external radial and thrust loads. The external radial shaft load limits are a function of the load position and orientation, and the operating conditions of the unit.

The maximum allowable radial load (Re), is based on the maximum external moment (Me), and the distance (L) from the mounting flange to the load. It may be determined using the table and formula below. Thrust (axial) load limits are also shown.

$$Re = Me / L$$

All external shaft loads affect bearing life. In applications with external shaft loads, minimize the impact by positioning the load at 90° or 270° as shown in the figure.

Contact your Poclain Hydraulics representative for an evaluation of unit bearing life if:

- continuously applied external loads exceed 25 % of the maximum allowable radial load (Re).
- the pump swashplate is positioned on one side of center all or most of the time.
- the unit bearing life (B_{10}) is critical.

Bearing life	
Frame size	Bearing life – B_{10} hrs
055	22 090
075	22 970
100	22 670
130	17 990
180	16 150
250	12 020

Radial and thrust load position

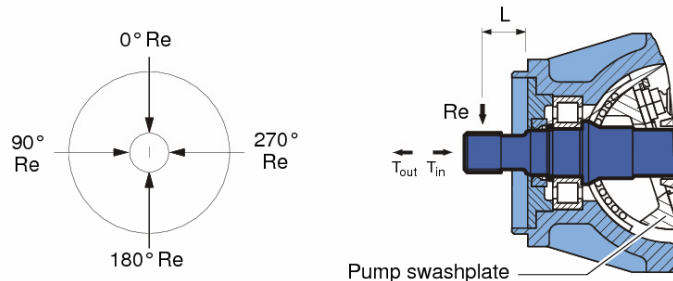

Parameter	Allowable external shaft load					
	Frame size					
	055	075	100	130	180	250
External moment (Me) N.m [lbf.in]	101 [893]	118 [1044]	126 [1115]	140 [1239]	161 [1425]	176 [1557]
Maximum shaft thrust in (T_{in}) N [lbf]	3340 [750]	4300 [966]	5160 [1160]	5270 [1184]	7000 [1573]	7826 [1759]
Maximum shaft thrust out (T_{out}) N [lbf]	910 [204]	930 [209]	1000 [224]	688 [154]	1180 [265]	1693 [380]

INSTALLATION DRAWINGS

Pump

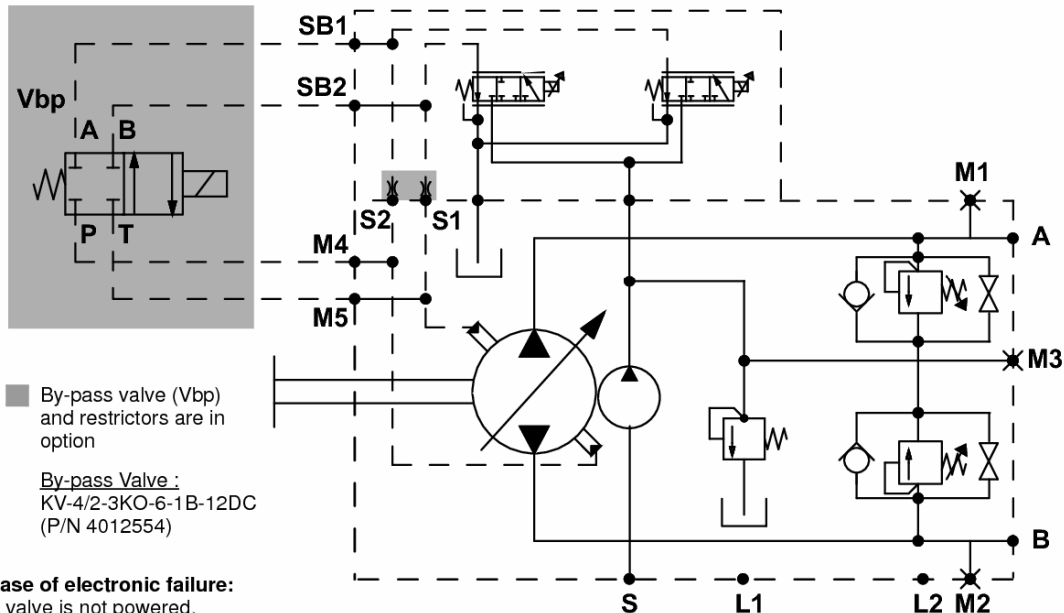

In case of electronic failure:
The valve is not powered.

The pump is able to return to its neutral position slowly to avoid machine jerk.

During normal operating or shifting:
The valve is powered.

The pump has a very short response time to allow soft shifting of Poclairn Hydraulics motors.

Orifices are by passed to bring maximum flow directly to the servo cylinders.

- A et B : Main system of the loop (input / output)
- S : charge (feed) inlet
- L1 and L2 : case drain
- M1 and M2 : A and B ports pressure gauge
- M3 : charge (feed) pressure gauge
- M4 and M5 : control pressure gauge

Ports size						
Ports	Frame size					
	055	075	100	130	180	250
A and B	1" flange SAE J518 code 62		1"-1/4 flange SAE J518 code 62		1"-1/2 flange SAE J518 code 62	
S	1-5/16 - 12 UN 2B		1-5/8 - 12 UN 2B			1"-1/2 flange SAE J518 code 61
L1 and L2	1"-1/16 - 12 UN 2B		1"-5/16 - 12 UN 2B		1"-5/8 - 12 UN 2B	
M1, M2 and M3	9/16" - 18 UNF 2B					
M4 and M5	7/16" - 20 UNF 2B		9/16" - 18 UNF 2B			



SA or SB control

Features :

- Proportional electronic control driven by the Poclairn Hydraulics electronic boxes.
- Our electronic control boxes control the displacement and the direction of the flow while monitoring permanently the functioning parameters of the engine and of the complete hydraulic system.
- Two contamination resistant (IP65) solenoid valves controls the displacement and the direction of the flow.
- A sensor linked to the swash plate monitors permanently the actual displacement setting.



For SD Master and SD Premier ECU use SA control whatever the supply voltage (12V or 24V).

	Shaft rotation			
	Clockwise		counter clockwise	
Actuated solenoid	S1	S2	S1	S2
Servo cylinder	M5	M4	M5	M4
Port A flow	outlet	inlet	inlet	outlet
Port B flow	inlet	outlet	outlet	inlet

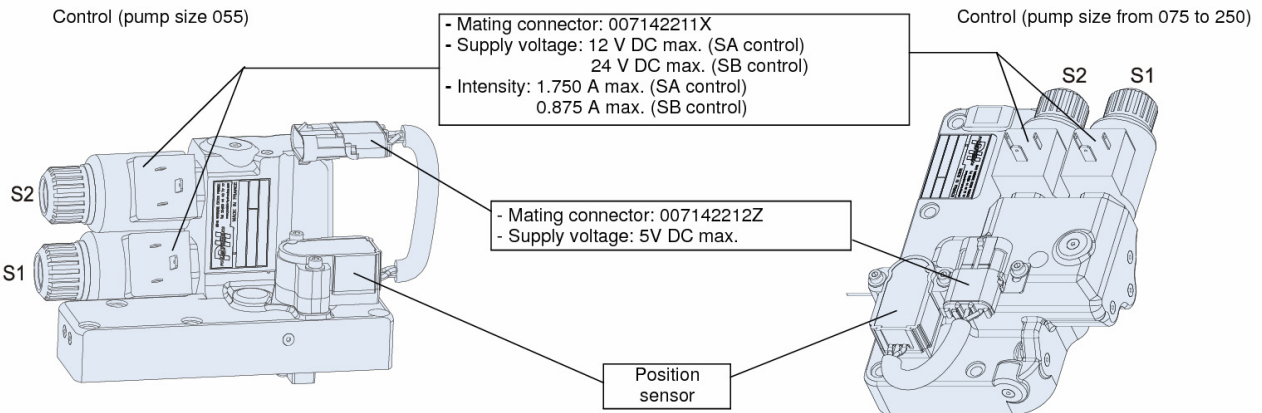

Pump displacement	Feedback angle for max displacement
055	19.2°
075	16.4°
100	19.1°
130	17.4°
180/250	19.5°

Hydraulic symbol :

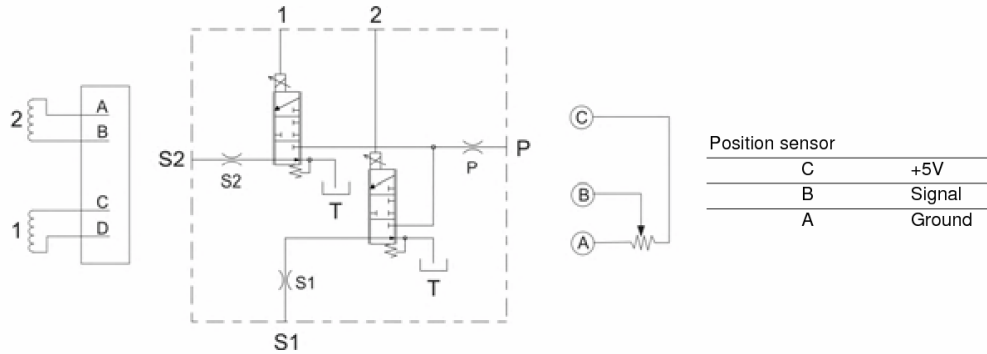

FRAME SIZE 055

Control SA or SB, Side ports

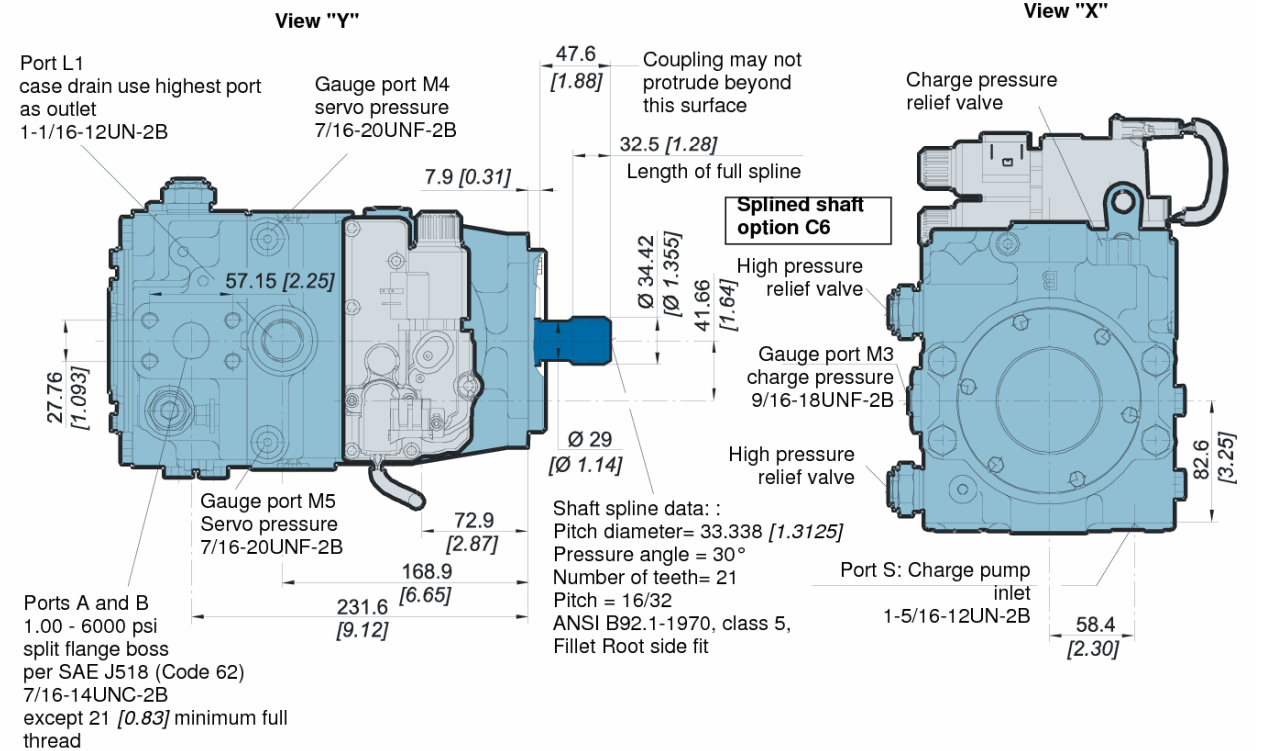
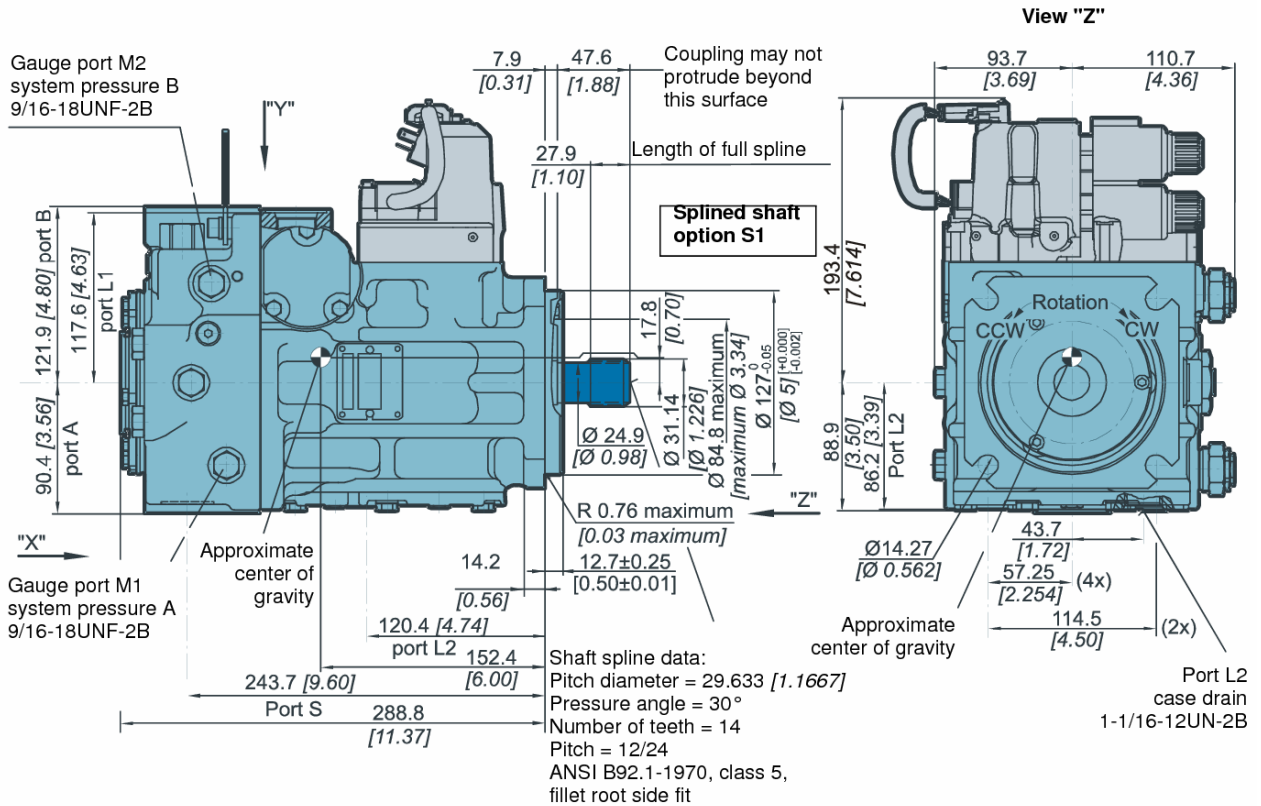

Control SA or SB, Twin ports

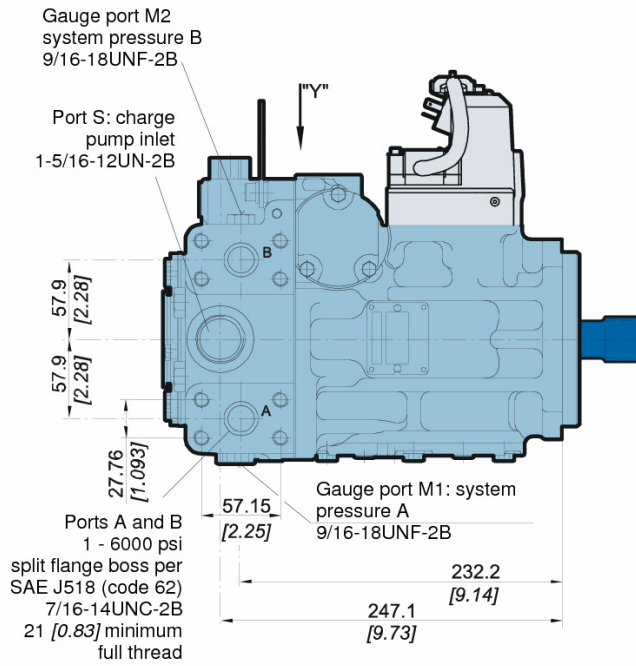

View "Y"

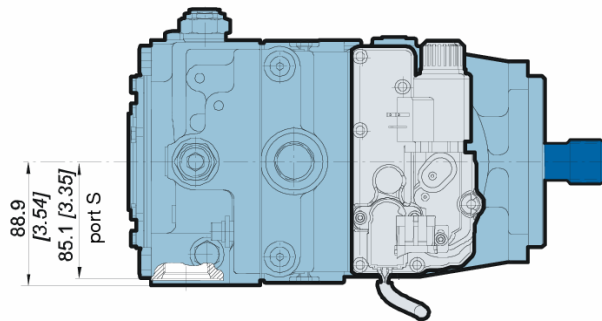

SAE A (option AB), Side ports

Coupling spline data:
 Pitch diameter = 14.288 [0.5625]
 Pressure angle = 30°
 Number of teeth = 9
 Pitch = 16/32
 ANSI B92.1-1970, class 6,
 fillet root side fit
 Length of spline = 37.13 [1.46]

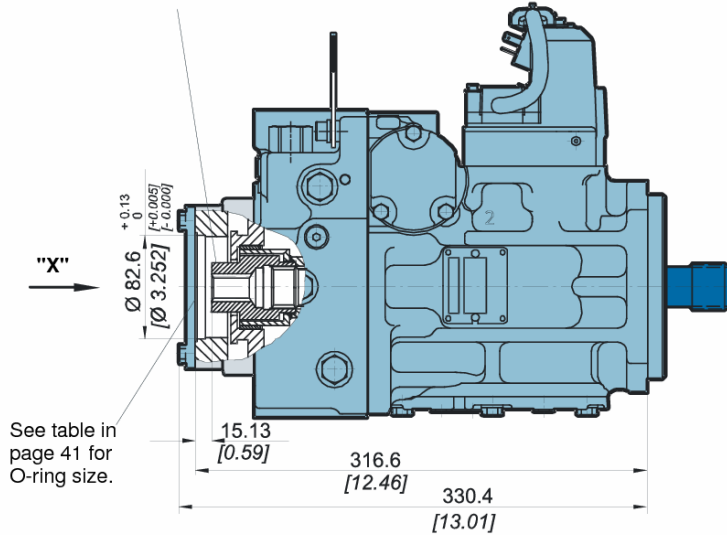

View "X"

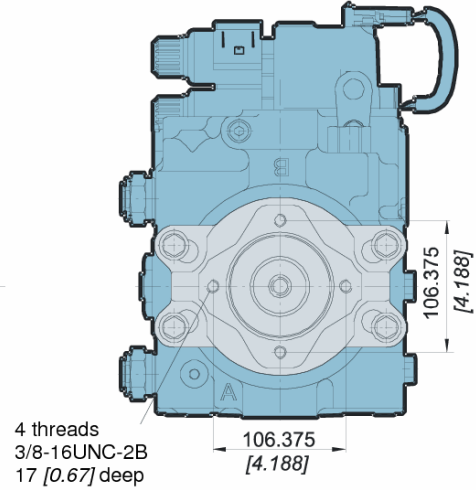

SAE B (option BC), Side ports

Coupling spline data:
 Pitch diameter = 20.6375 [0.8125]
 Pressure angle = 30°
 Number of teeth = 13
 Pitch = 16/32
 ANSI B92.1-1970, class 6,
 fillet root side fit
 Length of spline = 29.51 [1.16]

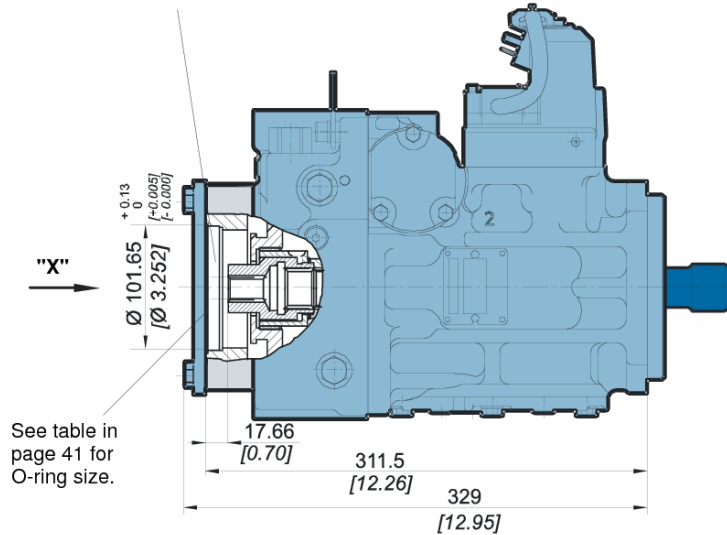

View "X"

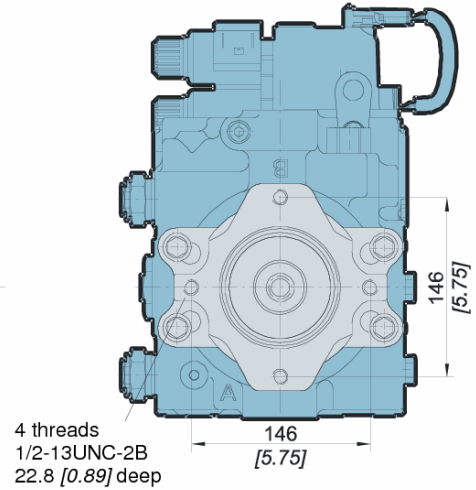

SAE C (option CD), Side ports

Coupling spline data:
 Pitch diameter = 29.6333 [1.167]
 Pressure angle = 30°
 Number of teeth = 14
 Pitch = 12/24
 ANSI B92.1-1970, class 6,
 fillet root side fit
 Length of spline = 18.97 [0.747]

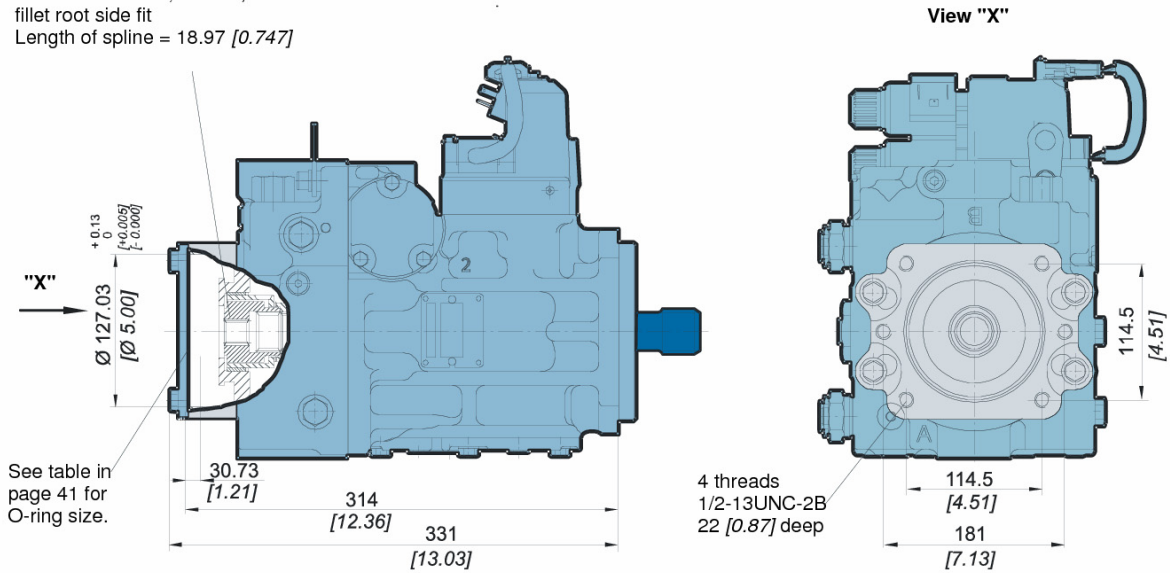

SAE B-B (option BB), Side ports

Coupling spline data: :
 Pitch diameter = 23.8125 [0.9375]
 Pressure angle = 30°
 Number of teeth = 15
 Pitch = 16/32
 ANSI B92.1-1970, class 6,
 fillet root side fit
 Length of spline = 24.43 [0.96]

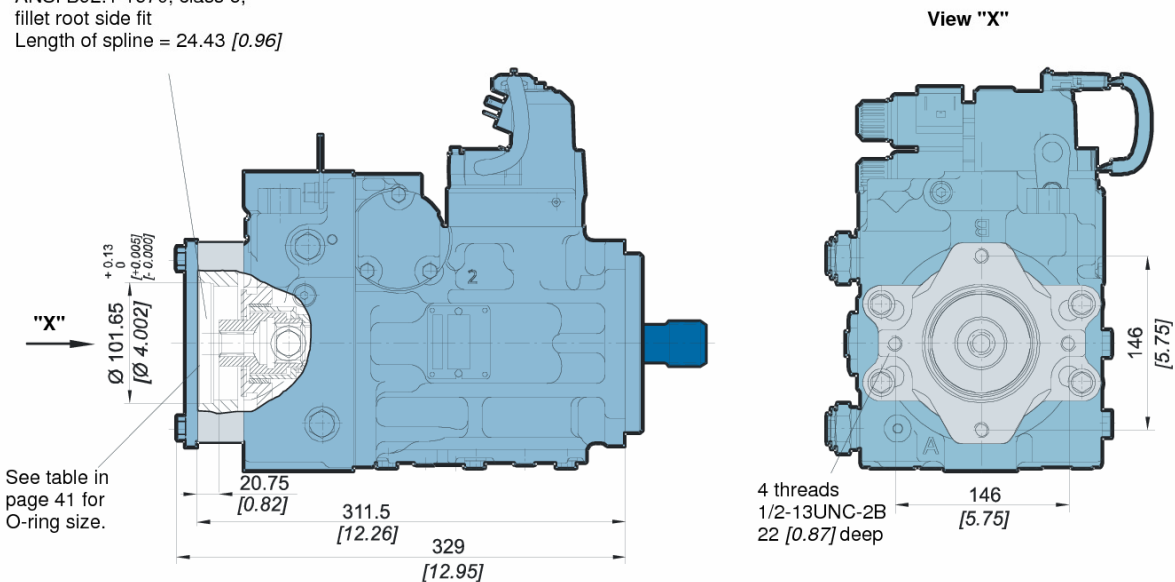

FRAME SIZE 075

Control SA or SB, Side ports

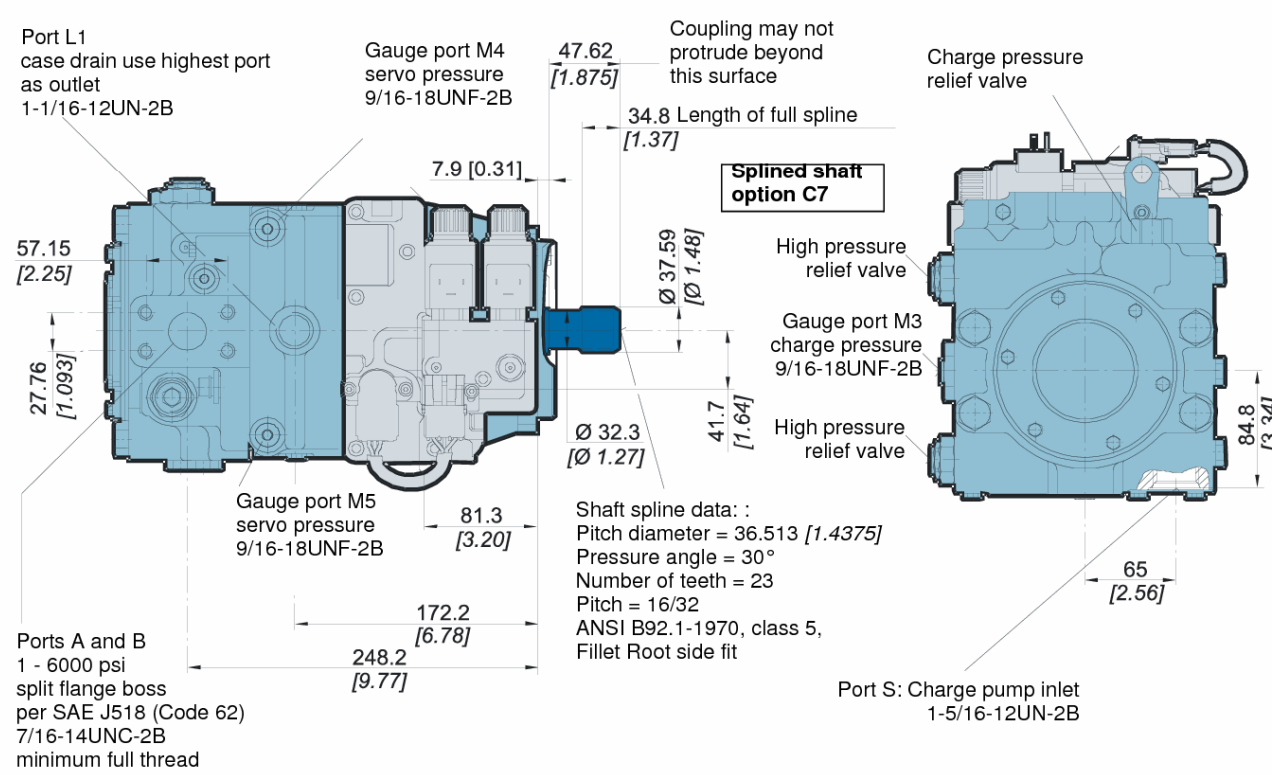
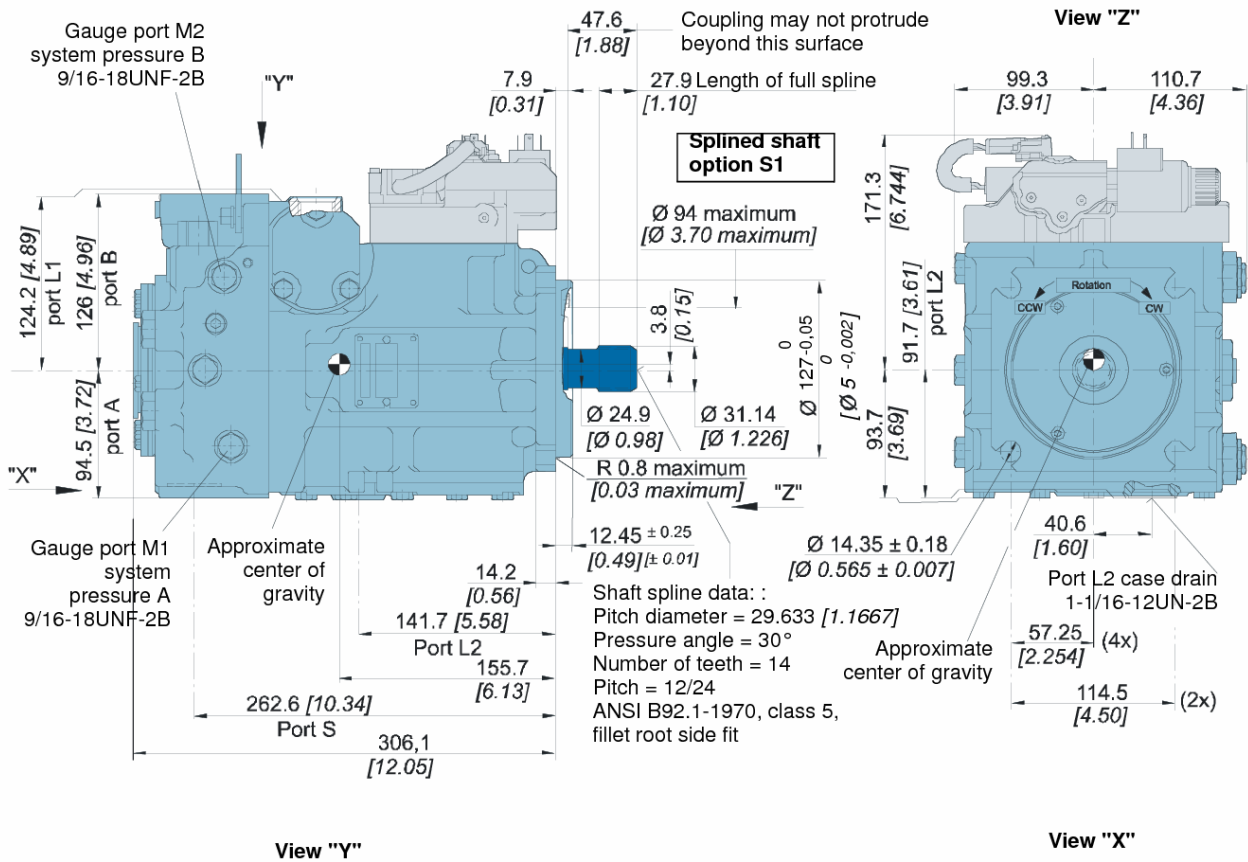

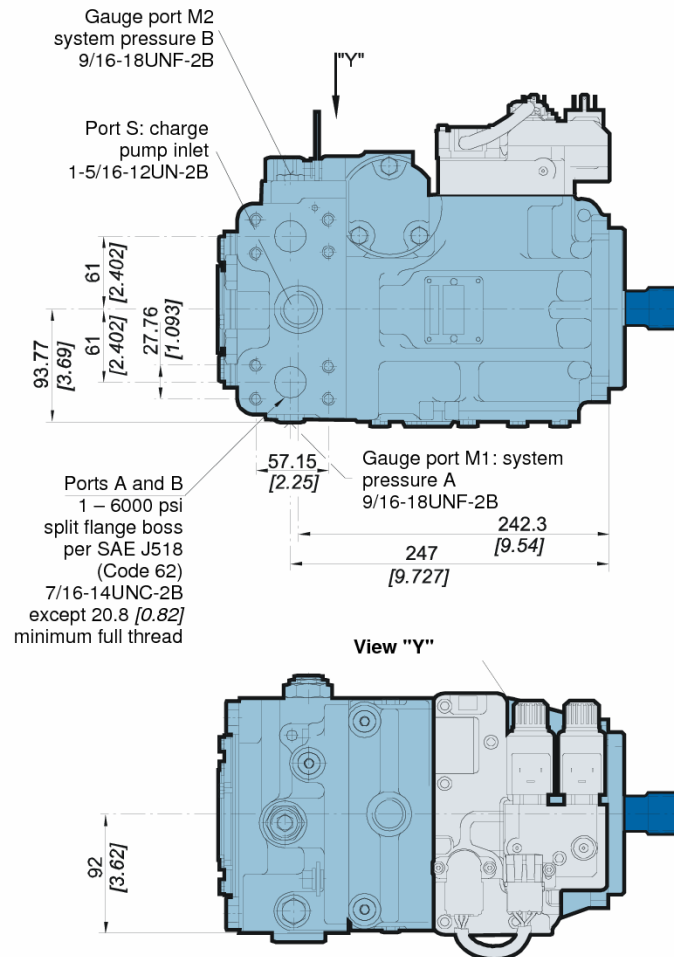
Control SA or SB, Twin ports

SAE A (option AB), Side ports

Coupling spline data: :
 Pitch diameter = 14.288 [0.5625]
 Pressure angle = 30°
 Number of teeth = 9
 Pitch = 16/32
 ANSI B92.1-1970, class 6,
 fillet root side fit
 Length of spline = 37.13 [1.46]

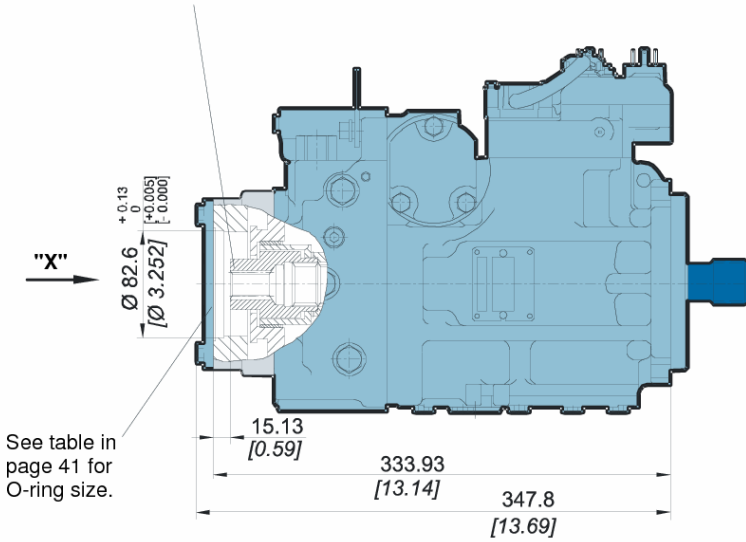

View "X"

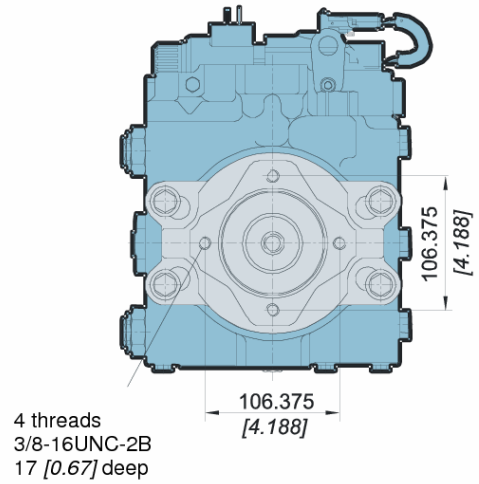

SAE B (option BC), Side ports

Coupling spline data: :
 Pitch diameter = 20.6375 [0.8125]
 Pressure angle = 30°
 Number of teeth = 13
 Pitch = 16/32
 ANSI B92.1-1970, class 6,
 fillet root side fit
 Length of spline = 29.51 [1.16]

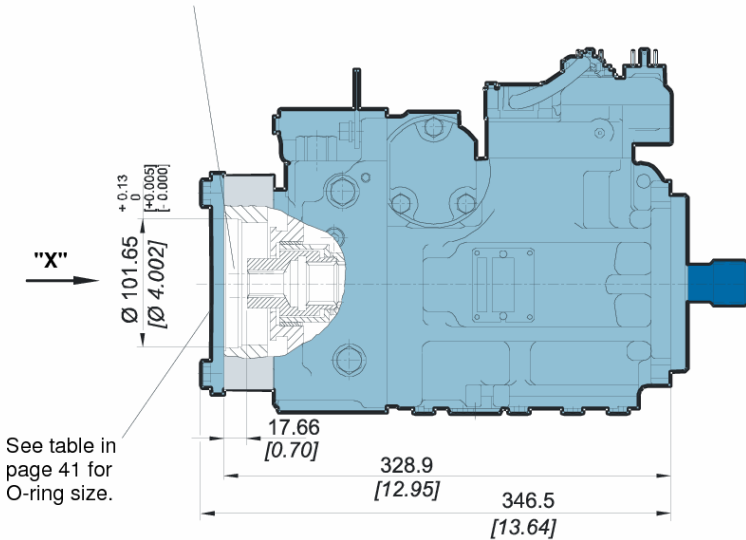

View "X"

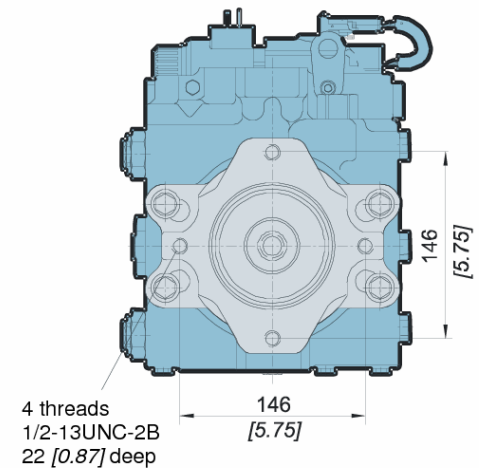

SAE C (option CD), Side ports

Coupling spline data:
 Pitch diameter = 29.6333 [1.167]
 Pressure angle = 30°
 Number of teeth = 14
 Pitch = 12/24
 ANSI B92.1-1970, class 6,
 fillet root side fit
 Length of spline = 18.97 [0.747]

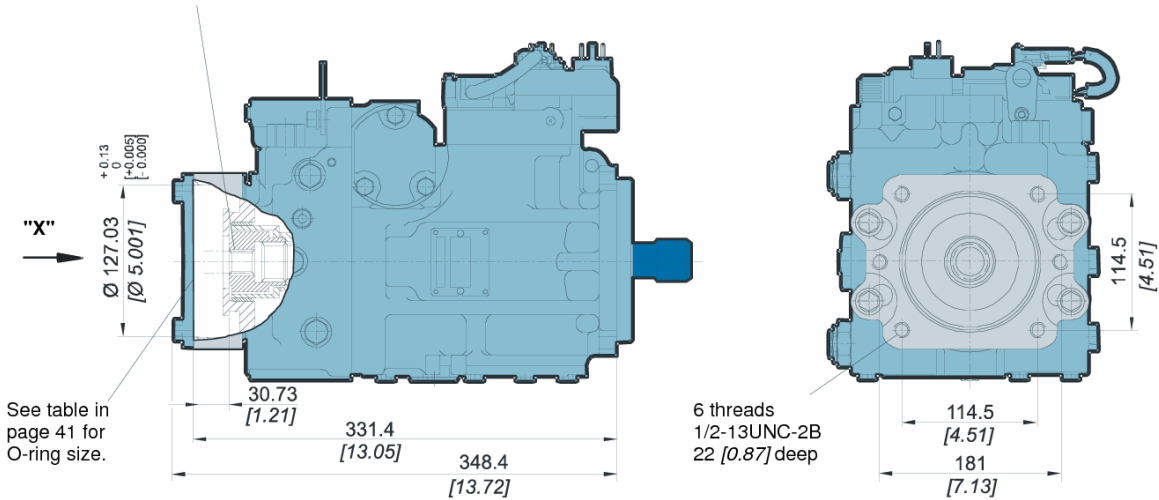

SAE B-B (option BB), side ports

Coupling spline data: :
 Pitch diameter = 23.8125 [0.9375]
 Pressure angle = 30°
 Number of teeth = 15
 Pitch = 16/32
 ANSI B92.1-1970, class 6,
 fillet root side fit
 Length of spline = 24.43 [0.96]

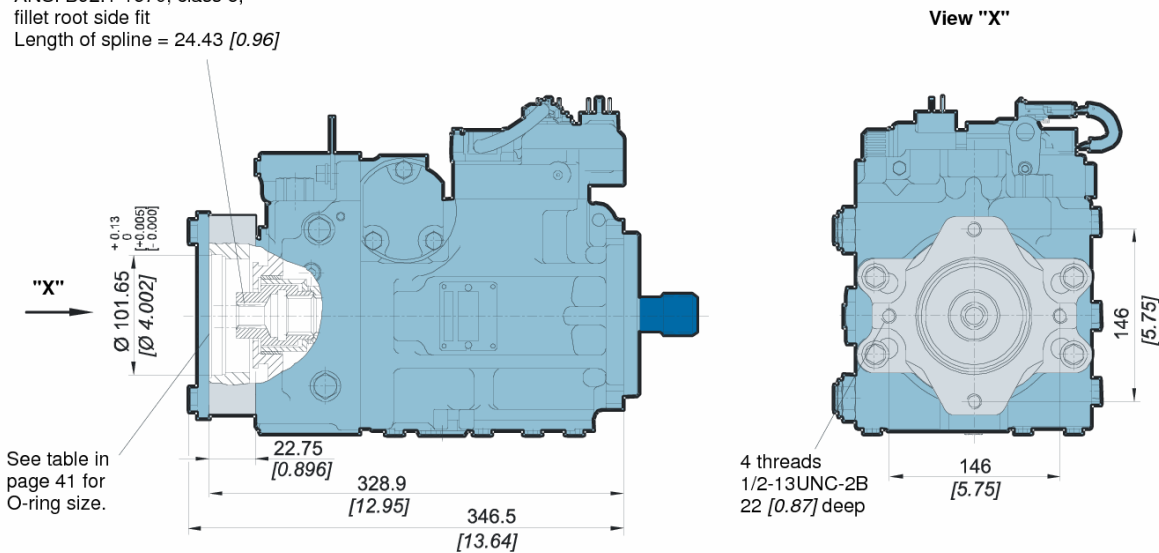

FRAME SIZE 100

Control SA or SB, Side ports

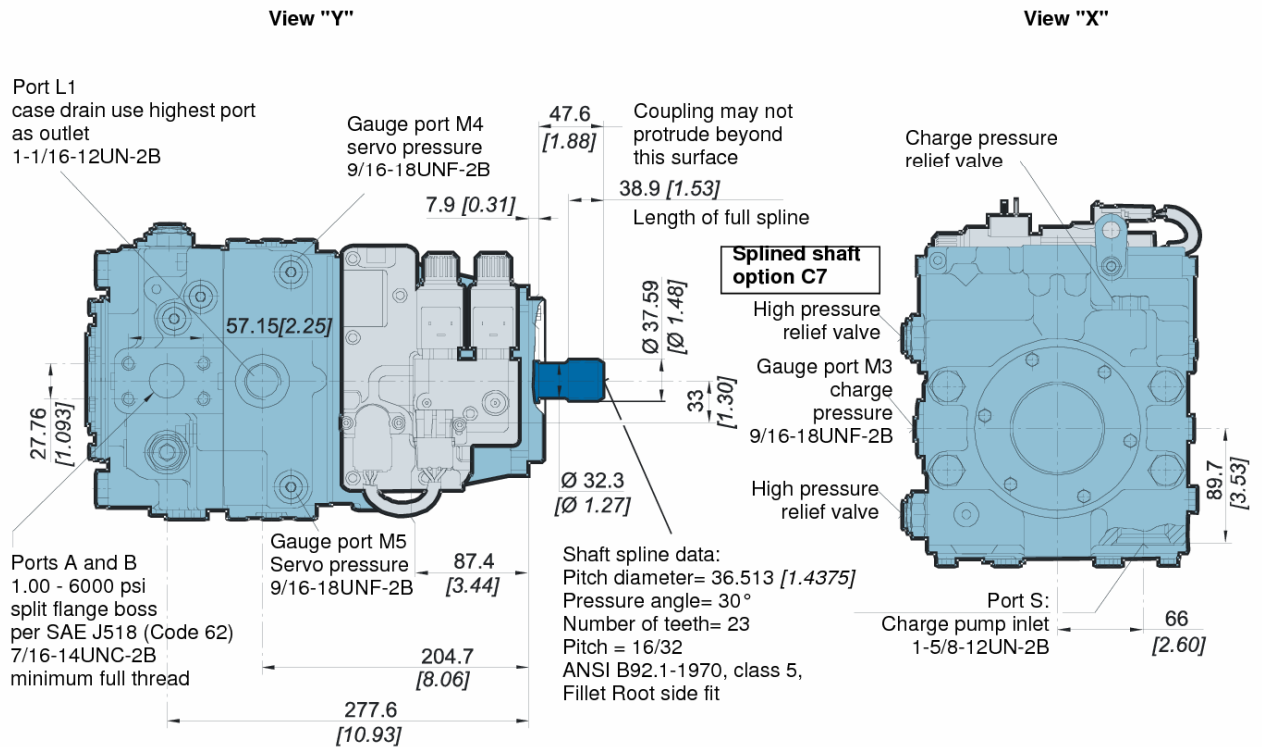
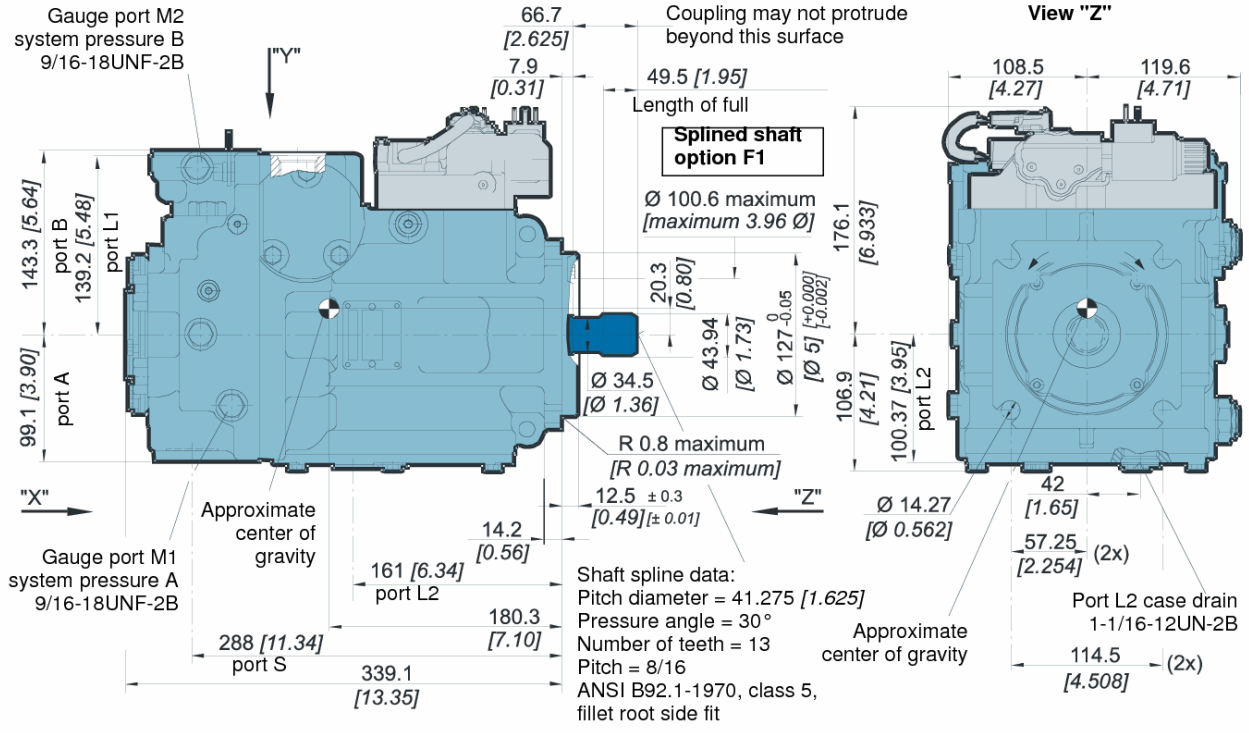

Control SA or SB, Twin ports

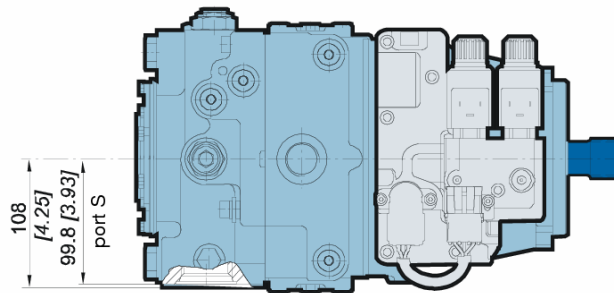
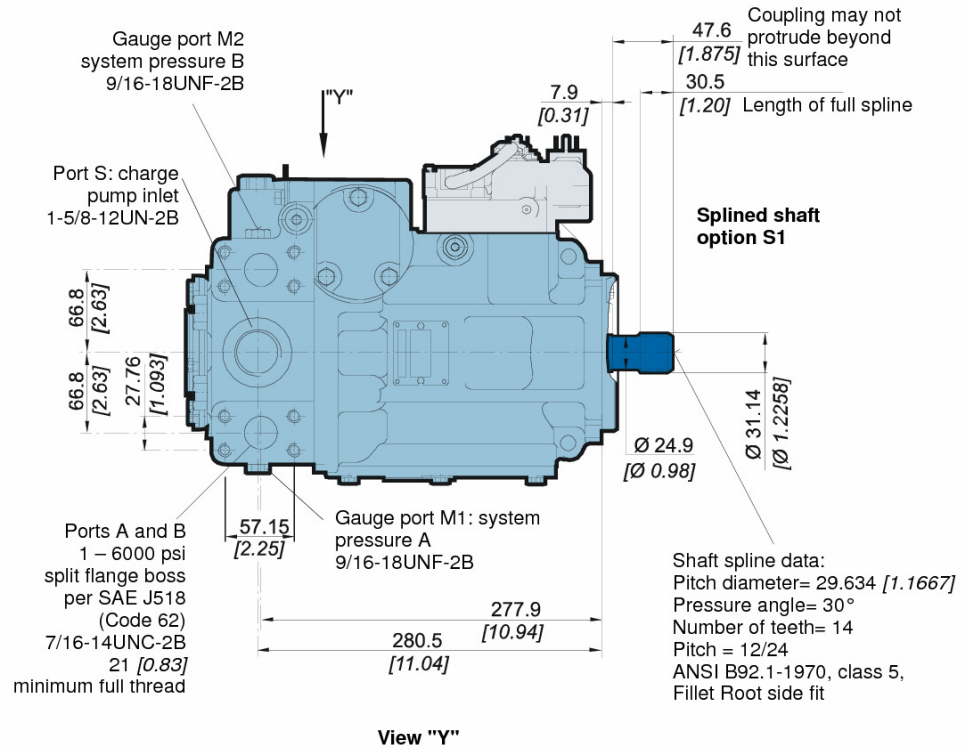

FRAME SIZE 130

Control SA or SB, Twin ports

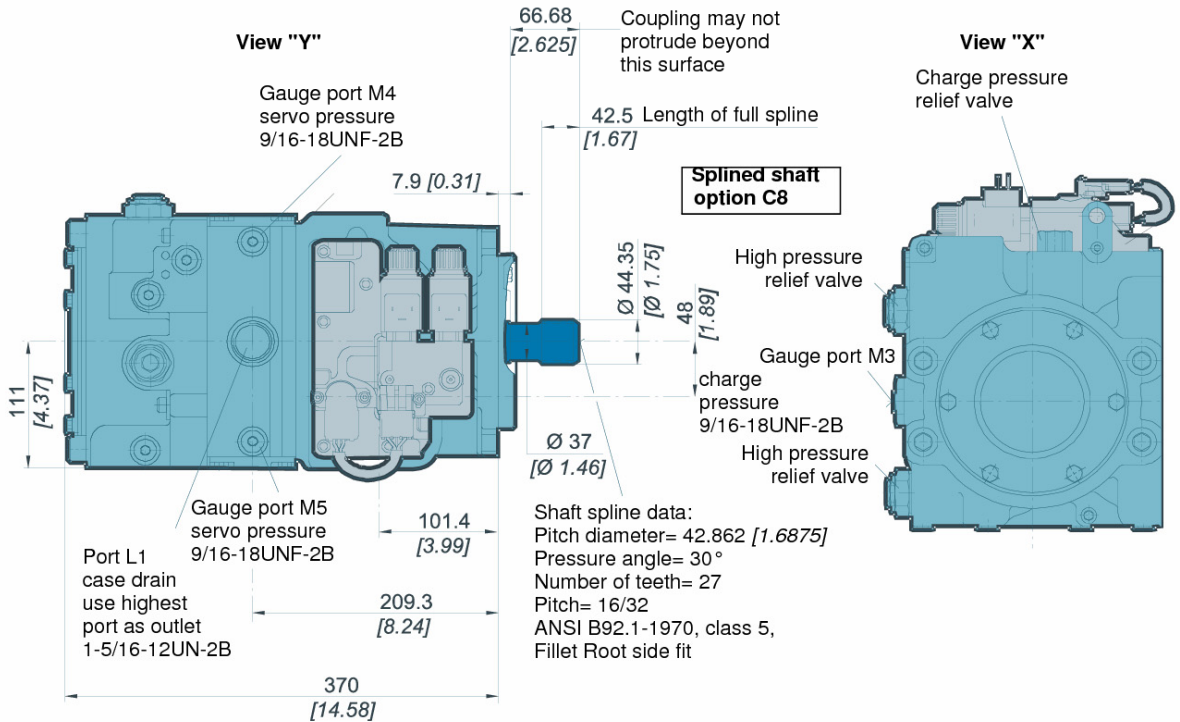
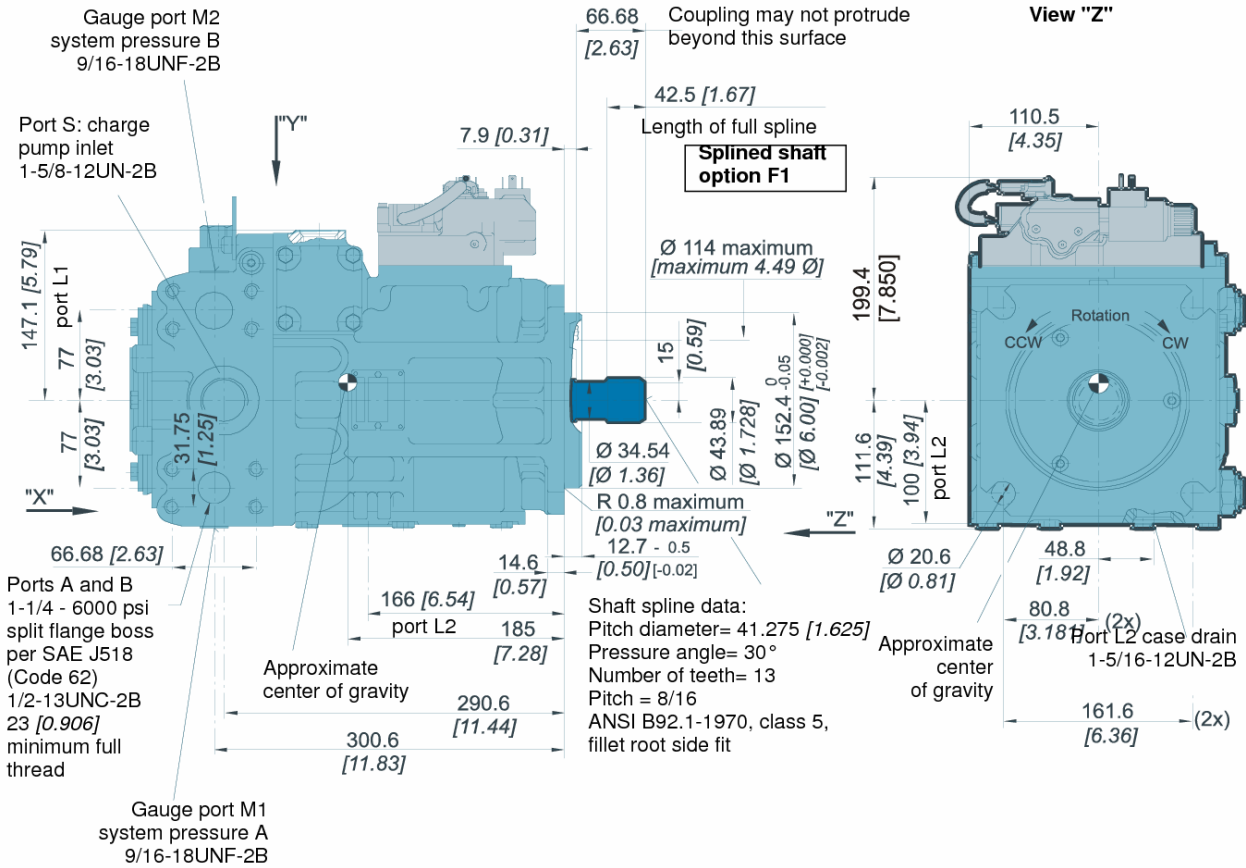

SAE A (option AB), Twin ports

Coupling spline data:
 Pitch diameter = 14.288 [0.5625]
 Pressure angle = 30°
 Number of teeth = 9
 Pitch = 16/32
 ANSI B92.1-1970, class 6,
 fillet root side fit
 Length of spline = 22.4 [0.88]

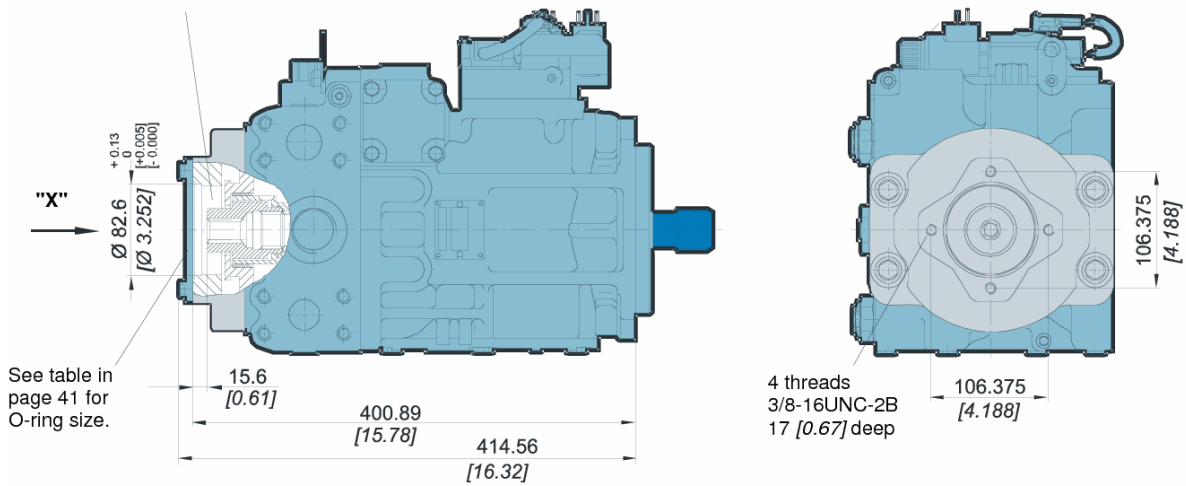

SAE B (option BC), Twin ports

Coupling spline data:
 Pitch diameter = 20.6375 [0.8125]
 Pressure angle = 30°
 Number of teeth = 13
 Pitch = 16/32
 ANSI B92.1-1970, class 6,
 fillet root side fit
 Length of spline = 28.77 [1.1]

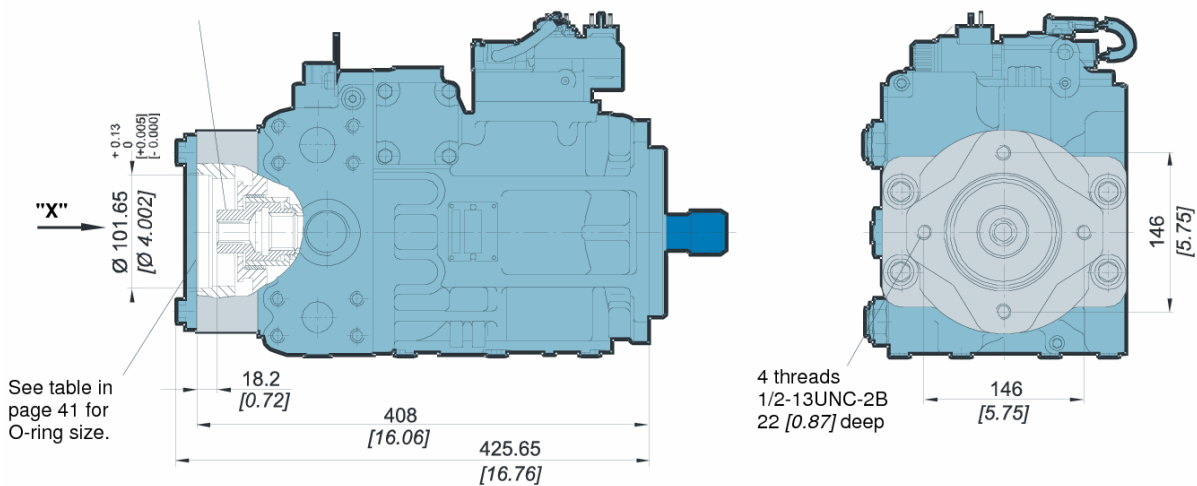

SAE C (option CD), Twin ports

Coupling spline data:
 Pitch diameter = 29.6333 [1.167]
 Pressure angle = 30°
 Number of teeth = 14
 Pitch = 12/24
 ANSI B92.1-1970, class 6,
 fillet root side fit
 Length of spline = 29.97 [1.18]

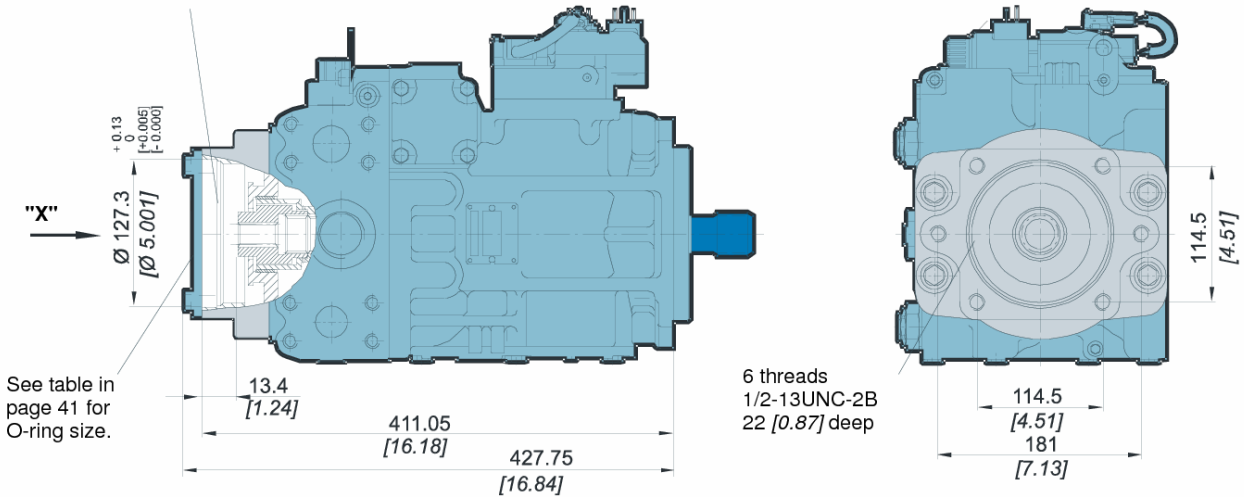

SAE D (option DE), Twin ports

Coupling spline data:
 Pitch diameter = 41.275 [1.625]
 Pressure angle = 30°
 Number of teeth = 13
 Pitch = 8/16
 ANSI B92.1-1970, class 6,
 fillet root side fit
 Length of spline = 25.22 [0.993]

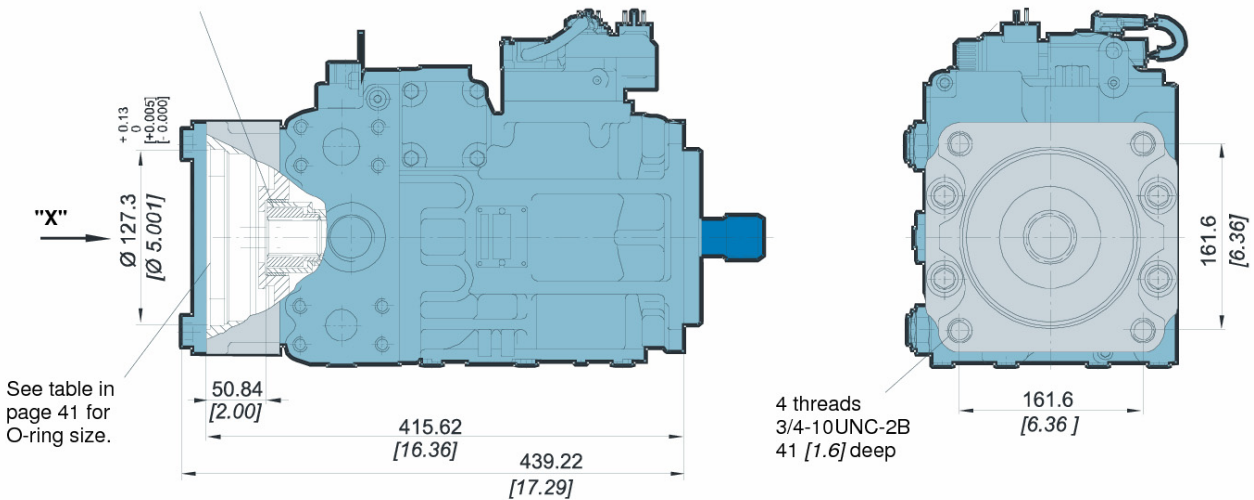

SAE B-B (option BB), Twin ports

Coupling spline data:
 Pitch diameter = 23.8125 [0.9375]
 Pressure angle = 30°
 Number of teeth = 15
 Pitch = 16/32
 ANSI B92.1-1970, class 6,
 fillet root side fit
 Length of spline = 24.43 [0.96]

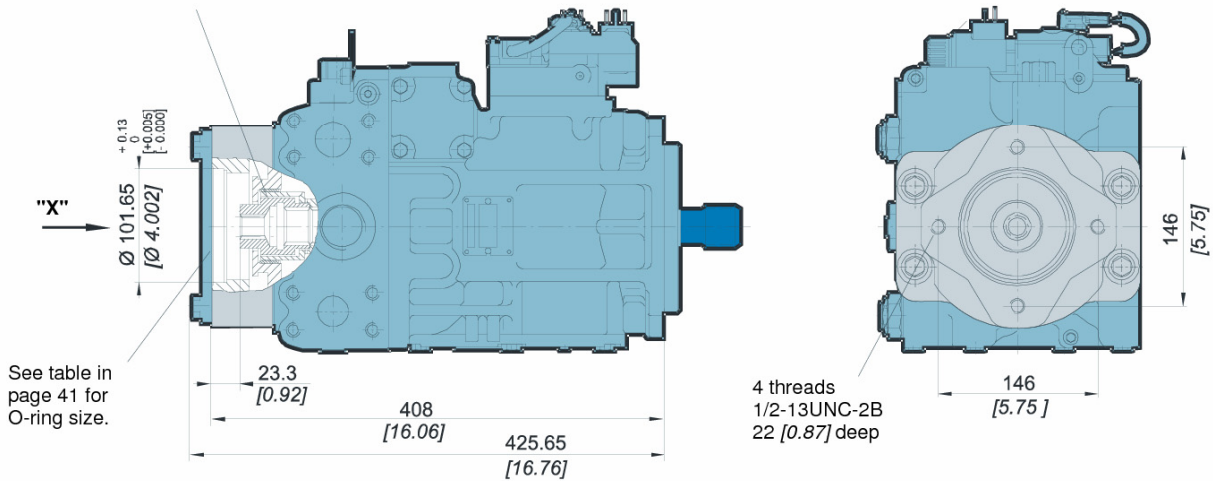

FRAME SIZE 180

Control SA or SB, Twin ports

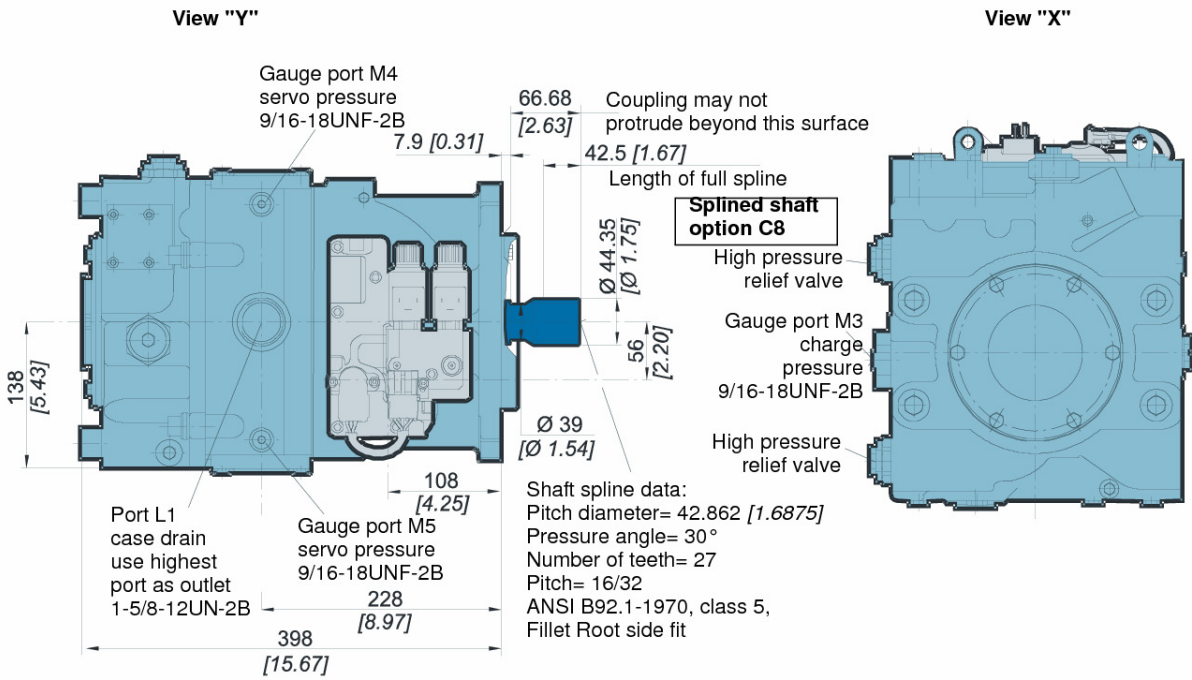
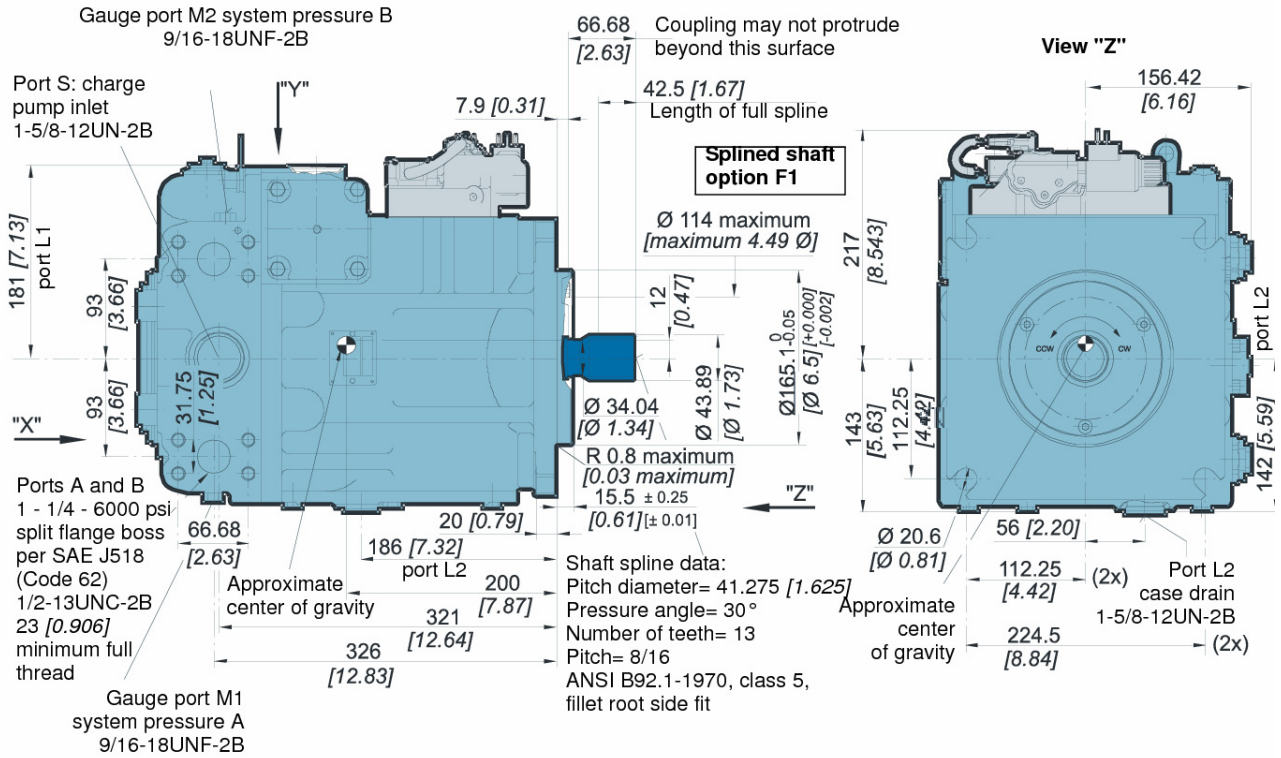

SAE A (option AB), Twin ports

Coupling spline data:
 Pitch diameter = 14.288 [0.5625]
 Pressure angle = 30°
 Number of teeth = 9
 Pitch = 16/32
 ANSI B92.1-1970, class 6,
 fillet root side fit
 Length of spline = 17.8 [0.70]

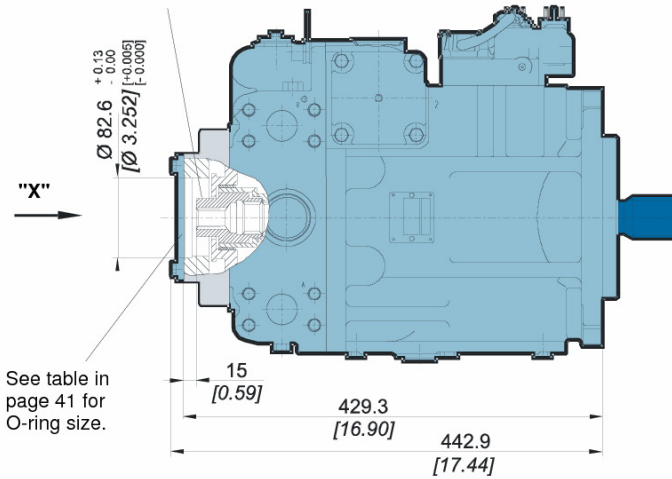

View "X"

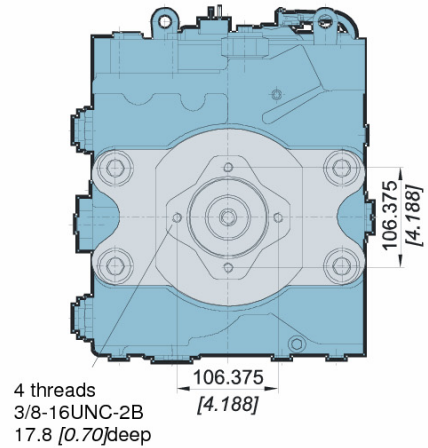

SAE B (option BC), Twin ports

Coupling spline data:
 Pitch diameter = 20.6375 [0.8125]
 Pressure angle = 30°
 Number of teeth = 13
 Pitch = 16/32
 ANSI B92.1-1970, class 6,
 fillet root side fit
 Length of spline = 29.5 [1.16]

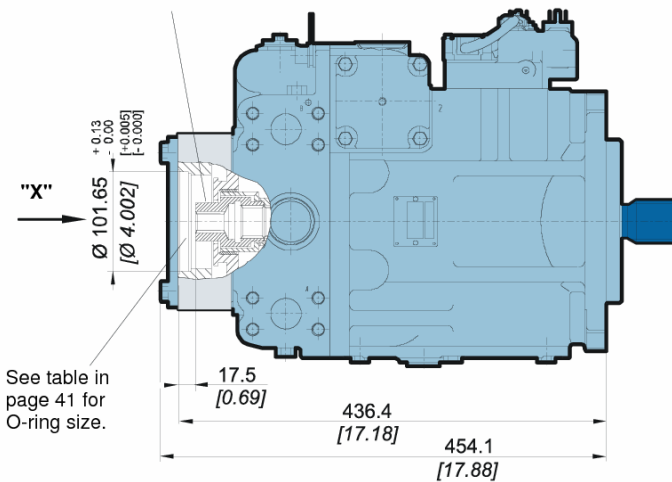

View "X"

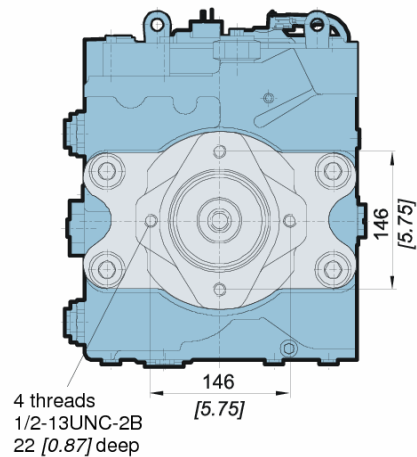

SAE C (option CD), Twin ports

Coupling spline data:
 Pitch diameter = 29.6333 [1.167]
 Pressure angle = 30°
 Number of teeth = 14
 Pitch = 12/24
 ANSI B92.1-1970, class 6,
 fillet root side fit
 Length of spline = 22.1 [0.87]

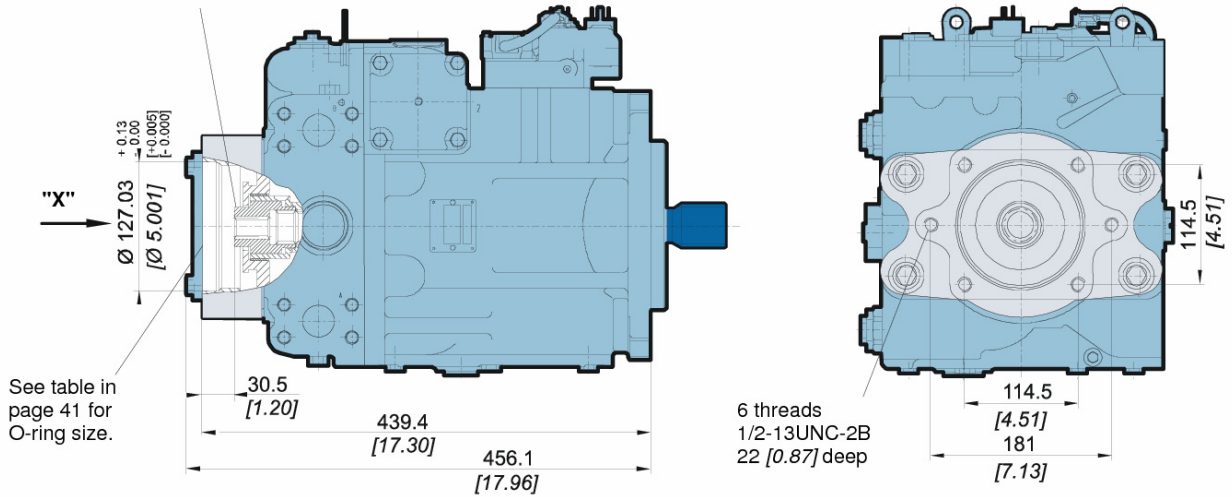

SAE D (option DE), Twin ports

Coupling spline data:
 Pitch diameter = 41.475 [1.625]
 Pressure angle = 30°
 Number of teeth = 13
 Pitch = 8/16
 ANSI B92.1-1970, class 6,
 Length of spline = 25.9 [1.02]

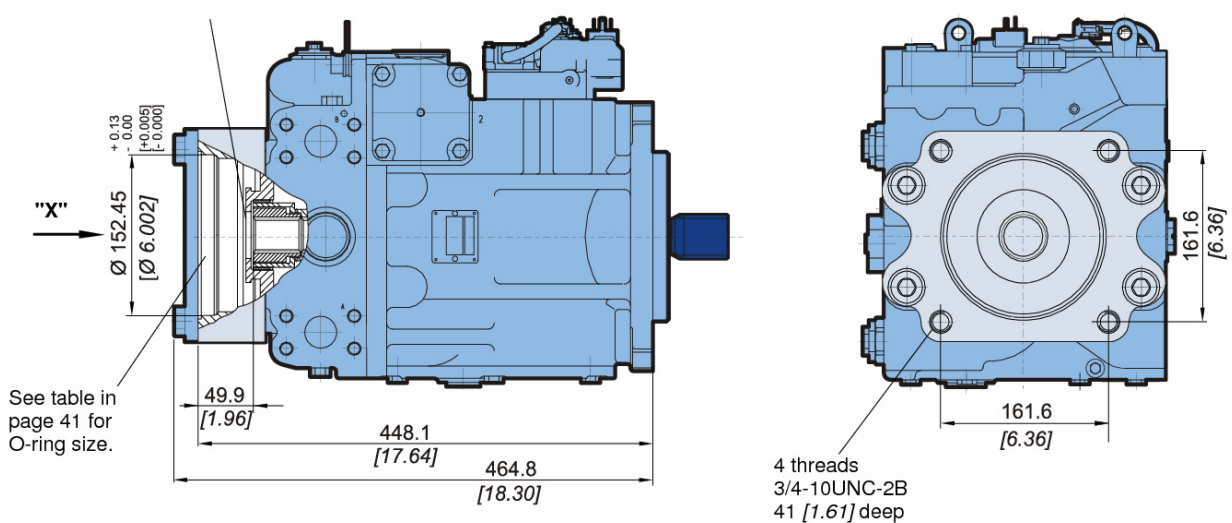

SAE E (option EF), Twin ports

Coupling spline data:
 Pitch diameter = 41.273 [1.625]
 Pressure angle = 30°
 Number of teeth = 14
 Pitch = 8/16
 ANSI B92.1-1970, class 6,
 fillet root side fit
 Length of spline = 25.9 [1.02]

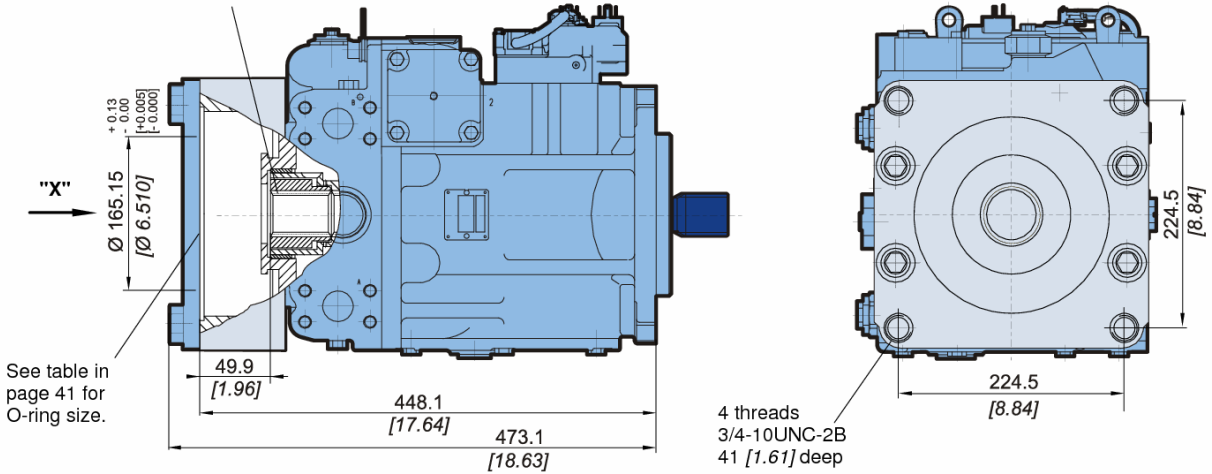

SAE B-B (option BB), Twin ports

Coupling spline data:
 Pitch diameter = 23.8125 [0.9375]
 Pressure angle = 30°
 Number of teeth = 15
 Pitch = 16/32
 ANSI B92.1-1970, class 6,
 fillet root side fit
 Length of spline = 24.49 [0.96]

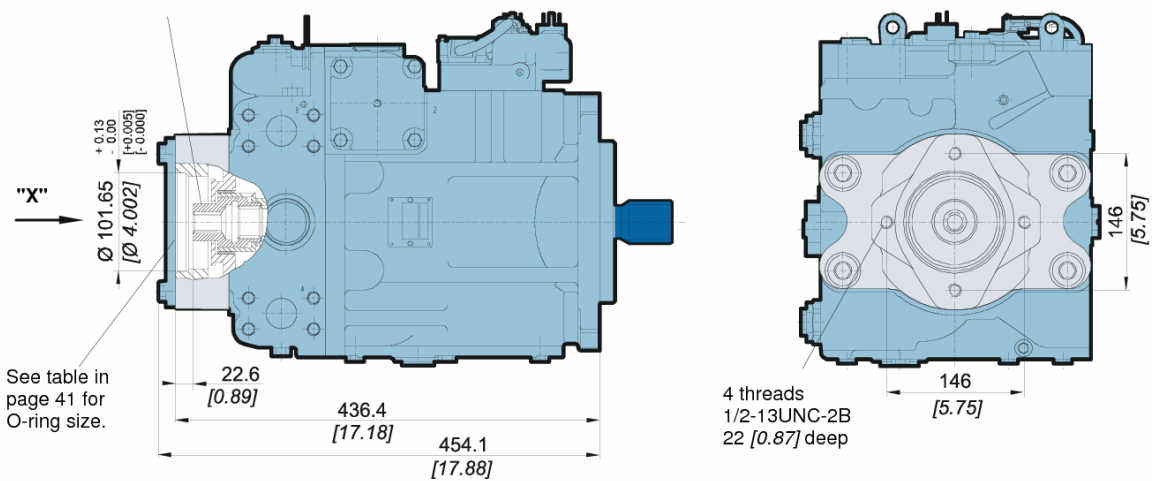

FRAME SIZE 250

Control SA or SB, Twin ports

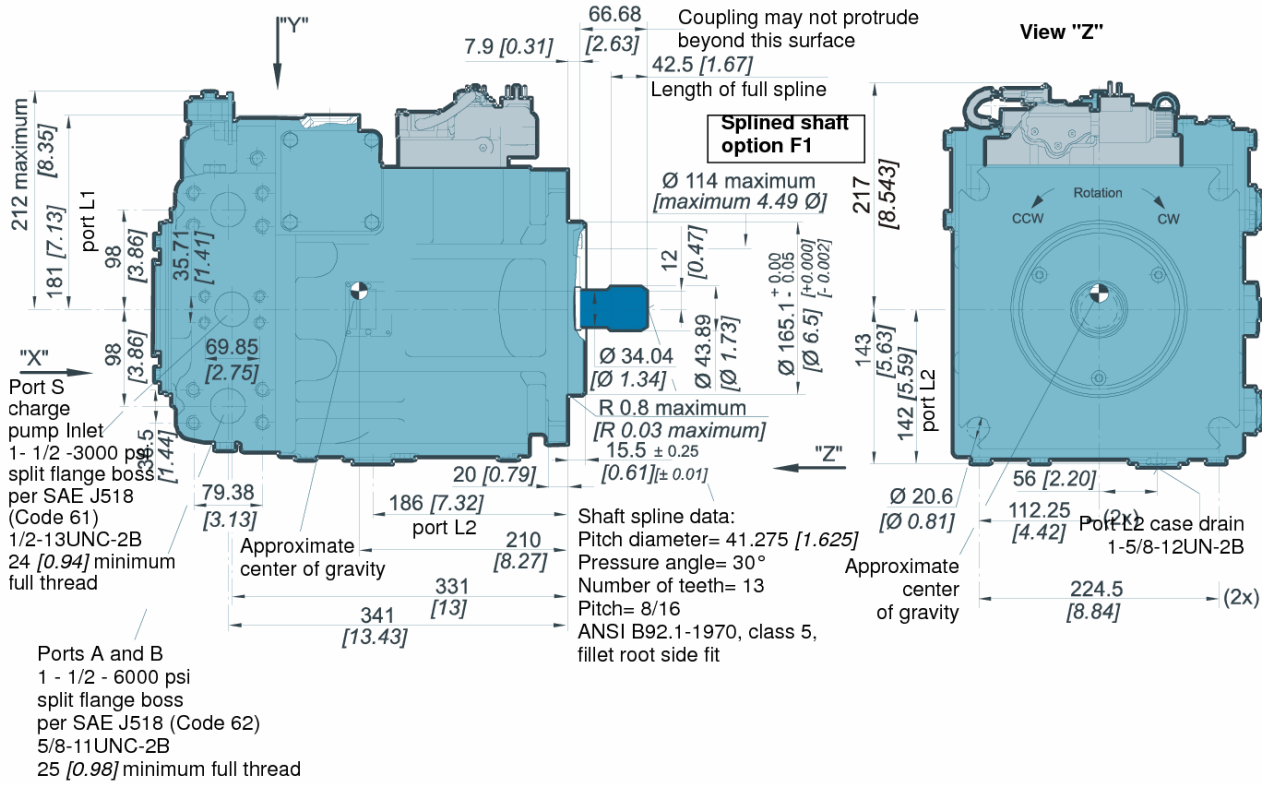

SAE A (option AB), Twin ports

Coupling spline data:
 Pitch diameter= 14.288 [0.5625]
 Pressure angle= 30°
 Number of teeth= 9
 Pitch= 16/32
 ANSI B92.1-1970, class 6,
 fillet root side fit
 Length of spline= 17.8 [0.70]

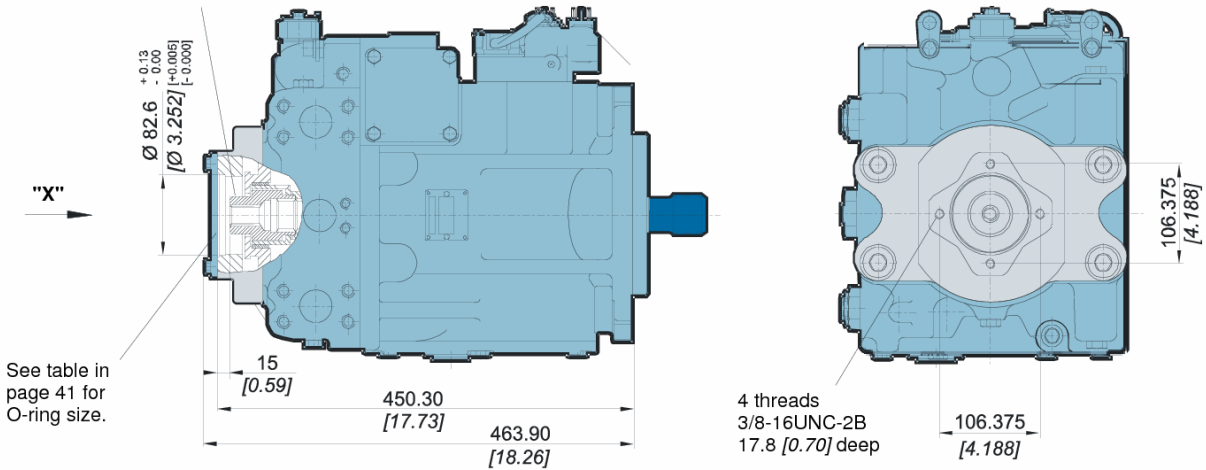

SAE B (option BC), Twin ports

Coupling spline data:
 Pitch diameter= 20.6375 [0.8125]
 Pressure angle= 30°
 Number of teeth= 13
 Pitch= 16/32
 ANSI B92.1-1970, class 6,
 fillet root side fit
 Length of spline= 29.5 [1.16]

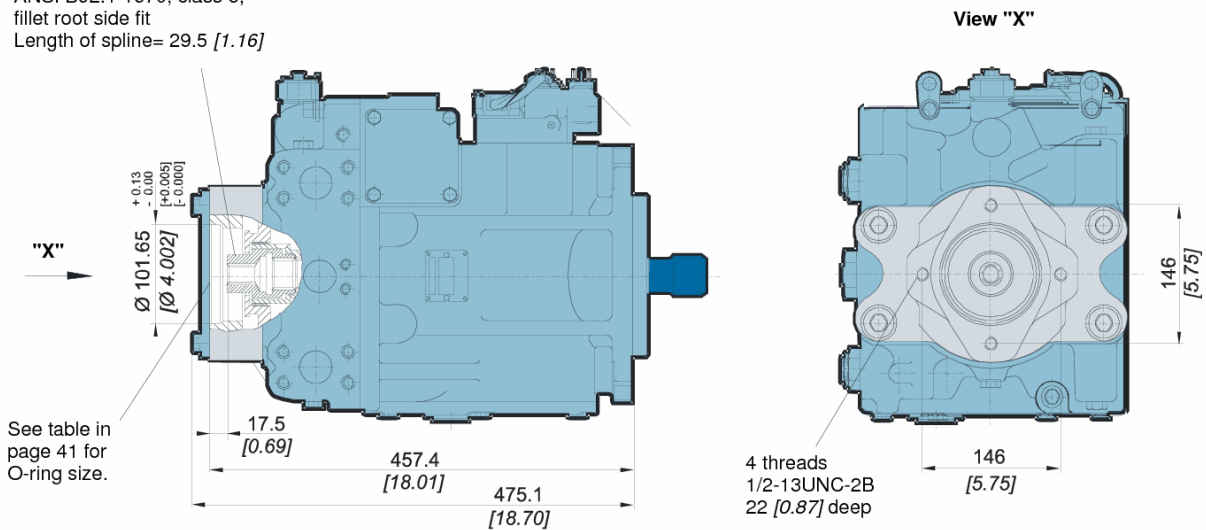

SAE C (option CD), Twin ports

Coupling spline data:
 Pitch diameter= 29.6333 [1.167]
 Pressure angle= 30°
 Number of teeth= 14
 Pitch= 12/24
 ANSI B92.1-1970, class 6,
 fillet root side fit
 Length of spline= 22.1 [0.87]

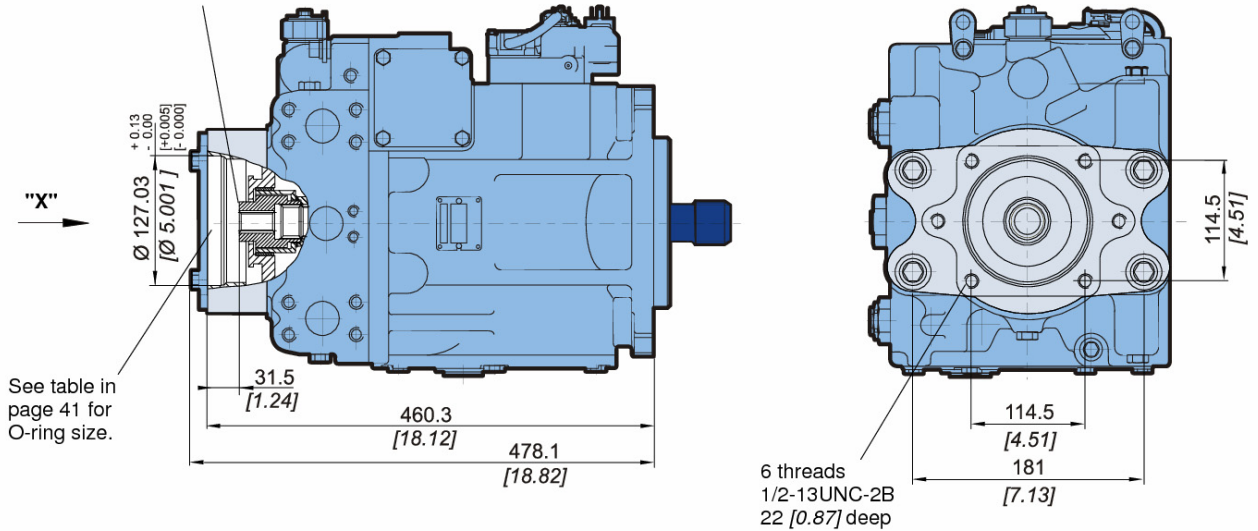

SAE D (option DE), Twin ports

Coupling spline data:
 Pitch diameter= 41.275 [1.625]
 Pressure angle= 30°
 Number of teeth= 13
 Pitch= 8/16
 ANSI B92.1-1970, class 6,
 fillet root side fit
 Length of spline= 25.9 [1.02]

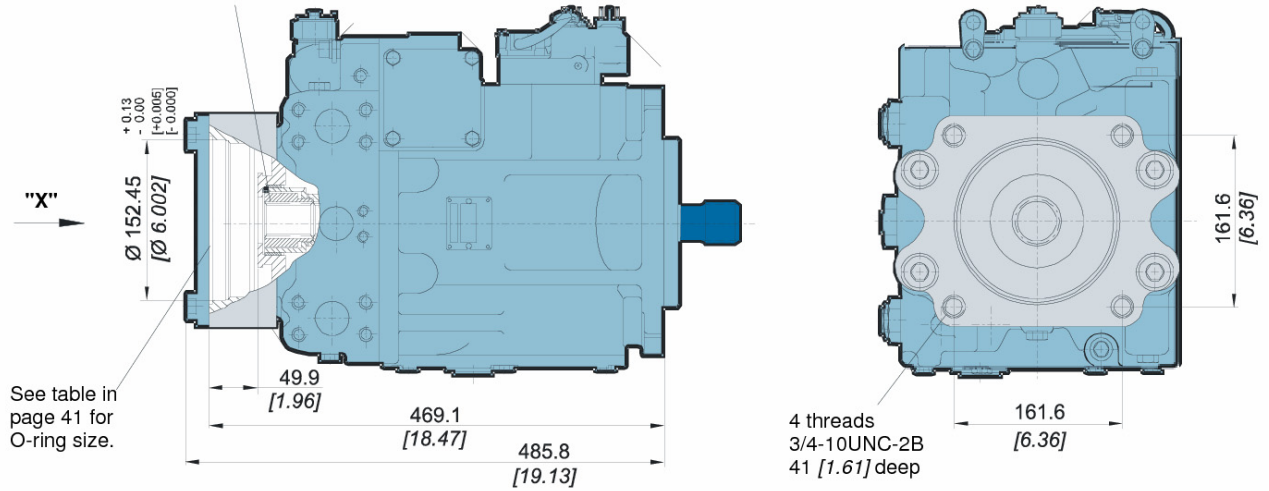

SAE E (option EF), Twin ports

Coupling spline data:
 Pitch diameter= 41.275 [1.625]
 Pressure angle= 30°
 Number of teeth= 13
 Pitch= 8/16
 ANSI B92.1-1970, class 6,
 fillet root side fit
 Length of spline= 25.9 [1.02]

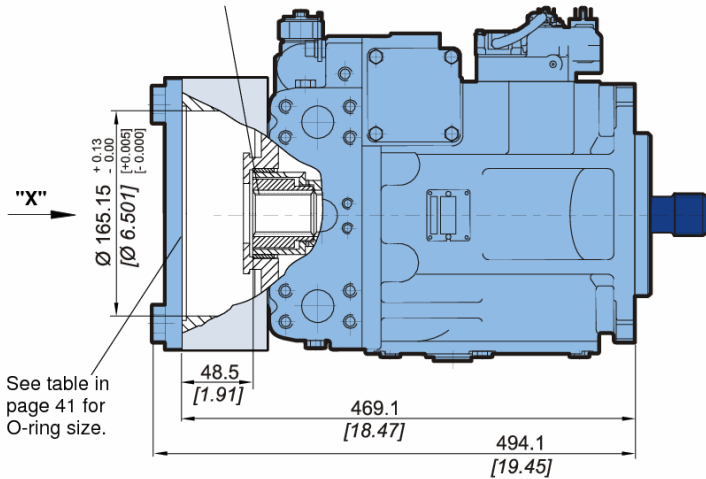

View "X"

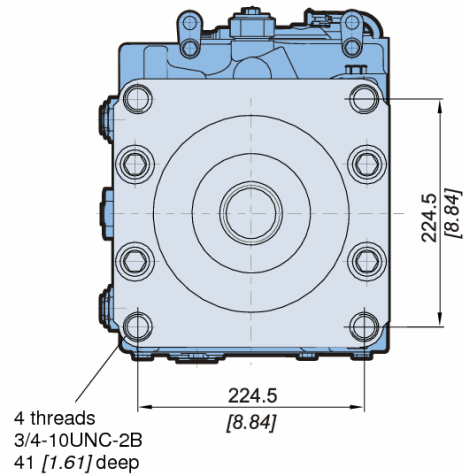

SAE B-B (option BB), Twin ports

Coupling spline data:
 Pitch diameter= 23.8125 [0.9375]
 Pressure angle= 30°
 Number of teeth= 15
 Pitch= 16/32
 ANSI B92.1-1970, class 6,
 fillet root side fit
 Length of spline= 24.49 [0.96]

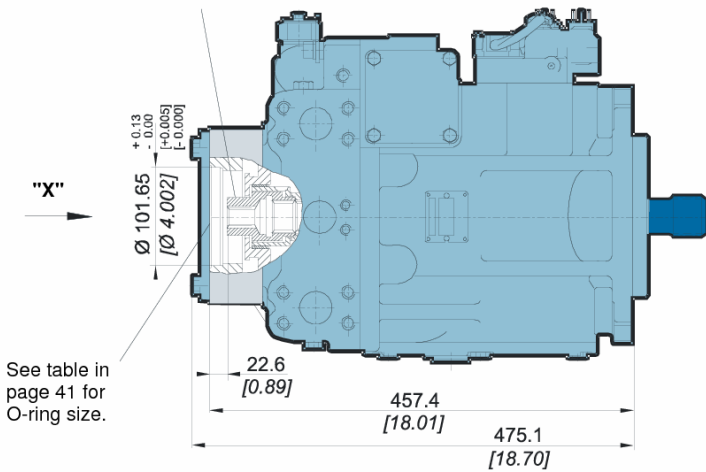

View "X"

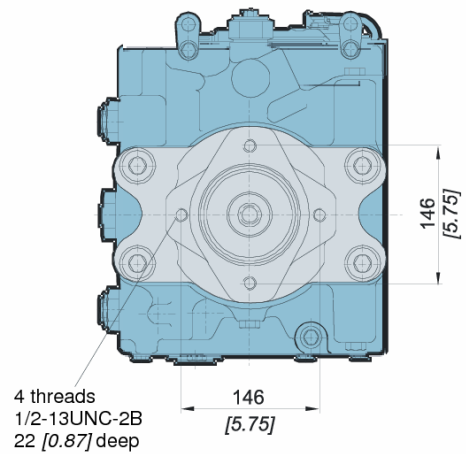

O-ring size according to flange type

Flange type	O-ring size	O-ring material	P/N
SAE A	82.22x2.62	FPM 70 shore A	001830433B
SAE B and SAE B-B	94.92x2.62	FPM 70 shore A	A25721H
SAE C	120.32x2.62	FPM 70 shore A	001830456B
SAE D	150x3	FPM 80 shore A	A19528B
SAE E	164.77x2.62	FPM 80 shore A	A19530D

OPTIONS

Shaft availability and torque ratings

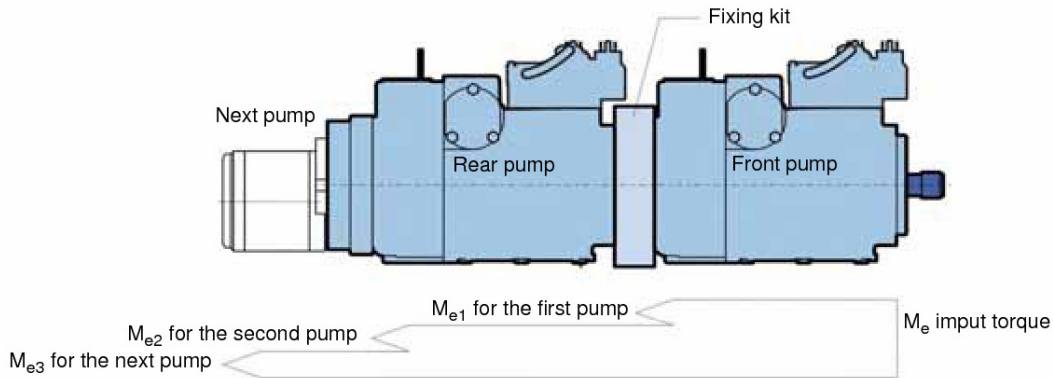

Torque required by auxiliary pumps is additive. Ensure requirements don't exceed shaft torque ratings.

Shaft availability and torque ratings Types d'arbres disponibles et couples nominaux N.m [lbf.in]							
Shaft description	Option code	Frame size					
		055	075	100	130	180	250
21 teeth 16/32 pitch spline	C6	1130 [10 000]	—	—	—	—	—
23 teeth 16/32 pitch spline	C7	—	1580 [14 000]	1580 [14 000]	—	—	—
27 teeth 16/32 pitch spline	C8	—	—	—	2938 [26 000]	2938 [26 000]	2938 [26 000]
13 teeth 8/16 pitch spline	F1	—	—	1810 [16 000]	1810 ⁺ [16 000] ⁺	1810 ⁺ [16 000] ⁺	1810 ⁺ [16 000] ⁺
14 teeth 12/24 pitch spline	S1	735 [6 500]	735 [6 500]	735 ⁺ [6 500] ⁺	—	—	—

— Not available + Not recommended for front pump in tandem configurations

Contact your Poclain Hydraulics representative for other shafts ends.

Tandem pump fixing kit								
	Front pump						Kit	tightening torque
	055	075	100	130	180	250		
Rear pump	055	4 x SCREW-HEX HD, 1/2-13UNC X 1.1/4 GRADE 5 (ANSI B18.2.1, SAE J429) + 4 x WASHER DIN6916-13 C45 + 1 x O-RING120.32x2.62 N-FPM80					A19516N	100 N.m
	075							
	100							
	130	4 x SCREW-HEX HD, 3/4 -10 UNC X 2.1/4 GRADE 5 (ANSI B18.2.1, SAE J429) + 4 x WASHER-.797 X 1.281 X .184 HARDENED 25-35 HRC + 1 x O-RING150.00x3.00 N-FPM80					A19517P	
	180							
	250	Not applicable						

Filtration options

Suction filtration – option S

The suction filter is placed in the circuit between the reservoir and the inlet to the charge pump, as shown below.

The use of a filter contamination monitor is recommended.

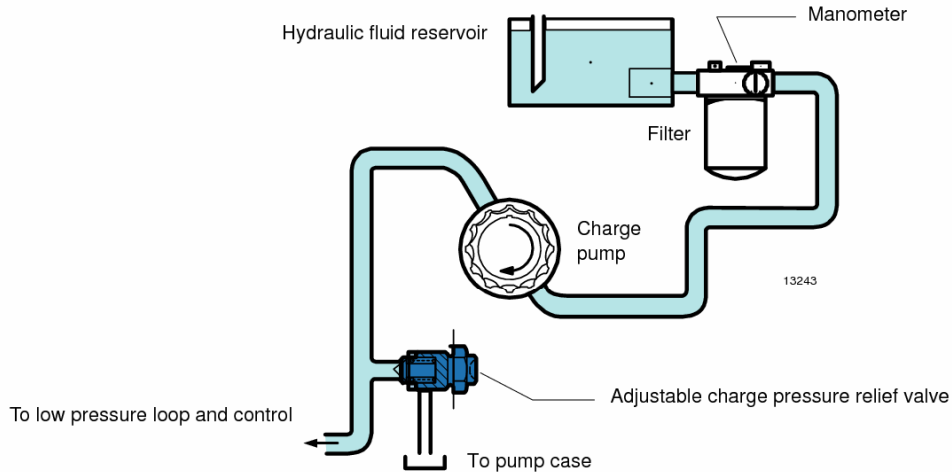

Charge pressure filtration – option R, T, P, and L

The pressure filter can be mounted directly on the pump or mounted remotely for ease of servicing. A 100-125 μm mesh screen, located in the reservoir or the charge inlet line, is recommended when using charge pressure filtration. This system requires a filter capable of withstanding charge pressure.

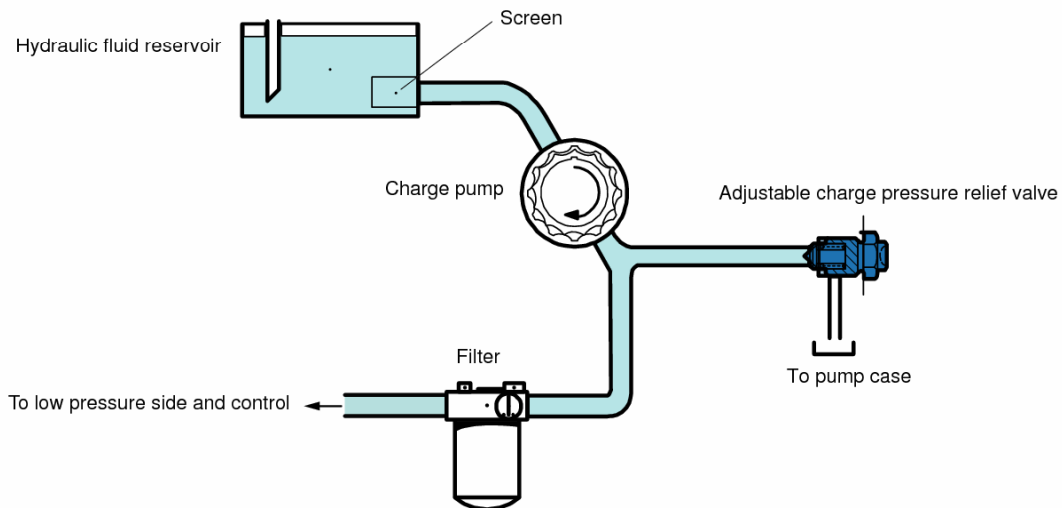

High pressure relief valves

When system pressure exceeds the setting of the valve, it passes oil from the high pressure system loop to the low pressure system loop.

Bypass Function

In some applications it is desirable to bypass fluid around the variable displacement pump when pump shaft rotation is either not possible or not desired. For example, an inoperable vehicle may be moved to a service or repair location or winched onto a trailer without operating the prime mover. To provide for this, P90 pumps are designed with a bypass function.

The bypass is operated by mechanically rotating the bypass hex on both multifunction valves three (3) turns counterclockwise (CCW). This connects working loop A and B and allows fluid to circulate without rotating the pump and prime mover.



Bypass valves are intended for moving a machine or vehicle for very short distances at very slow speeds. They are NOT intended as tow valves.

Speed sensor

An optional speed sensor for direct measurement of speed is available. This sensor may also be used to sense the direction of rotation.

A special magnetic ring is pressed onto the outside diameter of the cylinder block and a Hall effect sensor is located in the housing. The sensor accepts supply voltage and outputs a digital pulse signal in response to the speed of the ring. The output changes its high/low state as the north and south poles of the permanently magnetized speed ring pass by the face of the sensor. The digital signal is generated at frequencies suitable for microprocessor based controls. The sensor is available with M12 connector (4 pins).

Specifications	
P/N	A21674J
Supply voltage*	4.5 to 8.5 VDC
Supply voltage (regulated)	15 VDC max.
Required current	12 mA at 5 VDC, 1 Hz
Max. current	20 mA at 5 VDC, 1 Hz
Max. frequency	15 kHz
Voltage output (high)	Supply -0.5 V min.
Voltage output (low)	0.5 V max.
Temperature range	-40° to 110°C [-40° to 230°F]

* Do not energize the 4.5 to 8.5 VDC sensor with 12 VDC battery voltage. Use a regulated power supply. If you need to energize the sensor with battery voltage, contact your Poclair Hydraulics representative for a special sensor.

	Pulse frequency					
	Frame size					
	055	075	100	130	180	250
Pulse per revolution	52	58	63	69	77	85

M12 connector (4 pins)

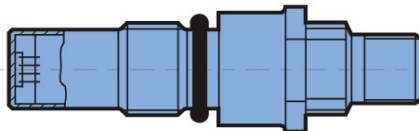

Pin	Function	Colour
1	Supply	Brown
2	NC	White
3	Signal	Blue
4	Ground	black

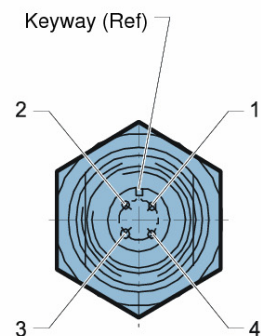

Mating connector	P/N
Cable with right angle M12 connector (length 5 m)	A04999J
Cable with straight M12 connector (length 5 m)	A07468S

Charge Pump

Charge flow is required on all P90 pumps applied in closed circuit installations. The charge pump provides flow to make up internal leakage, maintain a positive pressure in the main circuit, provide flow for cooling and filtration, replace any leakage losses from external valving or auxiliary systems, and to provide flow and pressure for the control system.

Many factors influence the charge flow requirements. These factors include system pressure, pump speed, pump swashplate angle, type of fluid, temperature, size of heat exchanger, length and size of hydraulic lines, control response characteristics, auxiliary flow requirements, hydrostatic motor type, etc.

Unusual application conditions may require a more detailed review of charge pump sizing. Charge pressure must be maintained at a specified level under all operating conditions to prevent damage to the transmission. Poclair Hydraulics recommends testing under actual operating conditions to verify this.

Charge pump sizing/selection

.In most applications a general guideline is that the charge pump displacement should be at least 10% of the total displacement of all components in the system. Unusual application conditions may require a more detailed review of charge flow requirements.

System features and conditions which may invalidate the 10% guideline include (but are not limited to):

- Continuous operation at low input speeds (< 1500 min⁻¹ (rpm))
- High shock loading
- Excessively long system lines (> 3m [9.8 ft])
- Auxiliary flow requirements
- Use of low speed high torque motors

Contact your Poclair Hydraulics representative for application assistance if your application includes any of these conditions.

Available charge pump sizes and speed limits		
Option code	Displacement cm ³ /rev [in ³ /rev]	Rated speed min ⁻¹ (rpm)
B	11 [0.68]	4200
C	14 [0.86]	4200
D	17 [1.03]	3900
E	20 [1.20]	3600
F	26 [1.60]	3300
G	26 [1.60]	3100 (130 cm ³ pump)
H	34 [2.07]	3100
J	47 [2.86]	2600
K	65 [3.96]	2300

Charge pump output flow

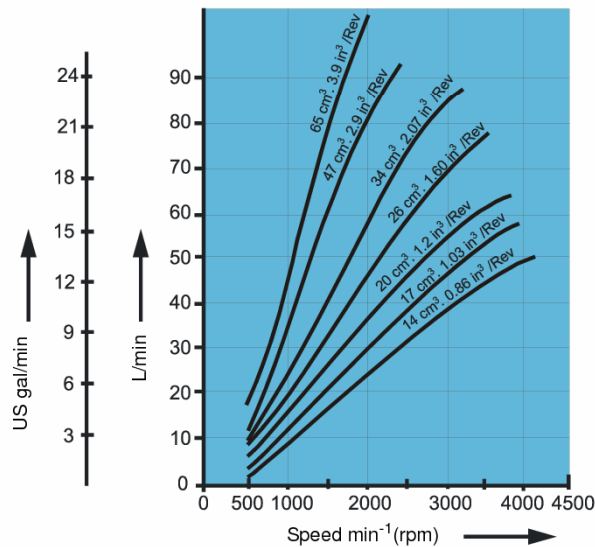

Charge pump power requirements

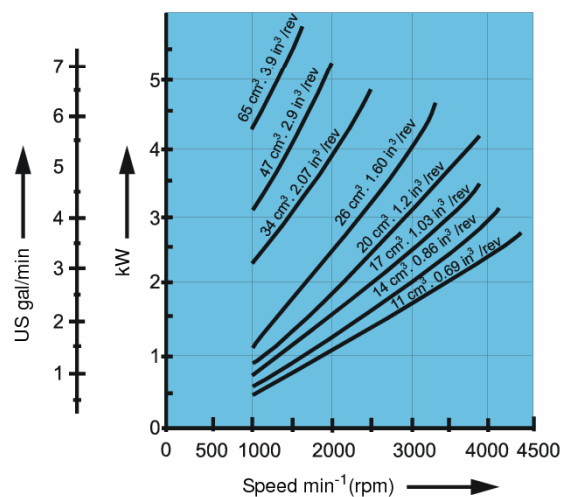

Charge pump flow and power curves

- :Charge pressure: 20 bar [290 PSI]
- :Case drain: 80 °C (8.2 cSt) 180 °F (53 SUS)
- :Reservoir temperature: 70 °C (11 cSt) 160 °F (63 SUS)



Auxiliary Mounting Pads

Auxiliary mounting pads specifications				
Mounting pad size	Option code	Internal spline size	Minimum spline engagement mm [in]	Rated torque N.m [lbf.in]
SAE A	AB	9 teeth 16/32 pitch	13.5 [0.53]	107 [947]
SAE B	BC	13 teeth 16/32 pitch	14.2 [0.56]	256 [2 265]
SAE B-B	BB	15 teeth 16/32 pitch	16.1 [0.63]	347 [3 071]
SAE C	CD	14 teeth 12/24 pitch	18.3 [0.72]	663* [5 868] [†]
SAE D	DE	13 teeth 8/16 pitch	20.8 [0.82]	1 186 [10 500]
SAE D	DG	27 teeth 16/32 pitch	27.0 [1.06]	2 236 [19 790]
SAE E	EF	13 teeth 8/16 pitch	20.8 [0.82]	1 637 [14 489]
SAE E	EG	27 teeth 16/32 pitch	27.0 [1.06]	2 236 [19 790]

* For the 055 pump the rated torque is limited to 445 N.m/[3 830 lbf.in]

Mating pump requirements

The accompanying drawing provides the dimensions for the auxiliary pump mounting flange and shaft.

Pump mounting flanges and shafts with the dimensions noted below are compatible with the auxiliary mounting pads on the P90 pumps.

Auxiliary pump dimensions					
Flange size	Units	P diameter	B maximum	D	F minimum
SAE A	mm [in]	82.5 [3.25]	7.4 [0.29]	32 [1.26]	13.5 [0.53]
SAE B		101.6 [4.00]	10.7 [0.42]	41 [1.61]	14.2 [0.56]
SAE B-B		101.6 [4.00]	10.7 [0.42]	46 [1.81]	16.1 [0.63]
SAE C		127.0 [5.00]	14.3 [0.56]	56 [2.20]	18.3 [0.72]
SAE D		152.4 [6.00]	14.3 [0.56]	75 [2.95]	20.8 [0.82]
SAE E		165.1 [6.50]	18.0 [0.71]	75 [2.95]	20.8 [0.82]
	13 teeth	165.1 [6.50]	18.0 [0.71]	75 [2.95]	27.0 [1.06]
	27 teeth				

Auxiliary pump mounting flange and shaft

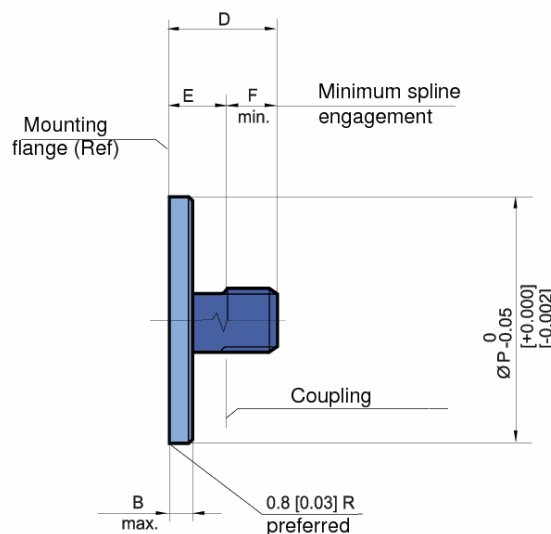

Mounting Flange Loads

Adding tandem mounted auxiliary pumps and/or subjecting pumps to high shock loads may result in excessive loading of the mounting flange. The overhung load moment for multiple pump mounting may be estimated as shown in the accompanying figure.

Overhung load example

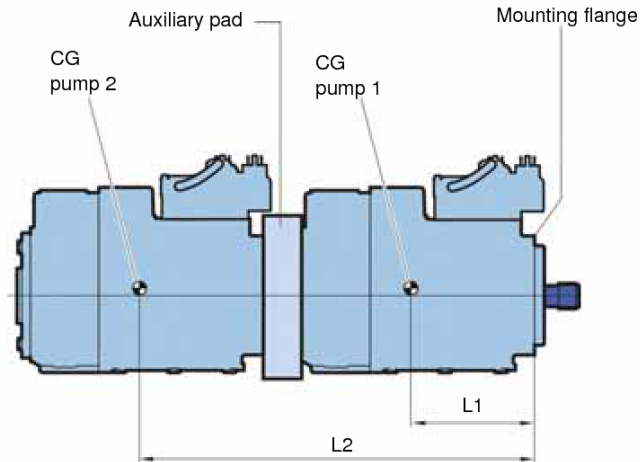

Estimating overhung load moments

W = Weight of pump (kg)

L = Distance from mounting flange to pump center of gravity (m) (refer to pump installation drawings)

$$M_R = G_R (W_1 L_1 + W_2 L_2 + \dots + W_n L_n)$$

$$M_S = G_S (W_1 L_1 + W_2 L_2 + \dots + W_n L_n)$$

Where:

M_R = Rated load moment (N.m)

M_S = Shock load moment (N.m)

G_R = Rated (vibratory) acceleration (G's) * (m/sec²)

G_S = Maximum shock acceleration (G's) * (m/sec²)

* Calculations will be carried out by multiplying the gravity ($g = 9.81 \text{ m/sec}^2$) with a given factor. This factor depends on the application.

Allowable overhung load moment values are shown in the accompanying table. Exceeding these values requires additional pump support.

Allowable overhung load moments		
Frame size	Rated moment (M_R) N.m [lbf.in]	Shock load moment (M_S) N.m [lbf.in]
055	1580 [14 000]	5650 [50 000]
075	1580 [14 000]	5650 [50 000]
100	1580 [14 000]	5650 [50 000]
130	3160 [28 000]	10 730 [95 000]
180	6070 [54 000]	20 600 [182 000]
250	6070 [54 000]	20 600 [182 000]

Integral Pressure Filter (option P and L)

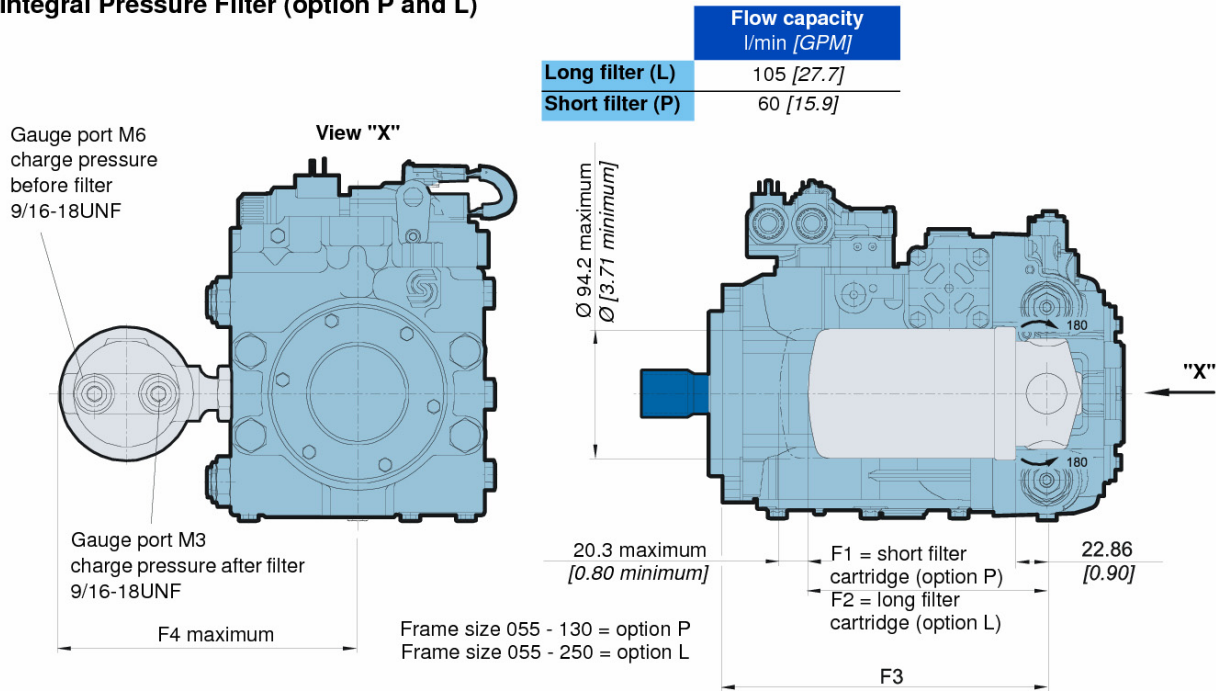

Remote pressure – without filter (option R and T)

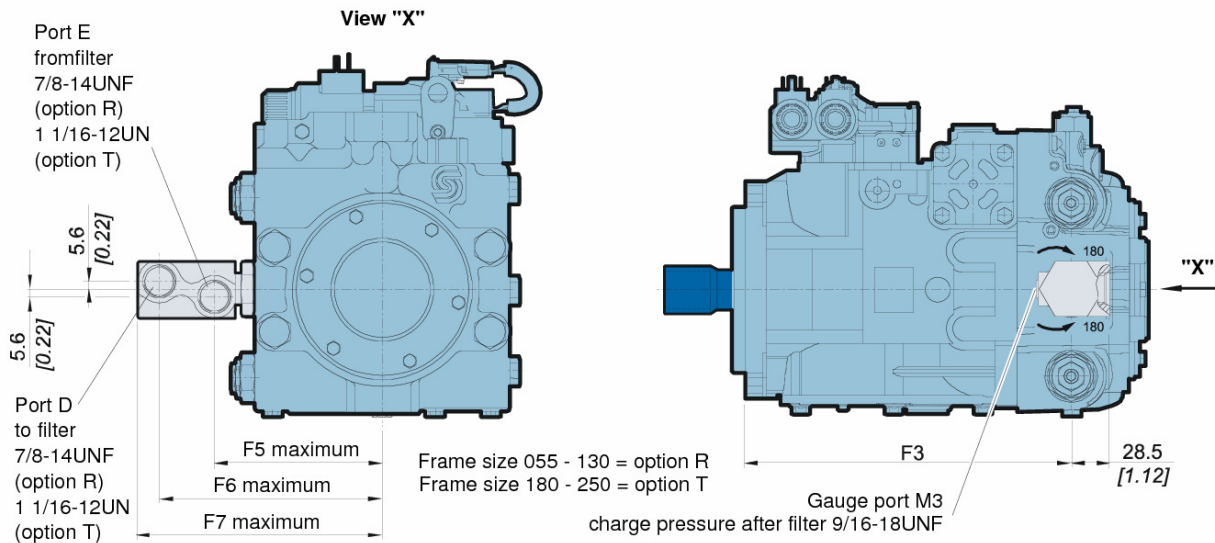

Dimensions mm [in]							
Frame size	F1	F2	F3	F4 max.	F5 max.	F6 max.	F7 max.
055	174.5 [6.87]	262.6 [10.34]	240.9 [8.19]	209.6 [8.25]	114.3 [4.50]	154.3 [6.07]	169.6 [6.68]
075	174.5 [6.87]	262.6 [10.34]	253.2 [9.67]	214.4 [8.44]	119.1 [4.69]	159.1 [6.26]	174.4 [6.86]
100	174.5 [6.87]	262.6 [10.34]	280.7 [11.05]	223.0 [8.78]	127.7 [5.03]	167.7 [6.60]	183.0 [7.20]
130	174.5 [6.87]	262.6 [10.34]	299.9 [11.81]	223.0 [9.17]	137.7 [5.03]	177.7 [6.99]	193.0 [7.60]
180	-	-	327.8 [12.90]	-	182.0 [7.16]	236.8 [9.32]	259.2 [10.2]
250	-	-	342.8 [13.49]	-	182.0 [7.16]	236.8 [9.32]	259.2 [10.2]