



TOP PERFORMANCE COUNTS



TOP PERFORMANCE COUNTS.

Content.

Editorial	3
Series 02	4
Partnership	6
Service Center	7
HPV-02 variable displacement pumps	8
Controls	9
HPR-02 self-regulating pumps	10
SPU noise optimization	11
HMV-02 variable displacement motors	12
Low Speed Concept	13
HMR-02 pressure regulating motors	14
PTO Through-Drive Motors	15
HMF-02 fixed displacement motors	16
GS-02 swing drives	17
VW directional control valves	18
LSC Linde Synchron Control System	19
AK-02 / AH axles	20
MPV-01 / MPR-01 medium pressure pumps	21
Multiple pumps	22
K-02 units	24
LinTronic	26
Electronic controls	27
Peripheral equipment	28
LinDiag®	30
Contact	32



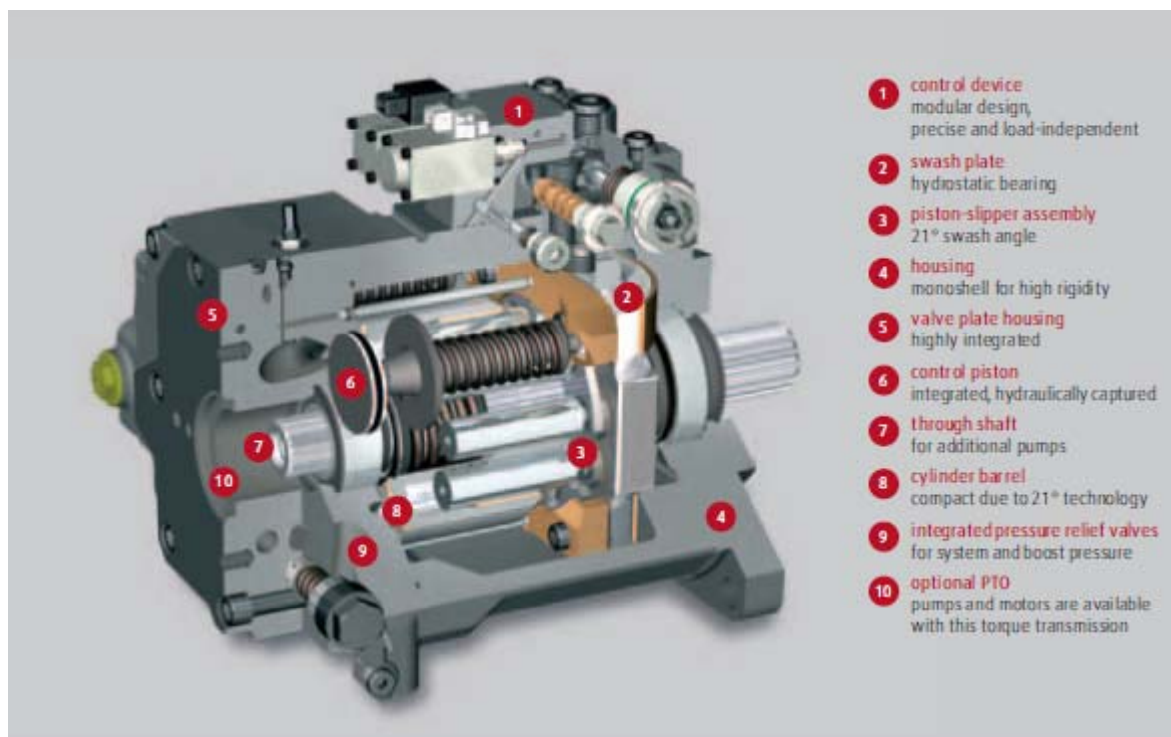

Series 02-Features.

The multiple applications of Linde's Series 02 units are due to its modular design: the combination of a basic unit with the desired control element and interface option allows for an optimum design of your hydraulic system.

Linde's through drive technology for both pumps and motors allows a flexibility of design in a multitude of applications.





High longevity

The hydrostatic bearing of the rotating group compensates for the axial forces. This significantly increases the life expectancy of the unit. The unique material combination of steel on steel assures a high wear resistant piston-slipper assembly hence reliable operation of our long-life units. The swash plate design tolerates high radial accelerations.

Compact design with high power density

All the Series 02 units are based on the 21° technology. The increased piston stroke together with the optimized flow paths give increased efficiency of our rotating groups which transmit more power through smaller build size. Design of rotating group and integrated controlling, regulating and safety functions lead to compact units with a high degree of integration.

Noise reduction

All design features having to do with noise emission, like hydrostatic bearing, commutation, canalling, interfaces and housing shape have been optimized in the Series 02 with regard to pulsation and noise transmission. This helps quite considerably to cut costly noise dampening measures afterwards.

Direct machine control

The machine operator's signals are precisely followed up due to load independent control elements and exact controlling behaviour of the swashplate. Drive commands are carried out on the spot; this makes the machine work responsively and efficiently. Due to the optimized swashplate concept, together with its high level of production quality, smooth starting and jerk-free operation are even possible at low rpm with high torque.

The advanced design of the piston-slipper assembly make the large swash angle of 21° possible. Compact build size and long service life are immediate advantages of this 21° technology.





Partnership. Common success counts.

We are there for you. From initial contact to project engineering and product development all the way through to prototype commissioning and series production. You can rely on our customized solutions for your success.

Partnership is for us an important, indispensable part of product development and quality assurance of Linde Hydraulics.

Therefore, we bring in our knowledge, our experience and our international market position in all phases of customer care. We provide our clients with solutions and accompany them from the initial product idea to the technical release of machines into production. Moreover we give comprehensive training to our customers' personnel, to provide the best transfer of product and system knowledge.

Our sales engineers and technicians support you with enthusiasm and competence in optimizing your hydraulic systems. Any time. Worldwide.

Your advantages

- >> worldwide project support
- >> common product development
- >> specific customer seminars
- >> motivated staff training
- >> customized project coaching
- >> system training for specific applications



The dialogue between client and Linde Hydraulics is the focal point of attention: whether on customer seminars, staff training for our customers or project coaching on Linde hydraulic components and LinTronic – experts on both sides exchange their views. Together for more success in the marketplace.



Service Center. Reliability counts.

Your Reman and Rebuild service. Customer service by Linde Hydraulics. This service program points the way. In providing quick and competent support. Our experienced team of engineers is by your side any time. Best service counts.

By the term customer orientation we, at Linde Hydraulics, understand in particular the service to be available for our customers: worldwide, at any place. With daughter companies in Europe, USA, South America and China together with international representatives we guarantee you reliable competent customer service.

Our sales organization is connected on-line with the central spare parts warehouse in Germany. So you can get original Linde spare parts quickly and simply worldwide.

Our Service Center offers you telephone support as well as on-site trouble shooting and repairs.

Our Service

- >> parts availability within 24 hours
- >> full service maintenance contracts
- >> machine reliability through regular servicing
- >> trouble shooting on site
- >> repair service, also on-site
- >> remanufacturing with "as new" warranty

The Linde Hydraulics Service Center offers their customers reliable remanufacturing and rebuilding service worldwide. Warranty in Linde Quality.





HPV-02. Variable pumps for closed loop operation.

Design characteristics

- >> axial piston pump in swashplate design for high pressure closed loop systems
- >> clockwise or counter clockwise rotation
- >> exact and rugged servo control devices (mechanical, hydraulic, electro-hydraulic)
- >> integrated high pressure relief valves with make-up function
- >> integrated low pressure relief valves for boost, control and cooler circuits
- >> replaceable cartridge filter
- >> SAE high pressure ports
- >> SAE mounting flange with ANSI or SAE spline shaft
- >> through shaft SAE A, B, B-B and C
- >> boost pressure pumps for internal and external suction, integrated cold start relief valve optional
- >> optional tandem and multiple pumps

Controls

- >> M1 mechanical lever
- >> H1 hydraulic pilot
- >> E1 electro-hydraulic
- >> E2 electro-hydraulic with safety function
- >> further control options, e.g. power regulator

maximum pressure control optional

Product advantages

- >> compact design
- >> high power density
- >> dynamic response
- >> high reliability
- >> long service life
- >> noise-optimized
- >> precise and load-independent

HPV-02		55	75	105	135	165	210	280
Max. displacement	cm ³ /rev	54.8	75.9	105	135.6	165	210	280
Permissible speed	rpm	3 300	31 00	29 00	2 700	25 00	2 900	2 000
Max. speed (intermittent)	rpm	3 700	35 00	32 00	2 900	27 00	25 00	2 200
Nominal pressure	bar	420	420	420	420	420	420	420
Peak pressure (intermittent)	bar	500	500	500	500	500	500	500
Continuous input torque	Nm	220	3 05	420	540	660	840	1 115
Max. input torque	Nm	350	485	670	870	1 100	1 400	1 785
Continuous power	kW	75	98	127	153	170	200	254
Max. power	kW	121	157	204	245	275	320	373
Weight with M1 Control (approx.)	kg	42	47	58	72	95	132	158





Controls. Machine control with instinctive feel.

All the controls used in the Series 02 are based on a load-independent control mechanism. No matter which control is used: identical commands always call for the same response in the machine. The sensitive and precise machine control makes work easier and increases productivity. Various customer system options for mechanical, hydraulic and electric input solutions are available. Further special regulating features like torque control and pressure cut-off are also available. The reliable control of the pump can easily be integrated into any kind of vehicle management control system. The electronic input signals for dynamic driving behaviour control the pump independent of pump load condition.

E2 with safety function

Prompt response and steady flow are also characteristic for the E2 control with additional safety function. In this context the electronic control unit compares the travel command to other machine signals. In case of a system fault the electronic control unit will deactivate the „watchdog“-solenoid. Upon this the pump is brought to neutral under full control which ensures that the vehicle is brought to rest in a smooth jerk-free manner, without endangering the driver.

Product advantages of E2

- >> fulfills the high requirements of road traffic admission
- >> minimized susceptibility to interference
- >> with HMF-02: defined swashing back of pump for controlled deceleration and stop in case of system fault
- >> with HMV-02: diesel overspeed protection by fast swashing back of pump





HPR-02. Self-regulating pumps for open loop operation.

Design characteristics

- >> Axial piston pump in swashplate design for high pressure open loop systems
- >> Clockwise or counter clockwise rotation
- >> self-priming at high nominal speed
- >> tank pressurization or swash angle reduction for high speed applications
- >> adaptive noise optimization SPU
- >> decompression fluid is discharged via pump housing to keep suction side calm
- >> exact and rugged load sensing controls
- >> SAE high pressure ports
- >> SAE mounting flange with ANSI or SAE spline shaft
- >> through shaft SAE A, B, B-B and C
- >> optional tandem and multiple pumps

Regulator types

- >> LP Load sensing with hydraulic pressure cut-off
- >> ETL Load sensing with electrical override
- >> TL Load sensing with mechanical power limiter

Product advantages

- >> optimum interaction with Linde LSC control valves and LinTronic

- >> energy saving operation by "flow on demand"-control
- >> dynamic response
- >> excellent suction up to rated speed
- >> noise optimization over the whole range of operation
- >> compact design
- >> high power density
- >> high reliability
- >> long working life

HPR-02		55	75	105	135	210	2x 105
Max. displacement	cm ³ /rev	54.8	75.9	105	135.6	210	2x 105
Continuous rated speed <small>with pressure</small>	rpm	2700	2600	2900	2900	2000	2900
Max. oil flow	l/min	147.9	197.3	241.5	311.9	420	483
Nominal pressure	bar	420	420	420	420	420	420
Peak pressure (intermittent)	bar	500	500	500	500	500	500
Continuous input torque	Nm	220	305	420	540	836	650
Max. input torque	Nm	368	508	702	907	1404	1090
Continuous power	kW	60	80	100	130	175	156
Max. power	kW	95	130	160	207	280	262
Weight (approx.)	kg	39	39	50	65	116	107





SPU. Noise optimization by commutation.

Legal emission regulations force manufacturers of mobile machinery to optimize the noise emission of their products. Since secondary measures tend to be expensive and less efficient Linde prefers to fight the noise where it is generated: by optimally connecting an additional volume directly next to the commutation of the HPR-02 pump, Linde Hydraulics invented the SPU silencer. The adaptive SPU reduces flow and pressure pulsations in the regulating pump over the entire range of operation – without loss of power. Compared to a customary variable pump, an HPR-02 with SPU reduces pulsation level by up to 70%, independently of pressure, speed and temperature! The pulsations transmitted to system components and machine structure are significantly less, making the machine quieter.

Product advantages

- » low noise level inside the cabin and outside: obvious relief for driver and environment
- » self-adapting wide scale reduction of pulsation over the whole range of operation: independent of pressure, speed and temperature
- » no need of costly measures for additional noise dampening
- » significantly reduced noise peaks
- » no affect on function and performance
- » minor increase of weight and mounting space
- » simple and robust design
- » immediately usable, maintenance-free

Noise optimization by Linde Hydraulics. Obvious advantage for driver and environment: Less noise not only relieves the driver in the cabin, but also construction workers and residents.





HMV-02.

Variable displacement motors for closed and open loop operation.

Design characteristics

- >> axial piston motor or in wash plate design for high pressure closed and open loop systems
- >> optimized starting and low speed behaviour
- >> purge valves for circuit and case flushing optional
- >> stepless or 2-position control
- >> electric or hydraulic controls
- >> superposed pressure control optional
- >> brake pressure shut-off optional
- >> swashing to 0 cc/rev
- >> high pressure relief valves available
- >> through shaft with free shaft end or with coupling flange
- >> SAE high pressure ports radial or axial
- >> SAE mounting flange with ANSI or SAE spline shaft
- >> plug-in version optional
- >> speed sens or optional
- >> double motor available

Controls

- >> H1 hydraulic stepless
- >> H2 hydraulic 2-position
- >> H4 hydraulic stepless $V_{min}=0$ cc/rev
- >> E1 electro-hydraulic stepless
- >> E2 electro hydraulic 2-position
- >> E4 electro hydraulic stepless $V_{min}=0$ cc/rev
- >> E6 as E4 with inverted shifting

Product advantages

- >> jerk-free low speed
- >> high starting torque
- >> large conversion range
- >> zero angle possible
- >> dynamic response
- >> PTO Through-Drive Motor
- >> compact design
- >> high power density
- >> high reliability
- >> long service life

HMV-02		55	75	105	135	165	210	280
Max. displacement	cm ³ /rev	54,8	75,9	105	135,6	165	210	280
Max. operating speed at V_{max}	rpm	4100	3800	3500	3200	3100	2700	2400
Max. speed (intermittent) at V_{min}	rpm	5300	5000	4700	4000	3900	3500	3200
Nominal pressure	bar	420	420	420	420	420	420	420
Peak pressure (intermittent)	bar	500	500	500	500	500	500	500
Continuous output torque	Nm	218	302	418	540	657	836	1114
Max. output torque	Nm	366	508	702	907	1104	1404	1872
Continuous power	kW	94	120	153	181	213	236	280
Max. power	kW	157	202	257	304	358	397	470
Weight (approx.)	kg	28	32	42	56	76	101	146





Low Speed Concept. Precision by innovative drive system.

Standard hydraulic motors at low speeds in their starting phase cannot generate the necessary torque. Therefore, the power of the fast spinning hydraulic motors has to be reduced by means of several step gearboxes down to the speed needed on the wheel. Somewhat higher windage losses and poorer mechanical efficiency are benevolently accepted in this context.

Quite the opposite holds true for the motors by Linde Hydraulics:

The motors of the Series 02 are capable of transmitting the required torque even at low speed and make it possible to start smoothly and sensitively. Therefore, additional gear ratios for rpm reduction are not necessary.

Product advantages

- >> jerk-free and steady low speed behaviour
- >> fuel saving in all operating situations
- >> elimination of mechanical gearboxes
- >> quieter through speed reduction
- >> less maintenance because of simplified drive concept
- >> increased service life of the transmission

Hydraulic motors by Linde Hydraulics with optimized low speed properties make it possible to apply a smooth and uninterrupted road cover. Linde technology provided on a smooth level.





HMR-02. Variable motors for open and closed loop operation.

Design characteristics

- >> axial piston motor in swash plate design for high pressure open and closed loop systems
- >> optimized starting and low speed behaviour
- >> purge valves for circuit and case flushing in closed loop optional
- >> internal system pressure control, no external piping required
- >> brake pressure shut off for closed loop
- >> high pressure relief valves available
- >> through shaft with free shaft end or with coupling flange
- >> SAE high pressure connection ports radial or axial
- >> SAE mounting flange with ANSI or SAE spline shaft
- >> plug-in version optional
- >> speed sensor optional
- >> counter balance valve optional

Maximum displacement override

- >> pneumatic
- >> hydraulic (high and low pressure)
- >> electric

Product advantages

- >> steady low speed behaviour
- >> high starting torque
- >> large conversion range
- >> PTO Through-Drive Motor
- >> compact design
- >> high power density
- >> high reliability
- >> long service life
- >> dynamic response

HMR-02		55	75	105	135	165	210
Max. displacement	cm ³ /rev	54.8	75.9	105	135.6	165	210
Max. operating speed at Vmax	rpm	4100	3800	3500	3200	3100	2700
Max. speed (intermittent) at Vmin	rpm	5300	5000	4700	4000	3900	3500
Nominal pressure	bar	420	420	420	420	420	420
Peak pressure (intermittent)	bar	500	500	500	500	500	500
Continuous output torque	Nm	218	302	418	540	657	836
Max. output torque	Nm	366	508	702	907	1104	1404
Continuous power	kW	94	120	153	181	213	236
Max. power	kW	157	202	257	304	358	397
Weight (approx.)	kg	28	32	42	56	76	101





PTO Through-Drive Motors. Breakthrough in drive system design.

In conventional drives the torque of the hydraulic motor can be transmitted to the cardan shaft only by means of a dropbox. For further optimization of the drive train Linde Hydraulics developed the PTO Through-Drive Motor. Based on the standard hydraulic motor of the Series 02 with just one shaft end, the PTO Through-Drive Motor offers two shaft ends to transmit the torque.

Hence the machine designer can conceive the hydraulic motor to fit directly and immediately into the drive train thus saving mounting space. The dropbox usually needed in a conventional propulsion drive can be saved. This reduces both noise emission and fabrication cost of the entire vehicle while overall efficiency increases.

Product advantages

- >> dropbox eliminated
- >> more installation space
- >> optimized drive concept
- >> low maintenance transmission
- >> reduced noise
- >> increased drawbar pull
- >> fuel saving
- >> ideal drive solution for municipal vehicles, wheeled loaders, telescopic handlers, and forest machines

Compact machines call for compact drive solutions. Less is more. The new PTO Through-Drive Motor. The compact drive solution for more installation space and increased efficiency.





HMF-02.

Fixed displacement motors for open and closed loop applications.

Design characteristics

- >> axial piston motor in washplate design for high pressure open and closed loop systems
- >> optimized starting and low speed behaviour
- >> purge valves for circuit and case flushing optional
- >> high pressure relief valves set fixed or variable optional
- >> SAE high pressure ports radial or axial
- >> SAE mounting flange with ANSI or SAE spline shaft

Additional functions integrated for swing and winch drives

- >> directional control valve function swing
- >> torque control function
- >> high pressure relief valves with controllable characteristic
- >> priority function
- >> secondary relief combined with make up function
- >> discharge function

Product advantages

- >> steady low speed
- >> high starting torque
- >> compact design
- >> high power density
- >> high reliability
- >> long service life

HMF-02		28	35	50	75	105	135
Max. displacement	cm ³ /rev	28.6	35.6	51.3	75.9	105	135.6
Max. operating speed	rpm	4500	4500	4100	3800	3500	3200
Max. speed (intermittent)	rpm	4800	4800	4400	4100	3800	3500
Nominal pressure	bar	420	420	420	420	420	420
Peak pressure (intermittent)	bar	500	500	500	500	500	500
Continuous output torque	Nm	112	139	204	298	418	537
Max. output torque	Nm	187	234	327	502	702	903
Continuous power	kW	54	67	88	120	153	181
Max. power	kW	96	120	141	202	257	304
Weight (approx.)	kg	16	16	19	26	33	39





GS-02. Swing drives for open loop operation.

Design characteristics

- >> integrated fixed displacement hydraulic motor HMF-02, low speed, large displacement
- >> planetary gearbox
- >> multiple disc brake, hydraulically released
- >> hydraulic motor, gear box and brake in one common housing
- >> integrated valving for combined rpm and torque regulation
- >> anti-reaction plate
- >> pinion with tapered roller bearings

Product advantages

- >> direct mounting onto plate
- >> adjustable coasting
- >> steady running at low speeds
- >> high starting torque
- >> compact size
- >> torsional stiffness
- >> high power density
- >> high reliability
- >> long service life
- >> high dynamics
- >> efficient, low noise
- >> small gear clearance

Optional

- >> flanged-on load sensing directional control valve block, with integrated priority and torque control function
- >> speed sensor
- >> integrated secondary relief set fixed or variable combined with make up function

GS-02		900	1200	1600	2000	2500	3000	3500
Max. pinion speed	rpm	100	100	100	100	100	100	100
Nominal pressure	bar	250	250	250	250	250	250	250
Peak pressure (intermittent)	bar	280	280	280	280	280	280	280
Pinion torque at 1250 bar	Nm	3600	4600	6500	7800	9800	11200	13800
Weight (approx.)	kg	120	128	169	206	213	220	290



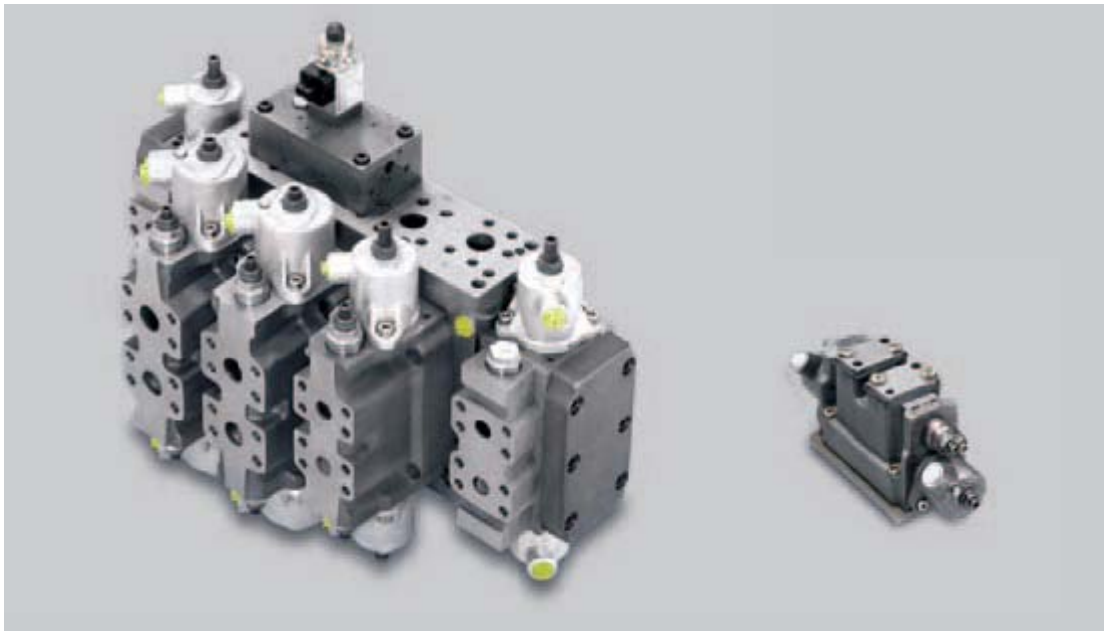

VW. Directional control valves for open loop operation.

Design characteristics

- >> closed centre load sensing directional control valves in spool design
- >> hydraulic or electric proportional control
- >> monoblock or single valve design
- >> extension of valve blocks possible by single valves
- >> horizontal and vertical installation
- >> valves can be mounted directly onto the actuator
- >> SAE high pressure ports

Integrated functions

- >> Fine mode
- >> priority selection
- >> pressure limitation for load sensing and regulating pump
- >> step-up function
- >> torque control function
- >> load holding function
- >> lowering throttles
- >> make up
- >> anti-cavitation security by adjustable return line
- >> regeneration function
- >> automatic air bleed valve
- >> float function

Product advantages

- >> excellent control with all flows
- >> load independent
- >> precision metering
- >> dynamic response for fast working cycles
- >> energy saving
- >> integral
- >> simple sensitive operation
- >> high reliability
- >> long service life

WW		14	18	25
Output	l/min	150	250	400
Nominal pressure	bar	350	350	350
Peak pressure (intermittent)	bar	420	420	420





LSC Linde Synchron Control – System. Intelligent distribution of fluid.

The Linde Synchron Control System, in open loop circuits, converts the commands of the machine driver into direct signals to the actuators. The easy control of all components supports efficient fatigue-free working. Simultaneous load-independent movements and a pump control "on demand" are preconditions for fast working cycles with at the same time low operation cost. Safety and optimum exploitation of the machine are, apart from power regulation and high pressure relief, provided by the optional priority selection. Even with synchronous control of several functions the priority mode guarantees preferential operation of predominant actuators.

Product advantages

- >> system can be individually adapted to customer specifications
- >> supply to additional actuators is optional
- >> simple system control
- >> adjustable power limiter
- >> fast response pressure cut off
- >> simultaneous motion of several actuators without reciprocal or with defined influence
- >> excellent sensitivity
- >> valve plate with optimized single valves
- >> electronic override feasible
- >> low fatigue working

LSC stands for high handling performance due to load-independent and sensitive machine conduct. Fast and direct.





AK-02 / AH. Compact axle AK-02. Hydraulic axles AH.

Design characteristics

>> rigid self-contained hydraulic axle

On both sides:

- >> fixed displacement motor HMF-02
- >> multiple disc brake, hydraulically released
- >> subsequent mechanical reduction gear
- >> wheel bearing

Product advantages

- >> high starting torque
- >> steady low speed behaviour
- >> torsional stiffness
- >> high power density
- >> high reliability
- >> long service life

Integration of the variable displacement pump into the AK 30-02 provides further advantages:

- >> compact design
- >> high degree of integration
- >> short response time
- >> precise control

The compact axle AK 30-02 has integrated the variable pump HPV 105-02, boost and working pump as well as the drive control.

		AK 30-02	AH20	AH45
Nominal size hydro-pump HPV-02	cm ³ /rev	105		
Max. axle load	kg	7400	4786	9600
Max. wheel torque	Nm	3300	1744	5532
Weight (approx.)	kg	282	178	336





MPV-01/ MPR-01 variable and regulating pumps. For closed and open loop applications.

Design characteristics

- >> axial piston pump in swashplate design for medium pressure closed and open loop systems
- >> clockwise or counter clockwise rotation available
- >> compact design
- >> SAE two bolt flange with ANSI spline shaft
- >> through shaft SAE A, B and B-B
- >> tandem and multiple pumps optional

MPV

- >> for closed loop
- >> variety of servo controls
- >> integrated boost pressure pump
- >> high pressure relief and make-up valves
- >> boost pressure relief valve

Controls

- >> M1 mechanical lever
- >> H1 hydraulic pilot
- >> E1 electro-hydraulic

MPR

- >> for open loop
- >> load sensing regulator (LS)
- >> max pressure regulator
- >> rpm increase possible by tank pressurization

MPV-01		45	63
Max. displacement	cm ³ /rev	46	63
Permissible speed	rpm	3800	3500
Nominal pressure	bar	300	300
Peak pressure (intermittent)	bar	350	350
Oil flow at n max	l/min	175	221
Input torque at Vmax and p max	Nm	219	301
Max. power	kW	87	110
Weight (approx.)	kg	27	39

MPR-01		28	45	71
Displacement	cm ³ /rev	28	45	71
Continuous rated speed w/o pressurizing	rpm	3000	2600	2200
Nominal pressure	bar	280	280	280
Peak pressure (intermittent)	bar	350	350	350
Max. oil flow at n max	l/min	84	117	156
Input torque at Vmax	Nm	125	200	316
Max. power	kW	39	55	73
Weight (approx.)	kg	15	21	33





Multiple pumps. For open and closed loop operation.

Double, tandem and multiple pumps can be obtained by combining our variable and regulating pumps, so that either larger flows can be made available or different circuits can be served.

Double pumps: two pumps of identical rated size fitted back to back on one common port head for feeding one circuit

Tandem and multiple pumps: two or more pumps fitted in series, so that even different circuits can be fed. Nominal size and type (for open or closed loop) are in this context variable. Selection is allowable up to the maximum transmittable torque.

Product advantages

- ✦ just one drive shaft required
- ✦ no need for splitter box for the pumps
- ✦ compact design
- ✦ individual control of each single pump
- ✦ no adverse influence on functionality of the single rotating groups
- ✦ advantages like high dynamics and precise control remain in full



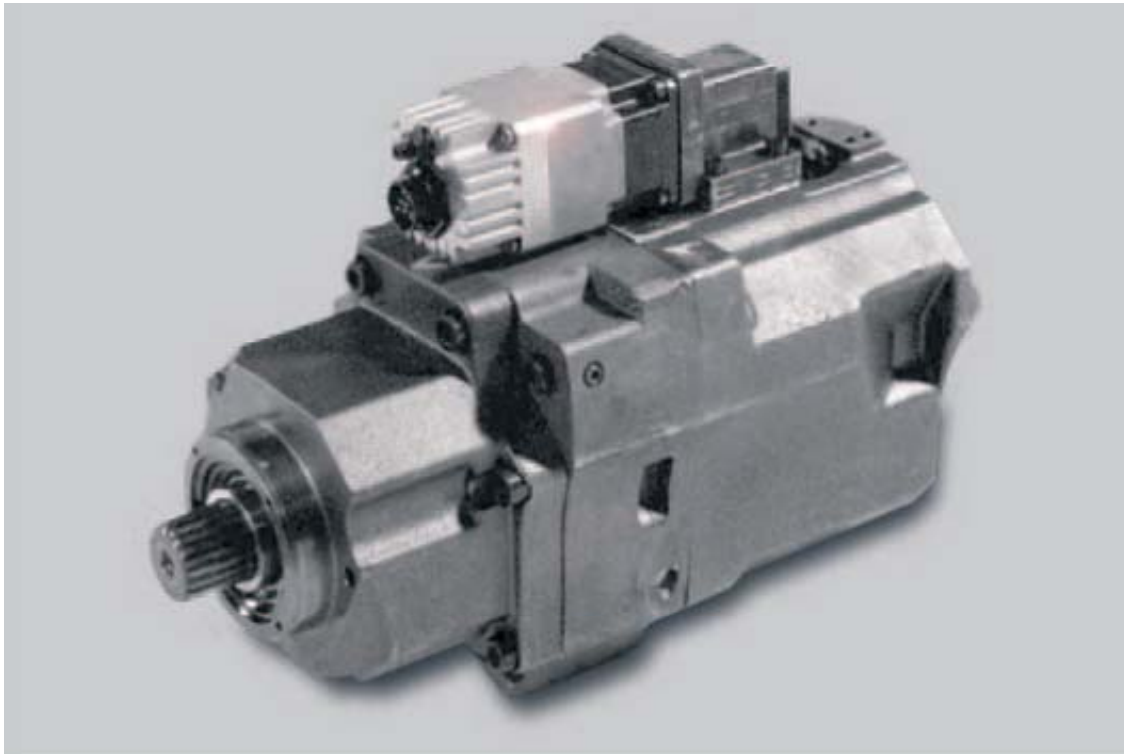

K-02 units.

Together with the customer Linde Hydraulics defines new standards of technology.

Advanced modular drive technology, realised in hydrostatic variators for stepless transmissions, form the core of power split drives.

With customer-specific developments Linde Hydraulics supports the change from power shift to stepless technology.





K-02 units. Stepless for optimum performance.

Design characteristics

- >> variable displacement pump HPV-02 and fixed displacement motor HMF-02 back-to-back in one common housing
- >> conceived for power split gear boxes
- >> integrated high pressure relief valves with boost and discharge function
- >> external boost
- >> electric or hydraulic pump control
- >> customized housing geometry

Product advantages

- >> accurate control of gear box
- >> exact gear shift without interrupting tractive effort
- >> dynamic response
- >> sensitive start-up
- >> precise crawling speed
- >> high efficiency
- >> low fuel consumption over entire operating range
- >> compact design
- >> high reliability
- >> long service life

Precise transmission control for simple operation without interrupting tractive effort. From stand still to maximum speed. Stepless.





LinTronic.

Electronic controls of the LinTronic Program take advantage of the most modern CAN-Bus technology. In conjunction with Linde hydraulic components and peripheral equipment the electronic control units CEB, CED and CEP offer an optimum vehicle management in mobile hydraulics for the most diversified fields of application. By choosing economical modes of operation and increased user-friendliness they provide better exploitation of performance and at the same time reduce emissions.





Electronic Controls. For open and closed loop applications.

1. CEB

Electronic control for open loop hydraulic systems with load sensing and diesel throttle control.

2. CED

Electronic control for hydrostatic drives in closed or open loop or in mixed systems. The combination of pump control E2 with CED fulfills the high safety demands of the German road traffic regulation (TÜV).

3. CEP

Electronic control for one-track or two-track drives in closed or open loop applications. Drive and steering function can be controlled by joysticks or pedals.

Product advantages

- >> Series 02 units work together in an optimized manner
- >> high availability and reliability
- >> safety on a high level by parallel supervising controller
- >> management of the entire drive system, using just one electronic control with additional optional switch and proportional outputs
- >> driver relief by automatic power regulation to the prevailing operating situation
- >> digital rpm regulation for accurate control in high and low idle speed
- >> individually adjustable drive behaviour
- >> simple set up and diagnostics by means of LinDiag®





LinTronic. Peripheral equipment.

1. Joystick, electronic CEH 71

2-way / 4-way electronic control stick, longitudinal axis with brake, transverse axis spring centered, additional switch function in handle; this product is suited for console mounting.

2. Joystick LLC

Potentiometer joystick, stabilized voltage supply 5 V-15 V, spring-centered, suitable for armrest mounting, various versions, e.g. single lever, 4 quadrant version available.

3. Throttle / inch pedal CEH 20

Drive pedal or inch pedal (inverse characteristic curve) for reduction of reference value, stabilized supply voltage 5 V-15 V, robust die cast console.

4. Diesel throttle control CHX 01

Electro hydraulic linear actuator (cylinder, stroke 25 mm) for altering the injection pump, suited for mounting on the engine/injection pump, vibration proof, preferably for PWM signal input.





LinTronic. Peripheral equipment.

5. Potentiometer CEH 05

Redundant potentiometer for mounting on a throttle pedal with return spring, stabilized supply voltage 5 V-15 V.

6. Potentiometer CEH 04

Suitable for direct mounting onto diesel engine / injection pump for throttle position feed back, metal housing, vibration proof.

7. Speed sensor CEH 10

Speed sensor for hydraulic motor or gear. Two channels for detection of rotational direction. Hall-sensor up to 15 kHz, pressure resistant to 5 bar static.

8. Pressure sensor CEH 50

For high pressure detection, pressure range 0-600 bar, analogue output signal 1 V-5 V, stabilized supply voltage 12 V-30 V.





LinDiag®.

Software for set up and diagnostics.

Characteristics

- >> compatible with Linde Hydraulics electronic controls
- >> suited for PC/laptop with Windows operating system with serial or USB interface
- >> operated by mouse, key or pad
- >> diagnostics
- >> documentation and reporting
- >> harness checking
- >> parameterization
- >> "Teach in" of components
- >> data logger
- >> electronic box restorable to factory setting

Product advantages

- >> optimum system usage by teach-in function
- >> error prevention through continual comparison and documentation of the variance
- >> user-friendly software up-dating ("Flashing")
- >> easy usage by self-explanatory user surface
- >> large letters and buttons offer optimum use even with the machine running
- >> self-adapting screen size
- >> multi-lingual, up to 10 languages can be programmed
- >> documentation exportable into MS Office
- >> practical-minded partition of control elements by functional groups
- >> modular set-up: individual functions can be added optionally later

