



# CHECK VALVES



## VP-NOV. VALVES.

### CHECK VALVES



#### DIRECT OPERATED VALVES

Check valve VP-NV (NG 6, 10)

5

5

Direct operated valves



#### PILOT OPERATED VALVES

Check valve NOV-... -E (NG 6, 10)  
Check valve NOV-6-D (NG 6)  
Check valve VP-NOV (NG 6, 10)

9

9

11

13

Pilot operated valves



#### COUNTERBALANCE VALVES

Check-Q-meter BZV (NG 6)  
Check-Q-meter modular valve VP-BZV (NG 6)

17

17

21

Counterbalance valves

## CHECK VALVE VP-NV

- NG 6, 10
- Up to 350 bar [5 076 PSI]
- Up to 60 l/min [26,4 GPM]
- Connecting dimensions to ISO 4401.
- For vertical stacking - sandwich plate design.
- Free hydraulic fluid flow in one direction.



VP-NV-6, VP-NV-10

### Operation

Check valves type VP-NV permit the hydraulic fluid flow in one direction, with a tight-off in the opposite direction. Sandwich plate design - for vertical stacking. These valves consist of a housing (1), poppet (2), and a spring (3). A poppet valve can be fitted into the line P, T, A or B. It serves for shutting off the hydraulic fluid flow in one direction, permitting a free flow in the opposite direction. This is made possible by the poppet (2) which provides positive seating. The hydraulic fluid flow under cracking pressure 0,4 bar [5.8 PSI] causes the poppet to lift, thus freeing the flow. In the opposite direction, the spring (3) pushes the poppet (2) against the seat, shutting the hydraulic fluid flow off.

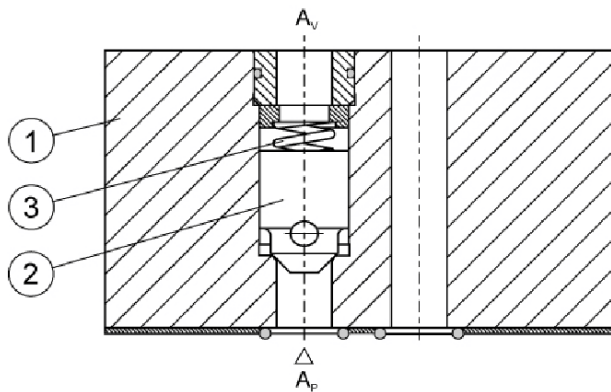

### Hydraulic symbols

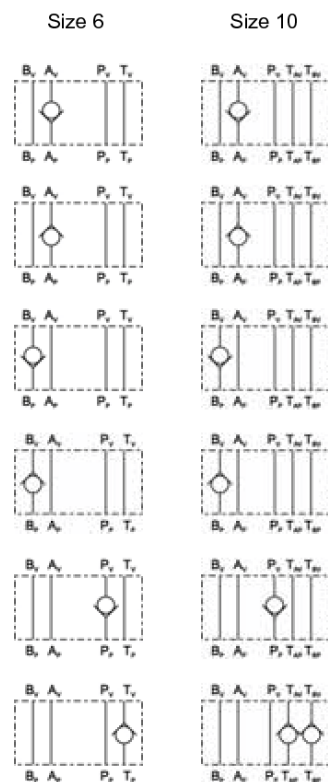

### Features

Size		6	10
Flow rate	l/min [GPM]	50 [13.2]	100 [26.4]
Flow velocity	m/s	4	
Operating pressure	Bar [PSI]	350 [5 076]	
Cracking pressure	Bar [PSI]	0,4 [5.8]	
Oil temperature range	°C [°F]	-20 to +70 [-4 to +158]	
Viscosity range	mm <sup>2</sup> /s [SUS]	15 to 380 [69,5 to 1.760]	
Filtration	NAS 1638	8	
Mass	kg [lbs]	0,87 [1.91]	2,77 [6.10]

**ΔP-Q Performance curves**

Measured at 50C [122F]  
and viscosity of 32 mm<sup>2</sup>/s [148 SUS].

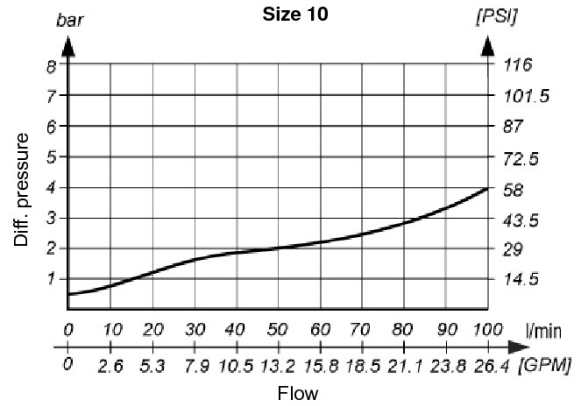
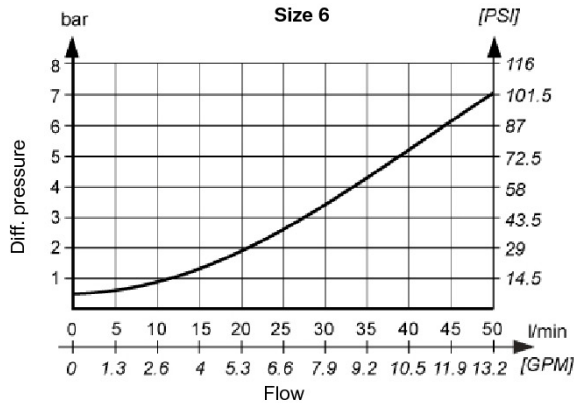

**Dimensions**

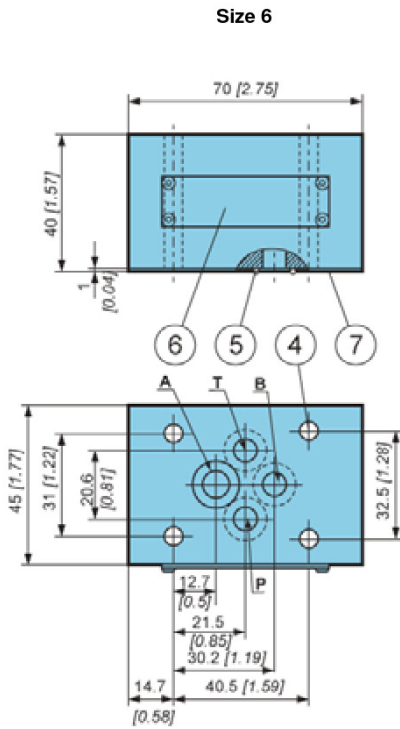

- 4. Bores for fixing screws M5
- 5. O-ring 9,25x1,78
- 6. Nameplate
- 7. O-ring plate

Required quality of the mating surface

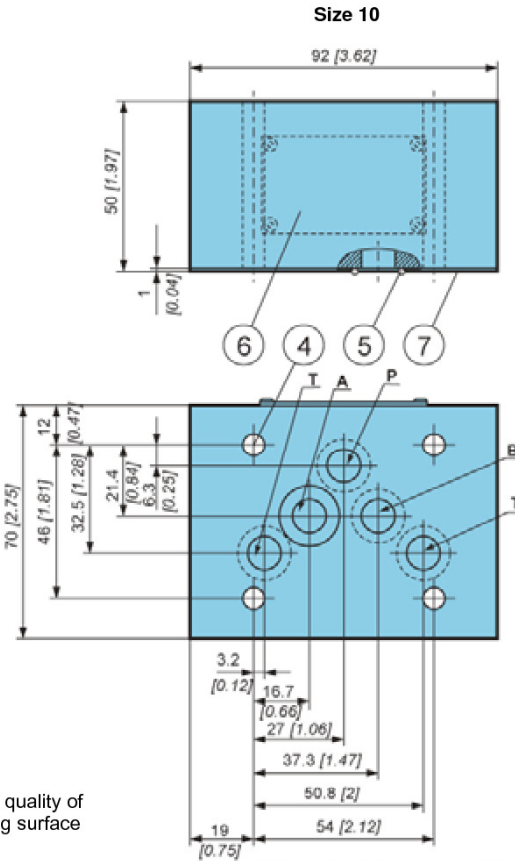
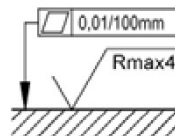

- 4. Bores for fixing screws M6
- 5. O-ring 12,42x1,78
- 6. Nameplate
- 7. O-ring plate

**Model code**



**Size**

Size 6	6
Size 10	10

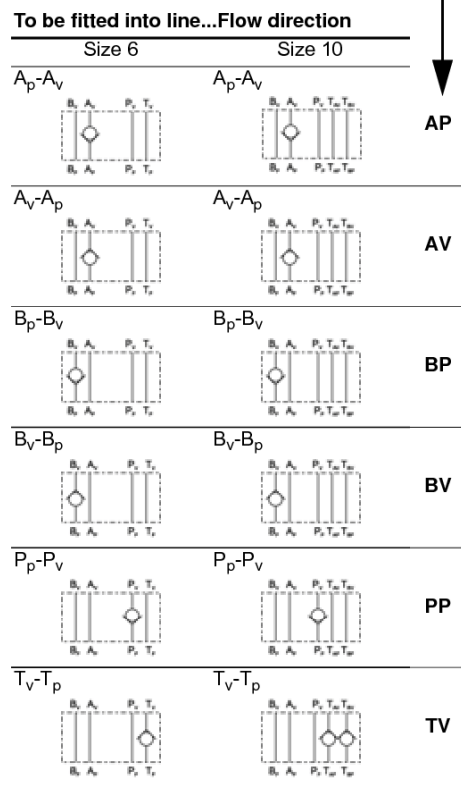

**Seals type**

NBR seals for mineral oil HL,HLP to DIN 51524	No designation
FPM seals for HETG, HEES, HEPG to VDMA 24568 and ISO 15380	E

Special requirements to be briefly specified

## CHECK VALVE NOV-...-E

- NG 6, 10
- Up to 350 bar [5 076 PSI]
- Up to 50 l/min [13.2 GPM]
- Threaded connections to ISO 1179 (BSPP/Gas), ISO 11926 (UNF).
- Flow shut-off in one service line.
- Direct in-line mounting.



NOV-6-E; NOV-10-E

### Operation

Pilot operated check valves type NOV enable the hydraulic fluid flow in the service lines to be automatically shut-off and made free, respectively.

Free flow direction is from the valve port B to port A. In the opposite direction is blocked for the hydraulic fluid flow. Free flow from port A to port B is achieved by means of pressure in port Z.

To assure zero leakage there is necessary to discharge ports B and Z towards T in the zero position of the directional valve.

### Hydraulic symbol

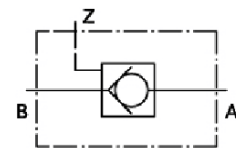

### Features

Size		6	10
Flow rate	l/min [GPM]	35 [9.2]	50 [13.2]
Operating pressure	Bar [PSI]	350 [5 076]	
Cracking pressure (B-A)	Bar [PSI]	0.5 [7.2]	
Area ratio		1:4	
Oil temperature range	°C [°F]	-20 to +70 [-4 to +158]	
Viscosity range	mm <sup>2</sup> /s [SUS]	15 to 380 [69,5 to 1.760]	
Filtration	NAS 1638	8	
Mass	kg [lbs]	0,5 [1.10]	0,65 [1.43]

### ΔP-Q Performance curves

Δp - Q Performance curves of the flow in direction A → B (check valve pilot opened).

Measured at 50°C [122°F]  
and viscosity of 32 mm<sup>2</sup>/s [148 SUS].

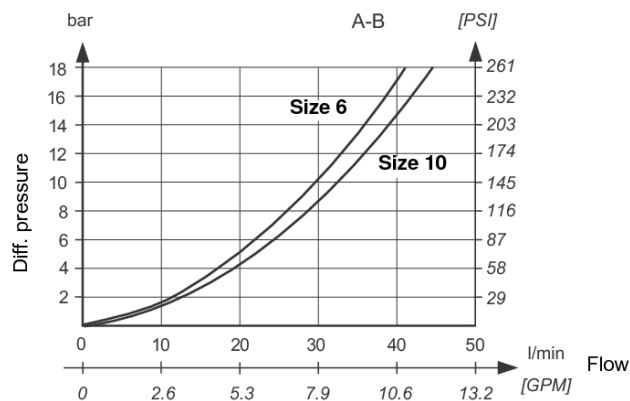

**Dimensions**

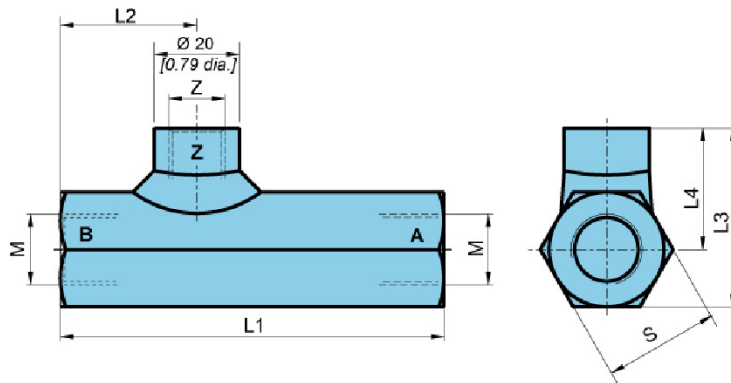

Size	6	10
L1	90 [3.54]	94 [3.70]
L2	32 [1.26]	34 [1.34]
L3	42 [1.65]	45 [1.77]
L4	28,5 [1.12]	30 [1.18]
S	27 [1.06]	30 [1.18]
M	G3/8	G1/2
Z	G1/4	G1/4

**Model code**

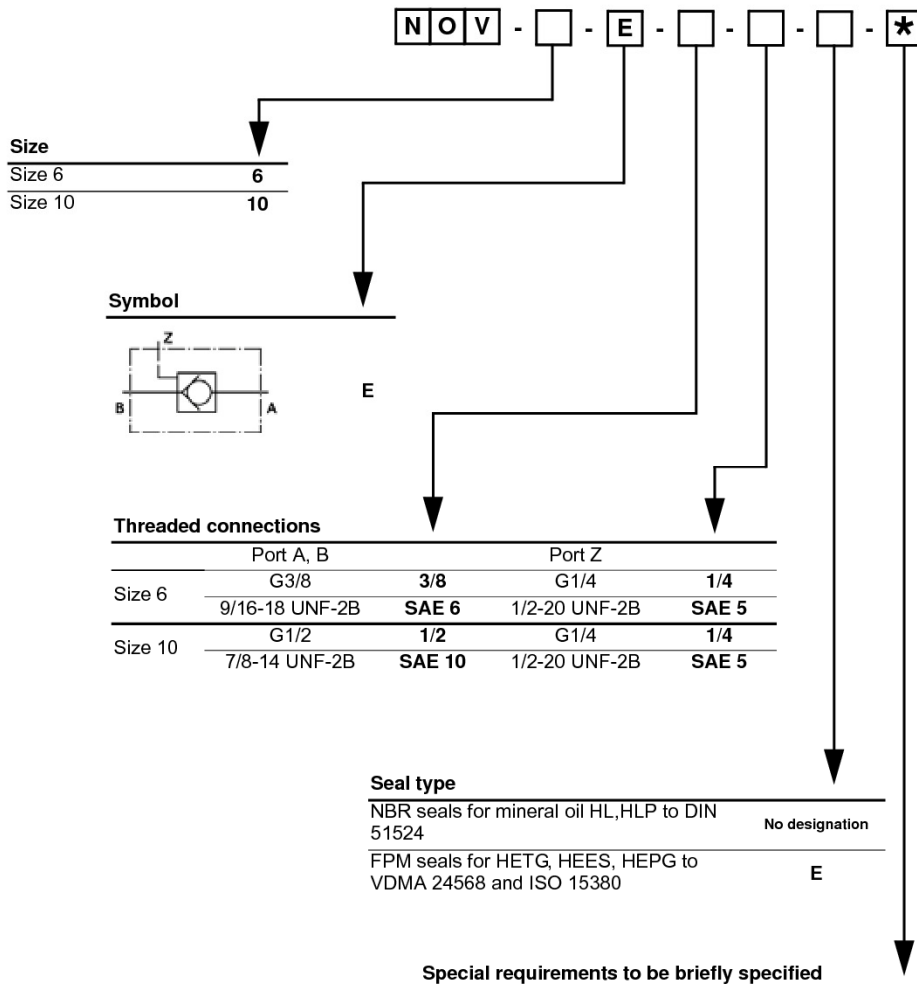

## CHECK VALVE NOV-6-D

- NG 6
- Up to 350 bar [5 076 PSI]
- Up to 60 l/min [15.8 GPM]
- Threaded connections to ISO 1179 (BSPP/Gas), ISO 11926 (UNF).
- Flow shut-off in one service line.
- Direct in-line mounting.



NOV-6-D

### Operation

Direct operated check valves type NOV enable the hydraulic fluid flow in the service lines to be automatically shut-off and made free, respectively.

Free flow direction is always from the valve side A1, B1 to side A2, B2. In the opposite direction is the valve blocked for the hydraulic fluid flow. Free flow in port A in direction A2 to A1 is achieved by means of pressure in port B, and vice versa.

To assure zero leakage there is necessary to discharge ports A1 and B1 towards T in the zero position of the directional valve.

### Hydraulic symbol

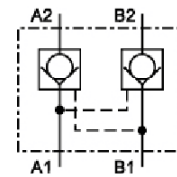

### Features

Size	6	
Flow rate	l/min [GPM]	60 [15.8]
Operating pressure	Bar [PSI]	350 [5 076]
Cracking pressure	Bar [PSI]	1 [14.5]
Area ratio		1:3,9
Oil temperature range	°C [°F]	-20 to +70 [-4 to +158]
Viscosity range	mm <sup>2</sup> /s [SUS]	15 to 380 [69,5 to 1.760]
Filtration	NAS 1638	8
Mass	kg [lbs]	1,5 [3.30]

### ΔP-Q Performance curves

Δp - Q Performance curves of the flow in direction A1, B1 → A2, B2 (through check valve) and in direction A2, B2 → A1, B1 (check valve pilot opened).

Measured at 50°C [122°F] and viscosity of 32 mm<sup>2</sup>/s [148 SUS].

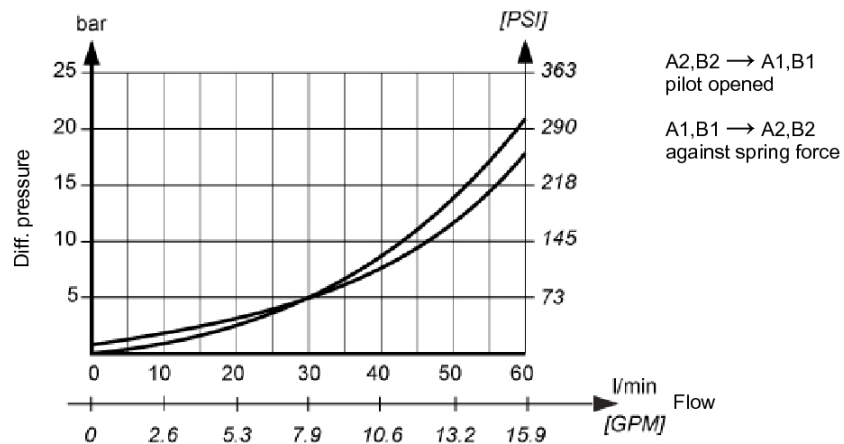

**Dimensions**

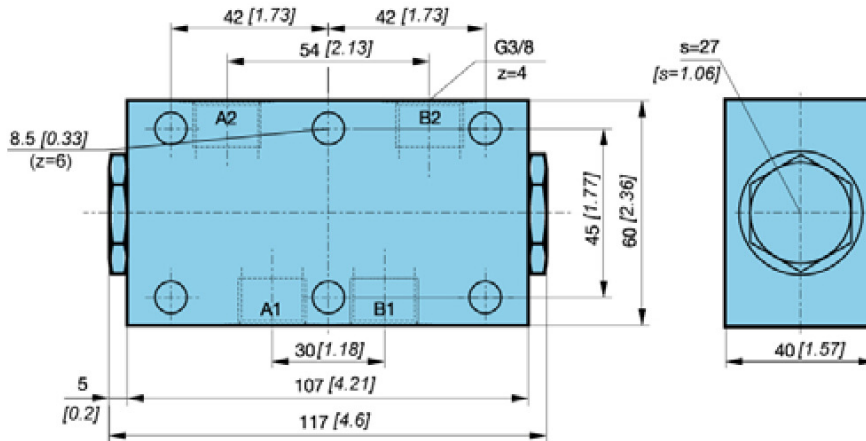

**Model code**

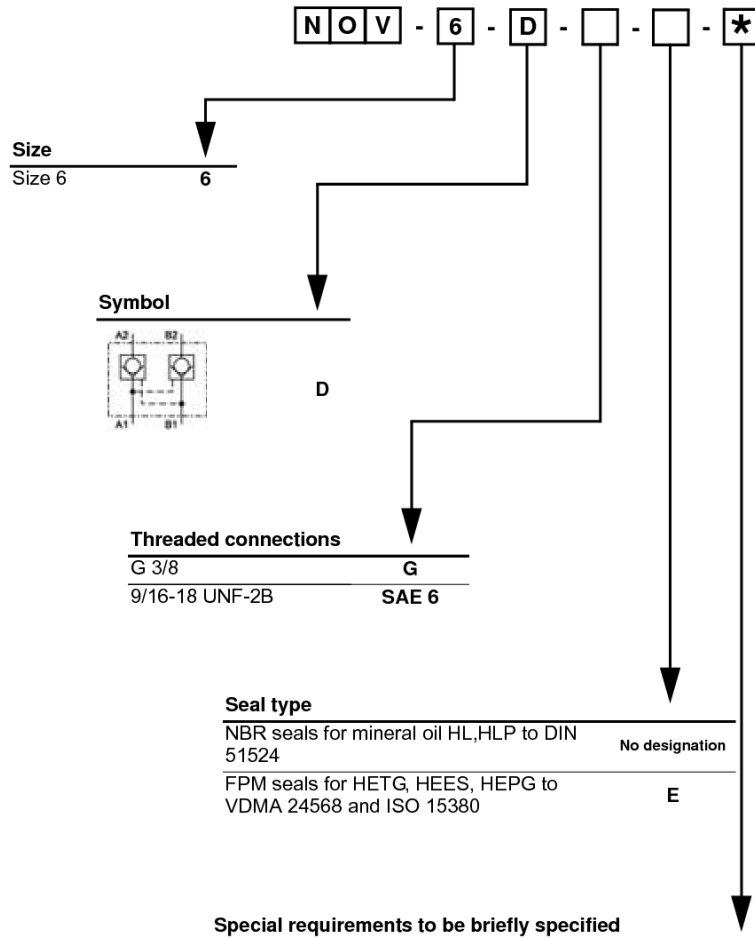

## CHECK VALVE VP-NOV

- NG 6, 10
- Up to 350 bar [5 076 PSI]
- Up to 60 l/min [26,4 GPM]
- Connecting dimensions to ISO 4401.
- Flow shut-off in both or one service line.
- For vertical stacking - sandwich plate design.
- Height and width of the valves to ISO 7790 norms.



VP-NOV-10-..., VP-NOV-6-..

### Operation

Pilot operated check valves type VP-NOV enable the hydraulic fluid flow in the service lines to be automatically shut off and made free, respectively.

Free flow direction is always from the valve side "V" to the subplate side "P". In the opposite direction is the valve blocked for the hydraulic fluid flow. Free flow in port A in direction P to V is achieved by means of pressure in port B, and vice versa.

To assure zero leakage there is necessary to discharge ports A and B towards T in the zero position of the directional valve.

### Hydraulic symbols

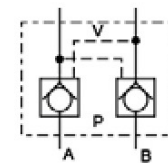
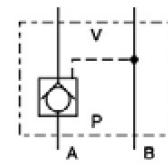
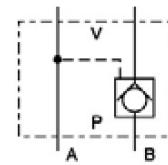

### Features

Size		6	10
Flow rate	l/min [GPM]	60 [15.8]	100 [26.4]
Operating pressure	Bar [PSI]	350 [5 076]	
Cracking pressure	bar [PSI]	1 [14.5]	0,5 [7.2]
Area ratio		1:3,9	1:3,6
Oil temperature range	°C [°F]	-20 to +70 [-4 to +158]	
Viscosity range	mm <sup>2</sup> /s [SUS]	15 to 380 [69,5 to 1.760]	
Filtration	NAS 1638	8	
Mass	kg [lbs]	1,8 [3.9]	3,5 [7.7]

### Mounting example

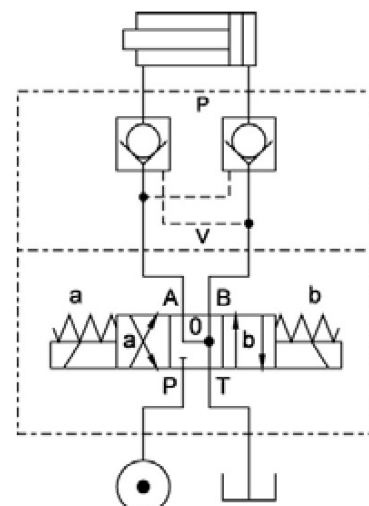



**ΔP-Q Performance curves**

Δp - Q Performance curves of the flow in direction V to P (through check valve) and in direction P to V (check valve pilot opened with  $p_x = 80$  bar).

Measured at 50C [122F] and viscosity of 32 mm<sup>2</sup>/s [148 SUS].

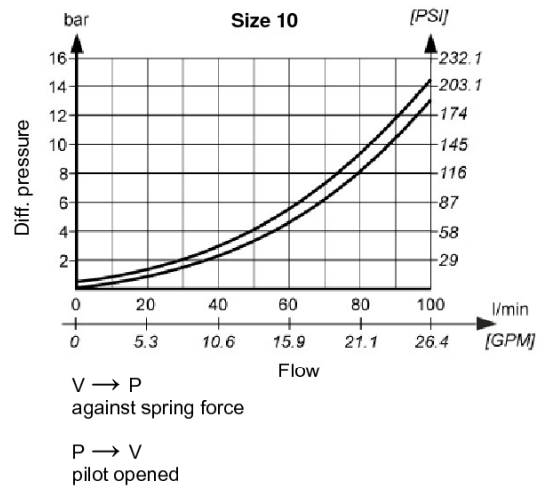
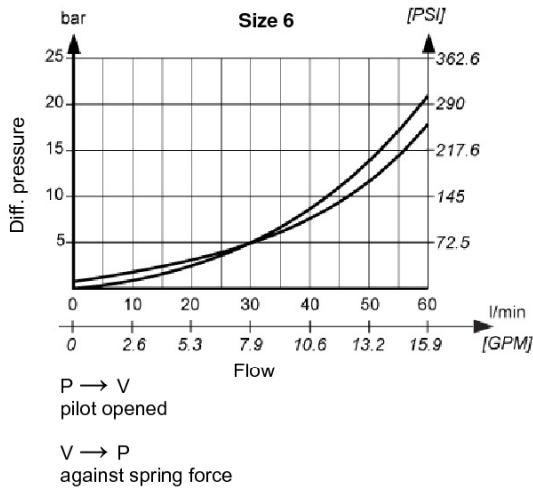

**Model code**

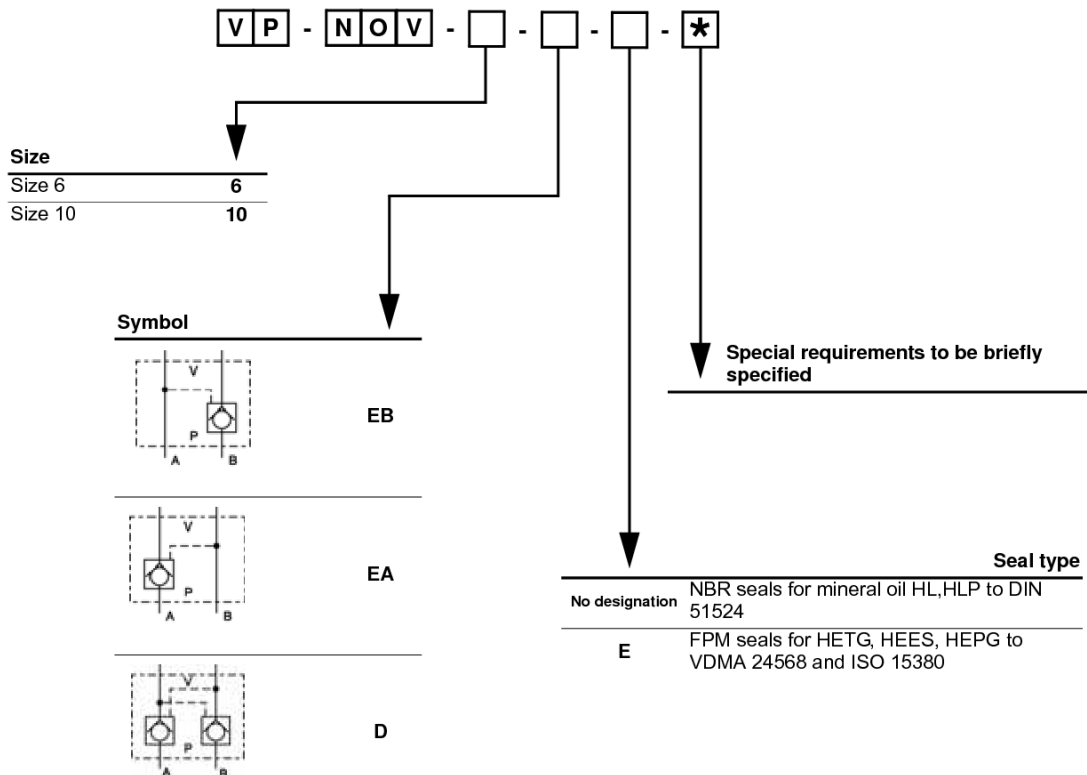

## CHECK-Q-METER BZV

- NG 6
- Up to 350 bar [5 076 PSI]
- Up to 60 l/min [15.8 GPM]
- Hermetically sealing at closed flow path.
- Minimum pressure losses when the medium flows from port A towards port B.
- When the medium flows from port B towards port A the speed of load lowering is controlled with respect to the medium flow rate supplied to the opposite side of the hydraulic motor or cylinder. With operating cylinders the characteristic ratio of surface areas must be taken into account.
- For building into pipe-lines.
- Threaded connections to ISO 9974 (Metrisch), ISO 1179 (BSPP/Gas), ISO 11926 (UNF).



**BZV-6-D, BZV-6-E**

### Operation

The check-Q-meter is used for maintaining constant speed during the lowering of loads by means of hydraulic cylinders or hydromotors in the systems where load changes with time. It prevents uncontrolled falling of load if defects occur in the pipeline between the directional control valve and the check-Q-meter or if there is no pilot pressure. When it is installed in combination with a directional control valve with negative change-over in intermediate positions, it has the function of a holding valve. If the load on hydraulic cylinders or hydromotors does not change the sign, a single check-Q-meter must be used. The check-Q-meter consists of a housing (1), main poppet (2), auxiliary spool (3), pilot poppet (4), spring (5), insert housing (7) and setting screw (8).

#### Lifting the load:

The hydraulic fluid flows from port A towards port B with minimum pressure losses, the main poppet (2) being lifted. In the case of a pressure drop and an interruption in the hydraulic fluid supply to port A, the main poppet (2) closes, holding the load in position. With the directional control valve in position (a) the hydraulic fluid flows to the annulus side of the hydraulic cylinder, which provokes a certain pilot pressure on the auxiliary spool (3). The check-Q-meter opens and thereby a free hydraulic fluid flow from port B towards port A occurs, when the main poppet (2) leans against the insert housing (7), where as the auxiliary spool (3) still performs a part of the controlled move which depends on the quantity of the hydraulic fluid supplied in a unit of time to the annulus side of the operating cylinder. In the opening direction, also the load pressure works on the circle of the predefined surface. The pilot pressure required for the opening of the check-Q-meter is:

$$\text{Required pilot pressure} = \frac{\text{safety valve setting} - \text{load pressure}}{4,25}$$

In case that the hydraulic cylinder piston starts to move faster than permitted by the hydraulic fluid supply, the pilot pressure on the port X drops and the auxiliary spool (3) under the effect of spring (5) moves in the valve closing and shutting-off direction, respectively.

Because of the reduction in flow cross-section the resistances increase, which causes an increase in the pilot pressure and thereby a larger opening of the check-Q-meter. In this manner, the check-Q-meter is continuously balanced during lowering. The spring (5) setting force must be set at least 1.3 -times higher than the maximum force due to the operating pressure (pressure due to load):

$$\text{Max. operating pressure} = \frac{350 \text{ Bar [5076 PSI]}}{1,3} = 270 \text{ Bar [3916 PSI]}$$

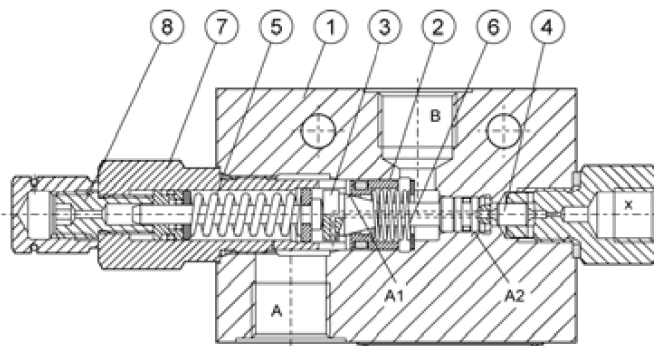

### Hydraulic symbols

BZV-6-E

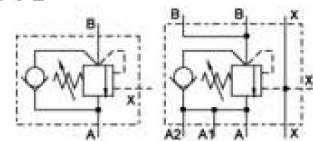

BZV-6-D

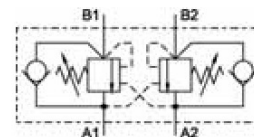

### Mounting example

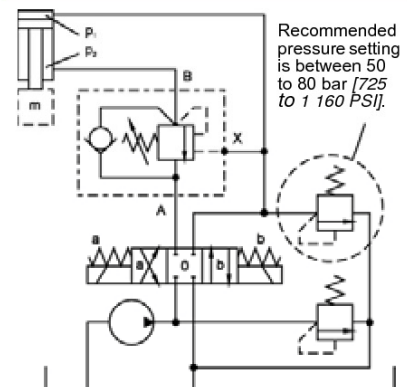

Because of the multiplication of pressure in hydraulic cylinder by the difference of surface areas:

$$p_2 = p_m + p_1 \times \varphi \quad \varphi = A_1/A_2 > 1$$

It is recommended to protect the circuit by means of a pressure relief valve, the cracking pressure of which is set with respect to the selected spring (5) in the BZV.

**Features**

Size		BZV-6-E	BZV-6-D
Flow rate	l/min [GPM]		60 [15.8]
Operating pressure	spring 200 Bar [2.900 PSI]	Bar [PSI]	150 [2 175]
	spring 350 Bar [5076 PSI]		270 [3 916]
Pilot pressure	spring 200 Bar [2.900 PSI]	Bar [PSI]	4 to 50 [58 to 725]
	spring 350 Bar [5076 PSI]		6 to 85 [87 to 1.232]
Cracking pressure	Bar [PSI]		2,2 [31.9]
Pilot ratio	R = A2/A1-A2		4,25
Oil temperature range	°C [°F]		-20 to +70 [-4 to +158]
Viscosity range	mm <sup>2</sup> /s [SUS]		15 to 380 [69,5 to 1.760]
Filtration	NAS 1638		8
Mass	kg [lbs]	1,5 [3.30]	2,4 [5.29]

**ΔP-Q Performance curves**

Measured at 50C [122F] and viscosity of 32 mm<sup>2</sup>/s [148 SUS].

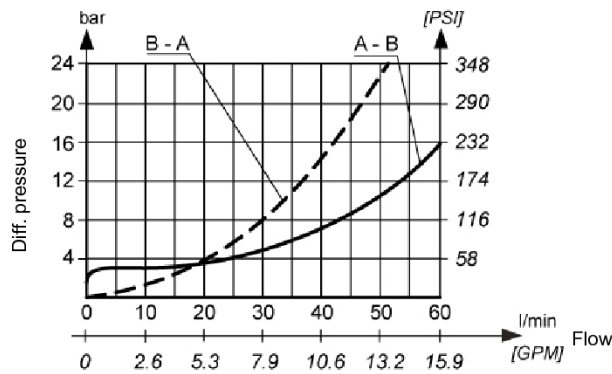

**Dimensions**

BZV-6-E-...-C

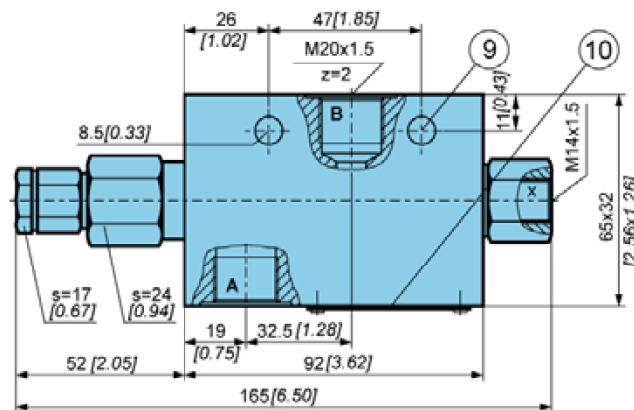

9. Fixing screw  
10. Nameplate

**Dimensions**

**BZV-6-D-...-C**

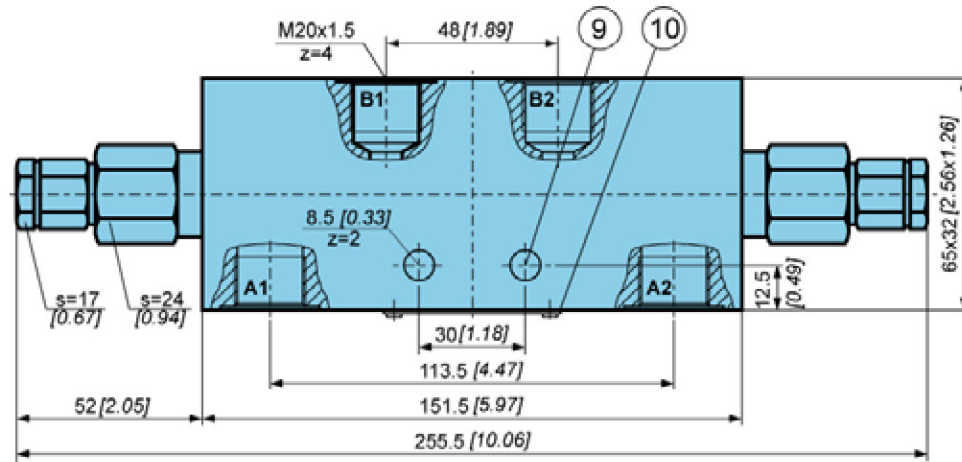

9. Fixing screw  
10. Nameplate

**BZV-6-E-...-CG**

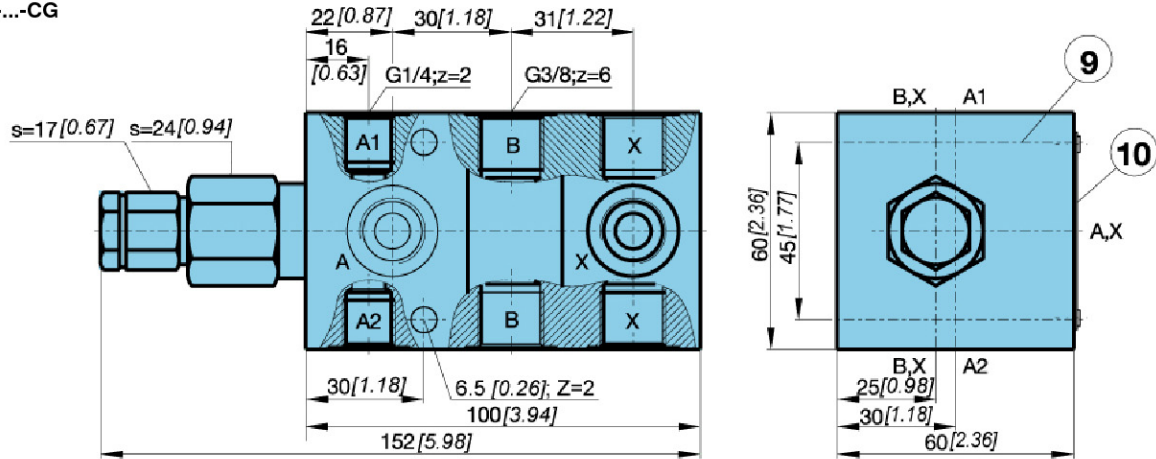

9. Fixing screw  
10. Nameplate

**BZV-6-E-...-CDG**

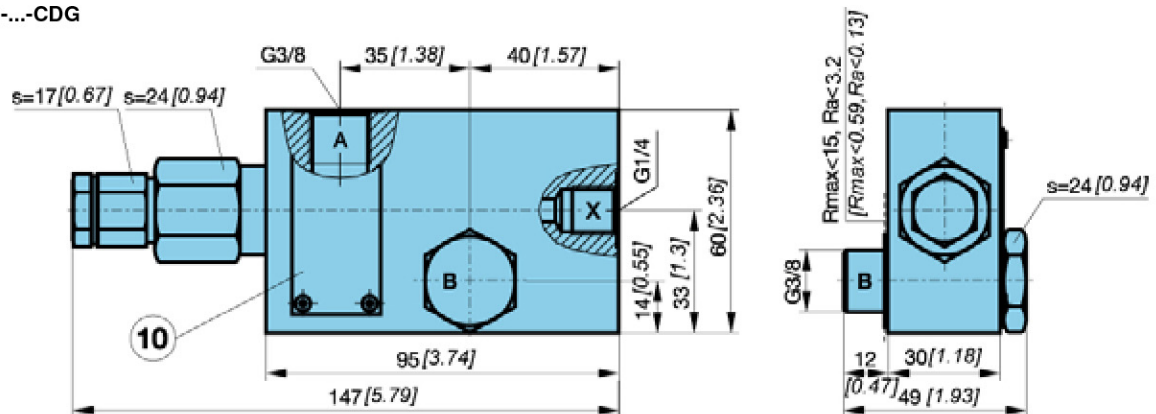

10. Nameplate

**Model code**

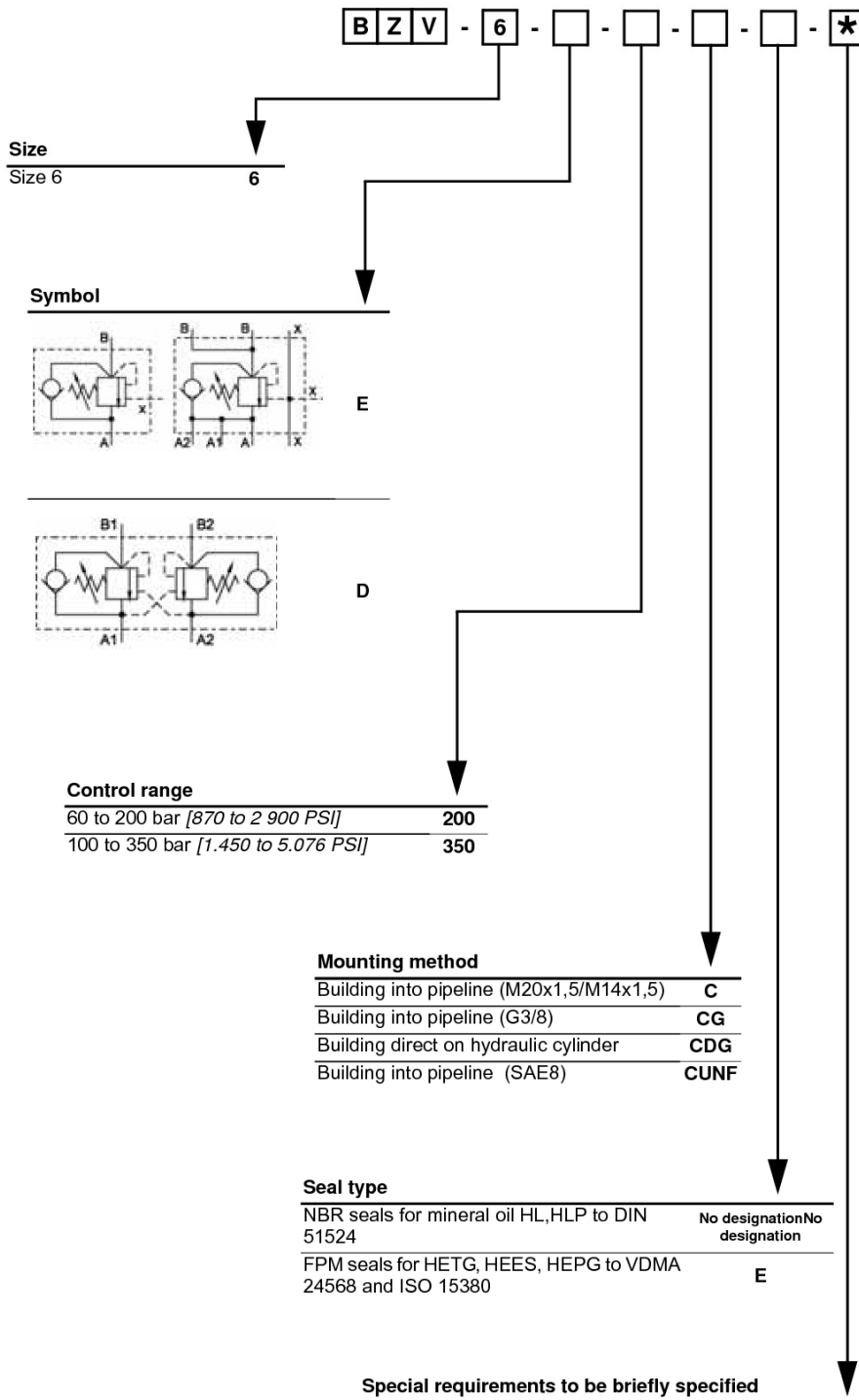

## CHECK-Q-METER MODULAR VALVE VP-BZV

- NG 6
- Up to 350 bar [5 076 PSI]
- Up to 60 l/min [15.8 GPM]
- Connecting dimensions to ISO 4401.
- Modular plate design for vertical stacking.
- Height and width of the valve according to ISO 7790.



VP-BZV-6

### Operation

Modular check-Q-meter valve in combination with other stacking elements gives static and dynamic load control by regulating the flow into and out of hydraulic actuators. It prevents load uncontrol run away and allows thermal expansion relief of the hydraulic fluid. Flow in line B (A) from side P to V is induced when the required pilot pressure in line A (B) is induced. For stable valve function the valve must be set ( $P_s$ ) at least 1.3 - times higher than maximum expected load pressure ( $P_L$ ).

$$\text{Required pilot pressure (P}_R\text{)} = \frac{\text{Counterbalance valve setting (P}_s\text{) - load pressure (P}_L\text{)}}{\text{Pilot ratio (R)}}$$

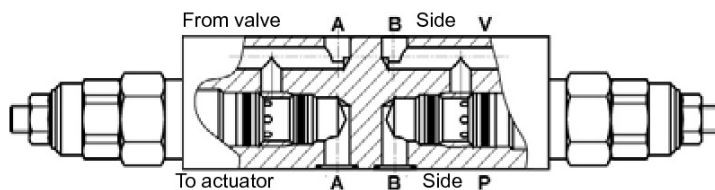

### Hydraulic symbol

### Mounting example

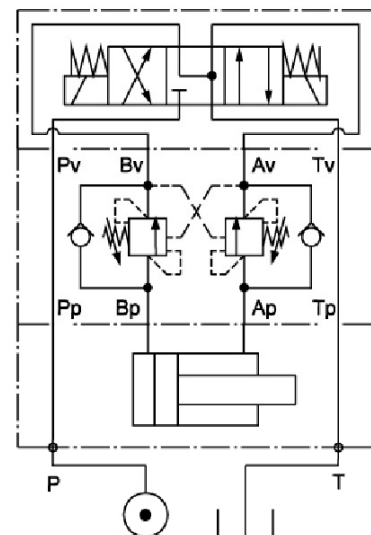

### Features

Size		6 (single valve)	6 (double valve)
Flow rate	l/min [GPM]		30 [7.9]
Operating pressure	Bar [PSI]		270 [3 916]
Cracking pressure	Bar [PSI]		1 [14.5]
Oil temperature range	°C [°F]		-20 to +70 [-4 to +158]
Viscosity range	mm <sup>2</sup> /s [SUS]		15 to 380 [69,5 to 1.760]
Filtration	NAS 1638		8
Mass	kg [lbs]	1,3 [2.9]	1,8 [4.00]

**ΔP-Q Performance curves**

Measured at 50C [122F]  
and viscosity of 32 mm<sup>2</sup>/s [148 SUS].

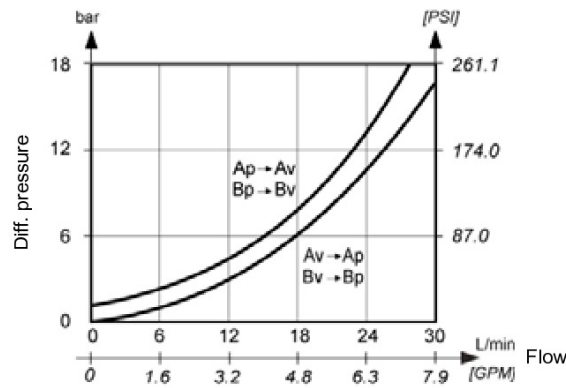

**Dimensions**

EAN, EAP, EAT

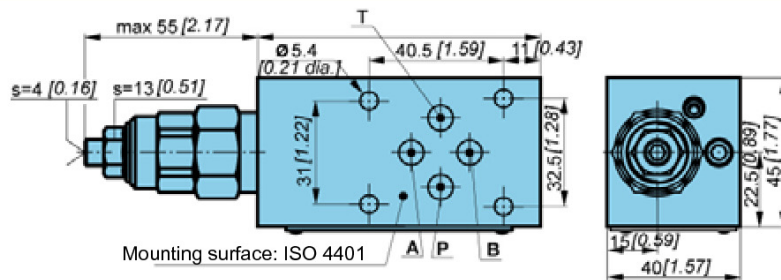

EBN, EBP, EBT

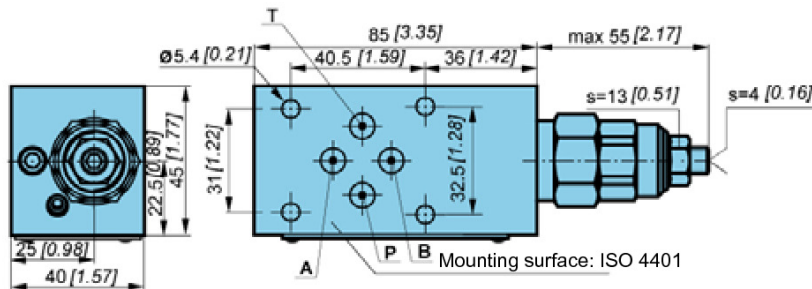

DN, DP, DT

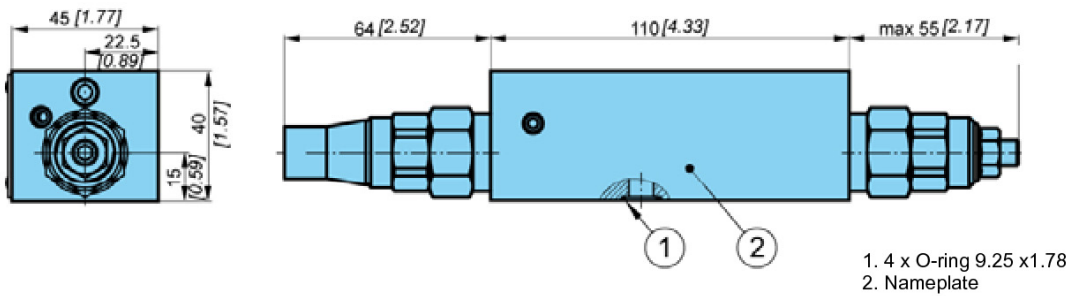

- 1. 4 x O-ring 9.25 x 1.78
- 2. Nameplate

Required quality of the mating surface

