



BRAKE VALVES



VB-200-6. ACCUMULATOR CHARGING VALVES.

HYDRAULIC BRAKE SYSTEM

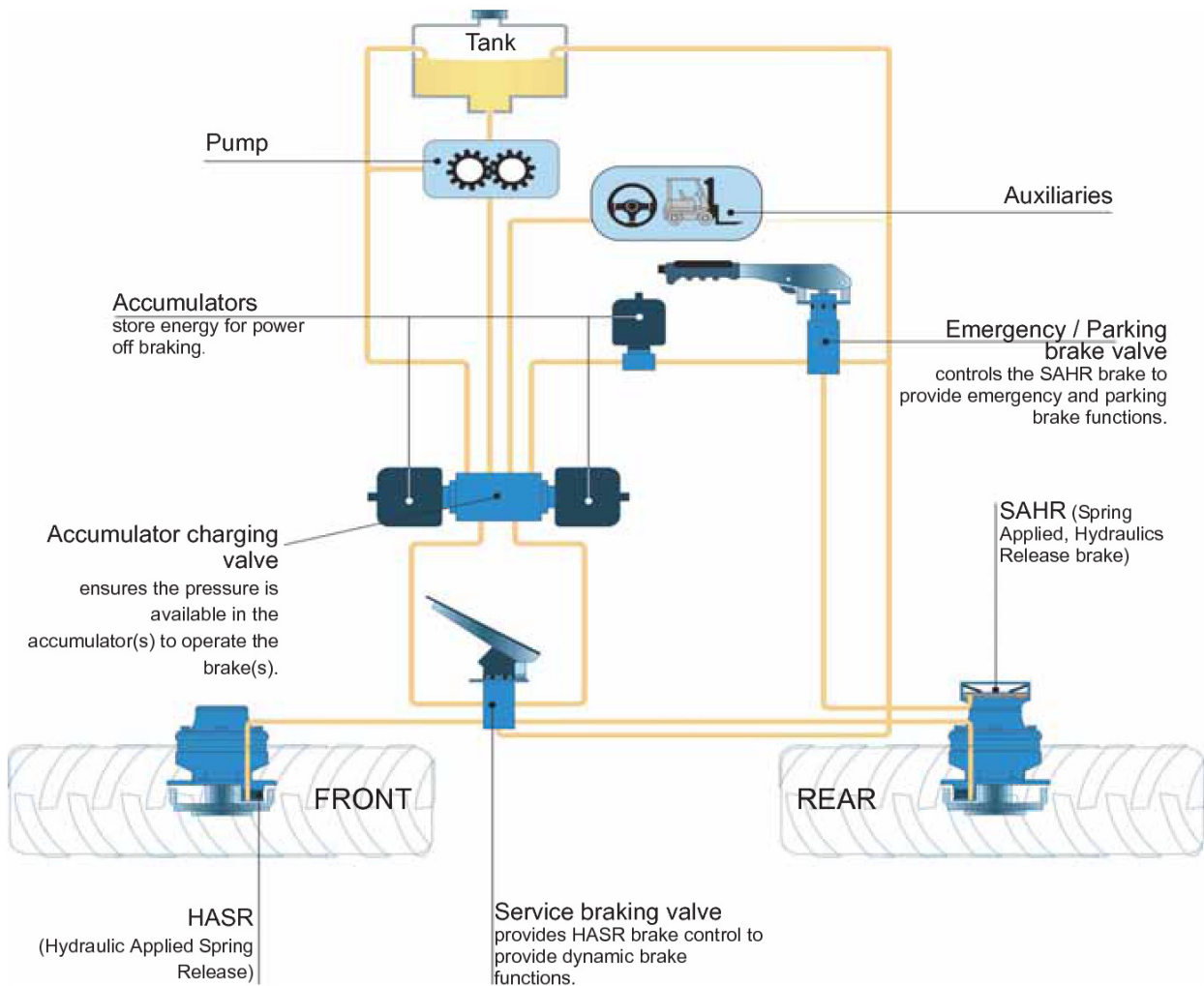

Methodology :

This document is intended for manufacturers of machines that incorporate Poclairn Hydraulics products. It describes the technical characteristics of Poclairn Hydraulics products and specifies installation conditions that will ensure optimum operation.

This document includes important comments concerning safety. They are indicated in the following way:



Safety comment.

This document also includes essential operating instructions for the product and general information. These are indicated in the following way:



Essential instructions.



General information .



Information on the model number. Information on the model code.



Weight of component without oil.



Volume of oil.



Units.



Tightening torque.



Screws.



Information intended for Poclairn-Hydraulics personnel.

The views in this document are created using metric standards.

The dimensional data is given in mm and in inches (inches are between brackets and italic)



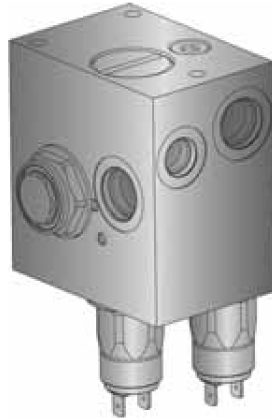

VB-200

- 120 l/min [32 GPM]
- Dual-circuit

Applications

The VB-200 accumulator charging valve charges the accumulators of a braking circuit and maintains their pressure while supplying an auxiliary circuit.

In a braking circuit, valve VB-200 is associated with the VB-020 dual-circuit service brake valve (or the VB-010 single-circuit service brake valve and the VB-002 emergency / parking brake valve).

Operation

During the accumulator charging phase, the built-in divider taps a constant flow from the valve supply flow and diverts it to the accumulators. When the accumulators reach maximum (cut-out) pressure, charging stops, and the entire supply flow is directed to output S (auxiliary circuit or tank return).

Each time the operator actuates the pedal, the pressure in the accumulators drops. When minimum (cut-in) pressure is reached in at least one accumulator, the valve recharges the accumulators to cut-out pressure, and so on.

When a failure occurs in one of the braking circuits, the other circuit is immediately isolated by its safety valve. The circuit that remains operative can then be used as an emergency brake thanks to the energy stored in its accumulator.

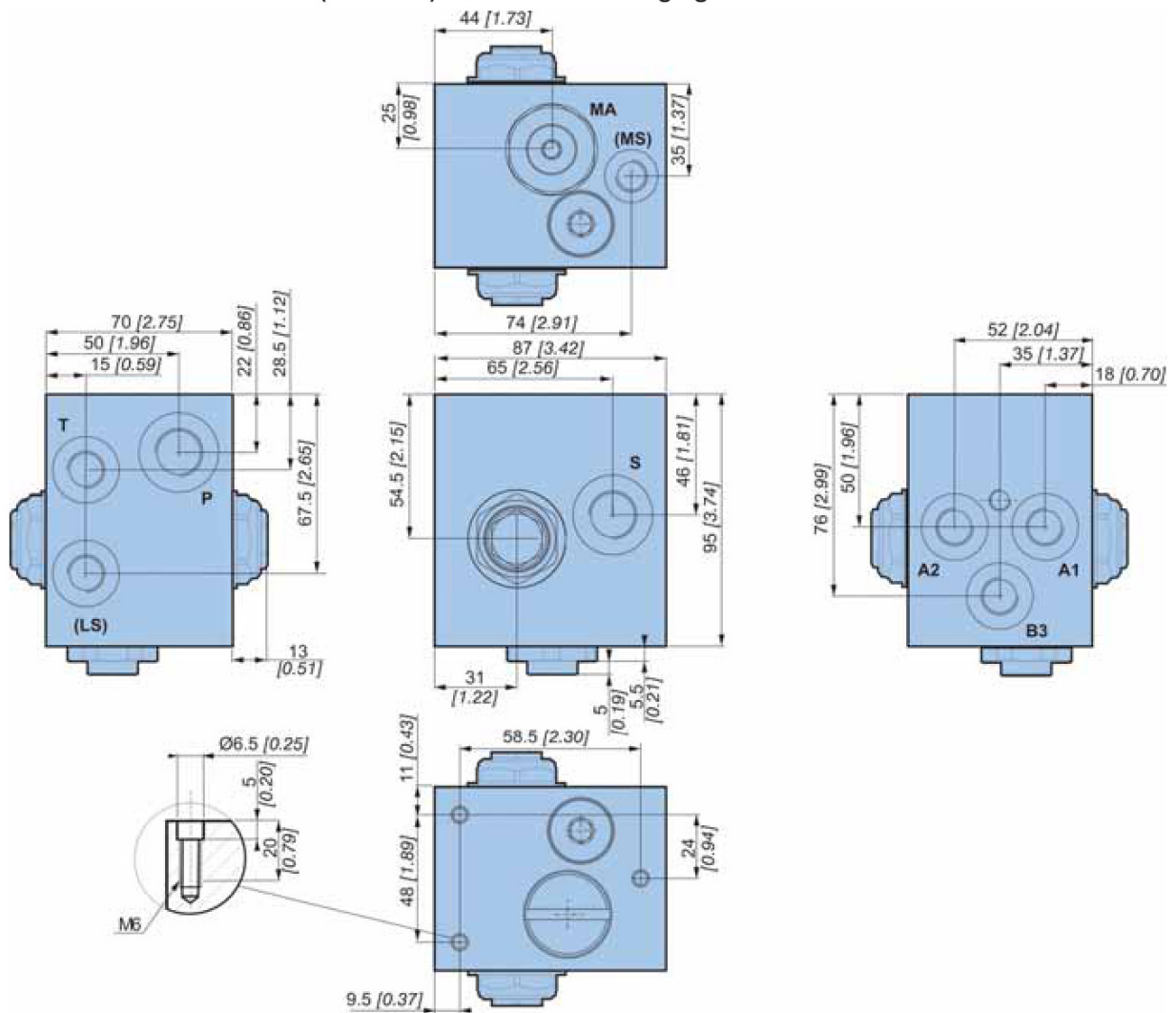
Overall dimensions of VB-200 (120 l/min) accumulators charging valve

Connections

	Max. pressure bar [PSI]	Connection	Function	 kg [lbs]	Loss of head (2) bar [PSI]
P	210 [3 046]	M18 x 1.5	Input	4 [8.8]	4 [58]
S	Cut-out pressure	or 3/4 - 16 UNF	Auxiliary circuit		
T	1 [14,5]		Tank		
A1 - A2	Cut-out pressure (1)	M14 x 1.5	Service braking accumulator		
B3		or 9/16 - 18 UNF	Parking brake connection		
MA*		1/4 BSPP	Accumulator min. pressure switch		
LS*		M14 x 1.5 or 9/16 - 18 UNF	Load sensing		
MS*		M12 x 1.5	MS Pressure switch		

(1) Or max. allowable pressure for the accumulators.

(2) Loss of head (P to S) given at a flow rate (Q = 60 l/min, 16 GPM)

* :Options

Hydraulic diagram

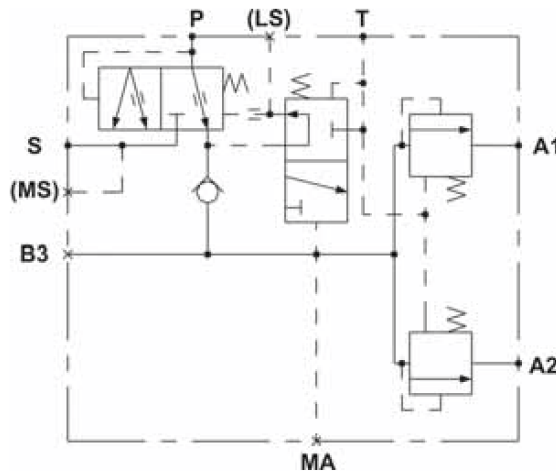

For information concerning special operating conditions (environment, temperatures, etc.), please contact your Poclairn Hydraulics Application Engineer.

Model Code

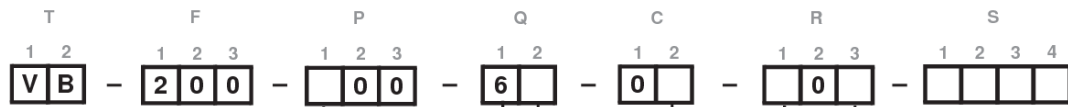

Cut-in/Cut-out range

110 - 130 bar [1595 - 1885 PSI]	3
120 - 140 bar [1740 - 2031 PSI]	4
135 - 160 bar [1958 - 2321 PSI]	5
160 - 190 bar [2321 - 2756 PSI]	6
170 - 200 bar [2466 - 2901 PSI]	7
180 - 210 bar [2611 - 3046 PSI]	8

Flow rate to auxiliaries (P to S)

120 l/min [32 GPM]	6
--------------------	---

Flow rate to accumulator (P to A)

2.75 l/min [0.73 GPM]	1
8 l/min [2.11 GPM]	2
15 l/min [3.96 GPM]	3

Pressure switch **

without	0
on MA (accumulator min. pressure)	1
on MS (auxiliary)	3
on MA and MS	6

Electrical connection

without	0
Deutsch	3
AMP (6.3 X 0.8)	5

Hydraulic connection

ISO 9974-1 (metric fittings)	4
ISO11926-1 (SAE J514 fittings with O-ring)	A



For other operating pressures, please consult your Poclairn Hydraulics Sales Engineer.

** Limitations

Pressure rise	< 1 bar [14.5 PSI] / ms
	min. 100 mA to assure contact
Current	max. 4 A for Resistor load
	max. 2,5 A for Inductive load
Voltage	max. 42 V

Options (See page 81)

Special calibration*	1
Special port*	2
Non-standard component*	3
LS Port	5
MS Port	C
MS + LS Port	D

* Please ask us

OPTIONS



1 Special calibration

Pressure (braking, pressure switch, etc.) or specific flow rate.

2 Special port

Without changing the standard of the other ports.

3 Non-standard component

Installation of a non-standard component (potentiometric sensor, special pressure switch, etc.)

4 Mechanical control adapter



Please contact your Poclain Hydraulics Application Engineer for further information on Options 1 through 4.

5 LS Port

The Load Sensing port (M14 x 1.5 or 9/16" - 18 UNF) is created on request on the standard valve body.

6 Isolating ball valves

In the event of failure of one of the braking circuits, this function acts in a similar way to isolating spool valves by keeping an energy reserve in the accumulator of the non-faulty circuit (limited reserve in the accumulator) and does not maintain pressure in the S line when a circuit has failed (if the steering is fed by the S port of the valve, choose spool valves).

Example of a VB-200 assembly:

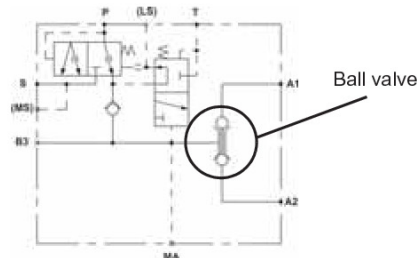

7 Two-slope spring mechanism

For certain applications, the braking sensation, the ergonomics of the pedal board, and the overall behavior of the braked vehicle require a special braking curve. The first part, with its gradual slope, provides gentle, progressive braking to slow the vehicle. The second part, with a steeper slope, provides a braking finish that is progressive but firmer, for emergency braking. According to the shape of the pedal, the user's impression can be similar to a master cylinder. Please ask us about the available pressures.

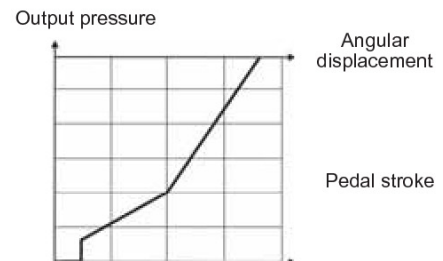

8 Pressure sensor

The sensor (refer to mobile electronics catalog No. A01888C) is installed on the MF port (single-circuit valves) or the MF1 port (dual-circuit valve). It sends a pressure signal to the electronic circuit in the form of an electrical signal that is proportional to the pressure. It can also replace the MF pressure switch in its stop light control function.

9 Pedal back abutment

Prevents the pedal from tilting backward when the floor is inclined.

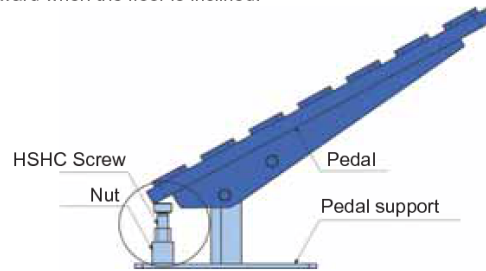

A Improved watertightness

There is a version of the spring mechanism with internal drainage via the brake tank return line for applications in harsh conditions (high humidity, exposed valve, etc.). It is mandatory for open-cabin applications.



Please use extreme care when washing the Brake Valve with a High-Pressure Cleaner. We recommend staying at least 40 cm away from the bonnet of the Brake Valve to avoid water infiltration in the valve.

B Circuit Pressurization

C MS Port

The MS port (12 x 1.5) is added on request to the standard valve body. It is normally used for the installation of the MS pressure switch.

D MS + LS Port

See Options 5 and C.

E N S W Orientation of the mechanical control with respect to the ports

- E : Ports oriented to the right (East)
- N : Ports oriented to the front (North)
- S : Ports oriented to the back (South)
- W : Ports oriented to the left (West).

The installation orientation is defined by the relative position of the valve ports with respect to the conventional direction of operation of a classic vehicle, assuming that the mechanical controls are oriented as follows when idle:
 Pedal: Top of pedal towards the front of the vehicle
 Horizontal lever: Button towards the front of the vehicle
 Vertical lever: Ball towards the front of the vehicle.

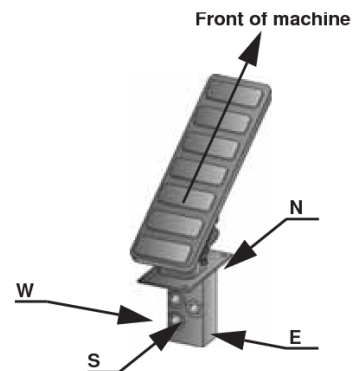

INSTALLATION

Warnings

Before Installation



Take all necessary safety precautions (people and machines) and comply with safety regulations in effect.



Confirm that mobile equipment is immobilized.



Confirm that the hydraulic system's energy generator (motor) is stopped and electrical power is disconnected.



Lay out a safety perimeter.



Do not perform work on a hydraulic system that is hot or under pressure (discharge the accumulators).



Oil that is hot or under pressure can cause serious burns and infection. Consult a physician in case of accident.



Never heat hydraulic fluid which can ignite at high temperature. Some solvents are also inflammable.



Do not smoke while working on the system.



The valves are intended to operate in closed cabins. For applications in harsh conditions (severe weather, marine environment, etc.), please consult your Poclain Hydraulics Application Engineer.



The immediate vicinity of the machine should be declared a security zone. Observe all regulations regarding personnel safety.

General Information

Component Identification



- A:** Model Code:
e.g., VB-220-580-00-C4-504-0000
- B:** Poclair Hydraulics Catalog Number
e.g., R04943301D
- C:** Customer Catalog Number
(on request)
- D:** Serial Number WW/YY
WW : Week of manufacture
YY : Year of manufacture

This number is supplemented by a serial number that is marked by cold heading on the valve body.

Delivery

Valves are delivered in individual bags.



Painted black.



With protected openings (Plastic/metallic plugs or plates with joints for the flanges, sealing them).

Storage

The valves are supplied in bags. If they are to be stored, leave them in the bags. If this is not possible, the valves should be kept in a dry location and protected from dust.

Storage Interval

Depending on the interval and storage conditions, it is necessary to protect the internal components of the hydraulic parts. These operations must be performed before storing components or before stopping use of the machine.

Climate	Storage interval (months)			
	3	6	12	18
Temperate	A	B	C	C
Tropical	B	C	D	D
	C	D	D	D

Legend

- A** - No specific precaution; only check the proper mounting of the plugs and covers.
- B** - Fill up with hydraulic fluid
- C** - Rinse with storage fluid
- D** - Fill up with storage fluid.



Storage areas must not be open (without a roof). The valves must not be laid on the ground.

Paint

- Use paints compatible with the existing base coat.
- The Poclair Hydraulics components (like any mechanical component) can rust. They must be effectively and regularly protected according to the environment where they are used. During installation, any trace of rust must be eliminated before painting the machine.

Primer Specifications

Number	Color	Brilliance	Saline mist	Adhesion	Hardness
RAL 9005	Black	ISO 2813 40%	ISO 9227 > 400 h	ISO 2409 0	ASTM D3363 HB



These specifications vary with the supplier, but meet these minima. For more information, consult your Poclair Hydraulic's application engineer.

Circuits

Checking Connections



Piping and Connections

The different components of the hydraulic circuit (tank, pumps, distributors, filters, sinks, etc.) are connected together by rigid piping or flexible hoses.

Suggested connection:



Screwed Connections

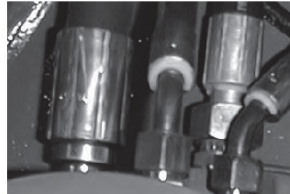

Comply with the connection directions given by the manufacturers for each part: function and marking of the ports, types of connections, diameters, types of lines (flexible or rigid), etc.

Rigid Tubes

For high-pressure pipes, only use unwelded cold-drawn steel pipes.



Take the following precautions for making up the tubes:

- After cutting to length, cold bending and crimping, the tubes must be carefully deburred, rinsed with oil and blown before connection.
- After welding or bending, the tubes must be etched (solution based on sulfuric acid) then rinsed with oil and neutralized (solution based on sodium hydroxide).
- The connections, threaded plugs, etc. must be deburred and cleaned before assembly.
- If assembly is not done immediately, seal the ports with plugs.



Flexible Tubes

Only use flexible tubes with crimped ends.

Avoid contacts likely to break down the flexible tubes.

As needed protect them with armor.



Avoid kinks.



Observe the minimum radius of curvature.

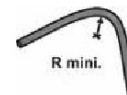

The tube's interior diameter must be greater than or equal to the diameter of the connection openings of the components.

Connection

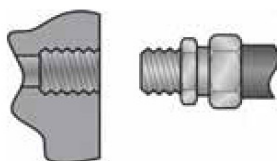

Check the compatibility of the types of connections between the tubes and the motor's ports. If they are not compatible, use adapter fittings.

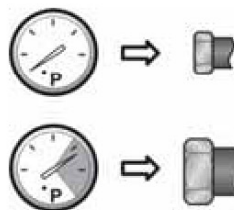

Ensure that the class of fitting is suitable for the operating pressure.

Bleed

To bleed your braking system, refer to the brake manufacturer's recommendations.



Rinse the brakes pilot circuit before connection.

Oils

Fluid Selection



General Recommendations

Poclain Hydraulics recommends the use of hydraulic fluids defined by the ISO 12922 and ISO 6743-4 standards. For temperate climates, the following types are recommended.

- HM 46 or HM 48 for fixed installations.
- HV 46 or HV 68 for mobile installations.
- HEES 46 for mobile installations.

These specifications correspond to category 91H of the CETOP standard, parts 1, 2 and 3 of the DIN 51524 standard, and grades VG32, VG 46 and VG68 of the ISO 6743-4 standards.



It is also possible to use ATF, HD, HFB, HFC or HFD type hydraulic fluid upon Poclain Hydraulics specific approval of the components' operating conditions.



Standardized designations for the fluids

- **HM** : Mineral fluids having specific antioxidant, anticorrosion and antiwear properties (HLP equivalent to DIN 51524 parts 1 and 2).
- **HV** : HM mineral fluids providing improved temperature and viscosity properties (DIN 51524 part 3).
- **HEES** : Biodegradable fluids based on organic esters.



Class 32 (ISO VG 32) : Viscosity of 32 cSt at 40°C.

Class 46 (ISO VG 46) : Viscosity of 46 cSt at 40°C.

Class 68 (ISO VG 68) : Viscosity of 68 cSt at 40°C.



Viscosity must always be between 9 and 500 cSt. If not, check the appropriateness of the cooling circuit, the design, or the grade of oil.

For all applications outside these limits, please consult your Poclain Hydraulics Application Engineer.

Extract of the NF ISO 11 158 Standard

Tests	Test Methods or Standards	HM Category					Units
		Viscosity Grade					
		22	32	46	68	100	
Kinematic viscosity at 40°	ISO 3104	19.8 24.2	28.8 to 35.2	41.4 50.6	61.2 to 74.8	90 110	mm ² / s
Minimum viscosity index (a)	ISO 2909	-	-	-	-	-	1
Acidity index, maximum (b)	ISO 6618	(c)	(c)	(c)	(c)	(c)	mg KOH / g
Water content, maximum	ASTM D 1744 DIN 51777-1 DIN 51777-2 (d)	500	500	500	500	500	mg / kg
Flash point Cleveland in open-cup, min.	ISO 2592	140	160	180	180	180	°C
Foaming at 24°C, max. 93°C, max.	ISO 6247	150/0 75/0	150/0 75/0	150/0 75/0	150/0 75/0	150/0 75/0	ml
Deaeration at 50°C, maximum	ISO 9120	5	5	10	13	21	min
Copper blade corrosion at 100°C, 3 h maximum	ISO 2160	2	2	2	2	2	Grading
Anti-rust power, method A	ISO 7120	Pass	Pass	Pass	Pass	Pass	
Anti-wear property, FZG A/8, 3/90, minimum	DIN 51354-2	(e)	10	10	10	10	Deterioration Level
Flow point, maximum	ISO 3016	-18	-15	-12	-12	-12	°C
Aptitude to separate from water: Time needed to obtain 3 ml of emulsion at 54°C, max.	ISO 6614	30	30	30	30		min

Tests	Test Methods or Standards	HV Category					Units
		Viscosity Grade					
		22	32	46	68	100	
Kinematic viscosity at 40°	ISO 3104	19.8 24.2	28.8 to 35.2	41.4 50.6	61.2 to 74.8	90 110	mm ² / s
Minimum viscosity index (a)	ISO 2909	130	130	130	130	130	1
Acidity index, maximum (b)	ISO 6618	(c)	(c)	(c)	(c)	(c)	mg KOH / g
Water content, maximum	ASTM D 1744 DIN 51777-1 DIN 51777-2 (d)	500	500	500	500	500	mg / kg
Flash point Cleveland in open-cup, min.	ISO 2592	140	160	180	180	180	°C
Foaming at 24°C, max. 93°C, max.	ISO 6247	150/0 75/0	150/0 75/0	150/0 75/0	150/0 75/0	150/0 75/0	ml
Deaeration at 50°C, maximum	ISO 9120	7	7	12	12	20	
Copper blade corrosion at 100°C, 3 h maximum	ISO 2160	2	2	2	2	2	Grading
Anti-rust power, method A	ISO 7120	Pass	Pass	Pass	Pass	Pass	
Anti-wear property, FZG A/8, 3/90, minimum	DIN 51354-2	(e)	10	10	10	10	Deterioration Level
Flow point, maximum	ISO 3016	-42	-36	-36	-30	-21	°C
Aptitude to separate from water: Time needed to obtain 3 ml of emulsion at 54°C, max.	ISO 6614	(c)	(c)	(c)	(c)	(c)	

- (a) These limits should only be taken into consideration for fluids made from hydrocracked or hydro-isomerized mineral oils.
 (b) Both base fluids and additives contribute to the initial acidity index.
 (c) The behavior criteria or the values of properties must be the subject of negotiation between the supplier and the end user.
 (d) The DIN 51777-2 standard applies in cases where interference caused by certain chemical compounds must be avoided. Free bases, oxidizing or reducing agents, mercaptans, some nitrogenous products or other products that react with iodine interfere.
 (e) Not applicable to ISO 22 viscosity grade.

Extract of the ISO 15 380 Standard

Tests	Test Methods or Standards	HM Category				Units
		Viscosity Grade				
		22	32	46	68	
Kinematic viscosity at 40°	ISO 3104	19.8 24.2	28.8 to 35.2	41.4 50.6	61.2 to 74.8	mm ² / s
Minimum viscosity index (a)	ISO 2909	-	-	-	-	
Acidity index, maximum (b)	ISO 6618	(c)	(c)	(c)	(c)	mg KOH / g
Water content, maximum	ASTM D 1744 DIN 51777-1 DIN 51777-2 (d)	1000	1000	1000	1000	mg / kg
Flash point Cleveland in open-cup, min.	ISO 2592	165	175	185	195	°C
Foaming at 24°C, max. 93°C, max.	ISO 6247	150/0 75/0	150/0 75/0	150/0 75/0	150/0 75/0	ml
Deaeration at 50°C, maximum	ISO 9120	7	7	10	10	min
Copper blade corrosion at 100°C, 3 h maximum	ISO 2160	2	2	2	2	Grading
Anti-rust power, method A	ISO 7120	Pass	Pass	Pass	Pass	
Anti-wear property, FZG A/8, 3/90, minimum	DIN 51354-2	(e)	10	10	10	Deterioration Level
Flow point, maximum	ISO 3016	-21	-18	-15	-12	°C
Aptitude to separate from water: Time needed to obtain 3 ml of emulsion at 54°C, max.	ISO 6614	(c)	(c)	(c)	(c)	min

Tests	Test Methods or Standards	HV Category				Units
		Viscosity Grade				
		22	32	46	68	
Kinematic viscosity at 40°	ISO 3104	19.8 24.2	28.8 to 35.2	41.4 50.6	61.2 to 74.8	mm ² / s
Minimum viscosity index (a)	ISO 2909	-	-	-	-	1
Acidity index, maximum (b)	ISO 6618	(c)	(c)	(c)	(c)	mg KOH / g
Water content, maximum	ASTM D 1744 DIN 51777-1 DIN 51777-2 (d)	1000	1000	1000	1000	mg / kg
Flash point Cleveland in open-cup, min.	ISO 2592	165	175	185	195	°C
Foaming at 24°C, max. 93°C, max.	ISO 6247	150/0 75/0	150/0 75/0	150/0 75/0	150/0 75/0	ml
Deaeration at 50°C, maximum	ISO 9120	7	7	10	10	min
Copper blade corrosion at 100°C, 3 h maximum	ISO 2160	2	2	2	2	Grading
Anti-rust power, method A	ISO 7120	Pass	Pass	Pass	Pass	
Anti-wear property, FZG A/8, 3/90, minimum	DIN 51354-2	(e)	10	10	10	Deterioration Level
Flow point, maximum	ISO 3016	(c)	(c)	(c)	(c)	°C
Aptitude to separate from water: Time needed to obtain 3 ml of emulsion at 54°C, max.	ISO 6614	(c)	(c)	(c)	(c)	min

(a) These limits should only be taken into consideration for fluids made from hydrocracked or hydro-isomerized mineral oils.

(b) Both base fluids and additives contribute to the initial acidity index.

(c) The behavior criteria or the values of properties must be the subject of negotiation between the supplier and the end user.

(d) The DIN 51777-2 standard applies in cases where interference caused by certain chemical compounds must be avoided. Free bases, oxidizing or reducing agents, mercaptans, some nitrogenous products or other products that react with iodine interfere.

(e) Not applicable to ISO 22 viscosity grade.

Temperature and Viscosity

The best performance is obtained by having the system operate in the regimes shaded gray.

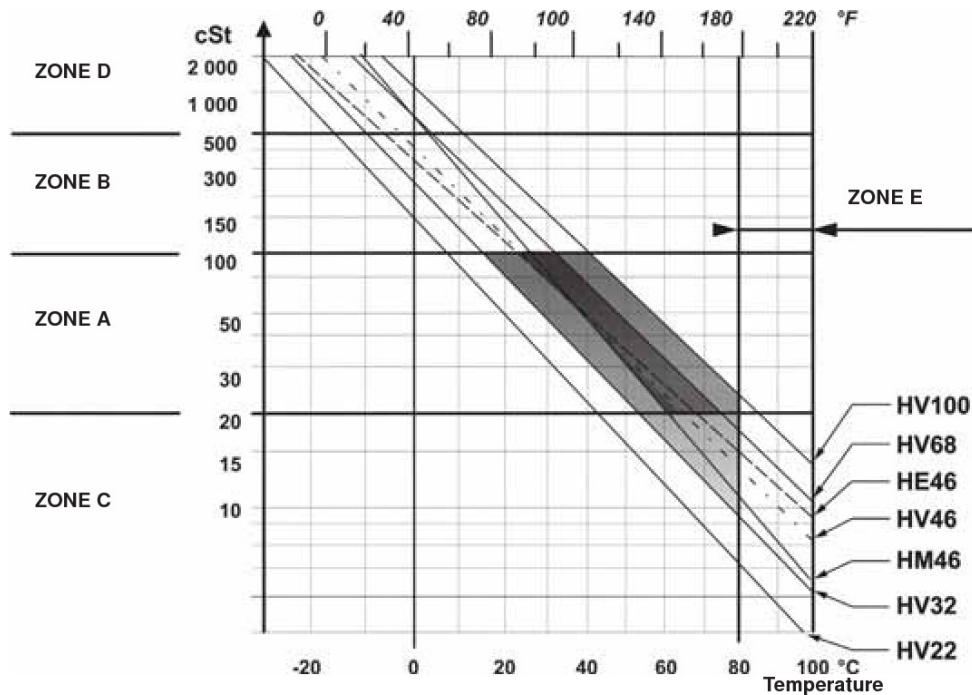

Zone A	<p>Zone of maximum efficiency.</p> <p>In this zone, temperature variations have a weak effect on the response time, efficiency and life expectancy of the components.</p> <p>Poclair Hydraulics components can operate at all speeds, pressures and powers specified in their technical documentation.</p>
Zone B	<p>High speeds can lead to vibrations and drops in mechanical efficiency. The booster pump can cavitate if the intake conditions are too tight but without risk for the system as long as the pump remains boosted.</p> <p>The Poclair Hydraulics components can operate at the pressures specified in their documentation but it is not advisable to use the pumps at full displacement.</p> <p>In a translation circuit, a rapid rise in the pump speed from zone B is allowed, but ordering the translation when the temperature has reached zone A is recommended.</p>
Zone C	<p>The efficiency is less and the use of effective antiwear additives is required.</p> <p>The Poclair hydraulics components can temporarily operate at a power under 20 to 50% of that stated in the technical documentation, or during 20% of the operating time at the stated power.</p>
Zone D	<p>The stated restrictions for zone B likewise apply to zone D.</p> <p>Further, the pumps must startup at low speed and no displacement. They must not be used in their normal operating conditions as long as the booster pressure has not stabilized and the hydraulic fluid temperature in the reservoir has not come up to zone B.</p>
Zone E	<p>The efficiency is reduced and the risk of wear on the pump and hydraulic fluid is increased.</p> <p>The system can operate in zone E at low-pressure and during short periods.</p> <p>The temperature of the hydraulic fluid in the power circuit must not be more than 10°C above the temperature of the hydraulic fluid in the reservoir, and must not be more than 20°C warmer than the hydraulic fluid in the components' cases.</p>

Water Content

The ISO 12922 standard calls for a water content $\leq 0.05\%$.

Poclain Hydraulics components tolerate up to 0.1%.

Checking Water Content



Visual Inspection

- The oil appears cloudy once it has a water concentration greater than or equal to 1%.

We suggest two possible verification methods:

1- Quick Elementary Check



- The "crackle test."

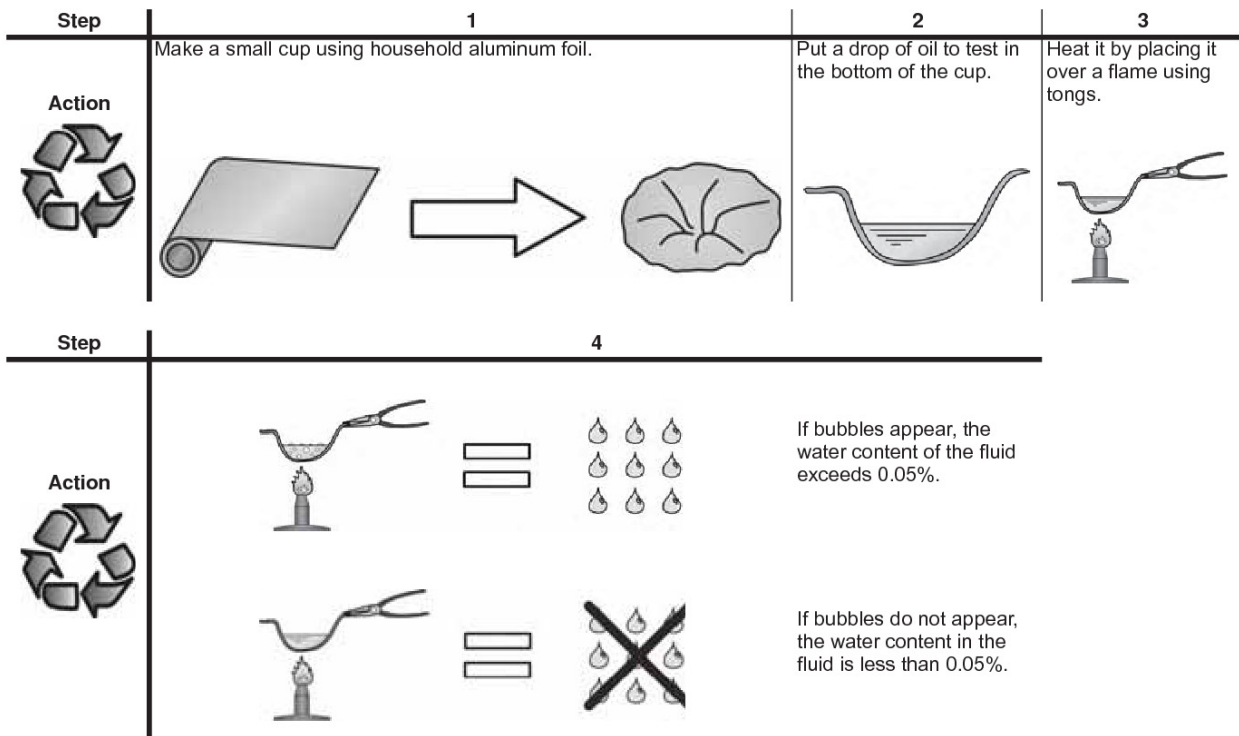

2- Laboratory analysis

To determine the exact water content of the fluid, we recommend a laboratory analysis.



Poclain Hydraulics performs laboratory analyses of water content in fluids. Contact us for further information.

Decontamination and Filtration



The life of hydraulic components is lengthened when the contamination level is low.

The hydraulic fluid must be maintained at ISO standard 4406 -1999 decontamination level 18/16/13 (class 7 from NAS 1638) using a filter.

Braking circuit example:

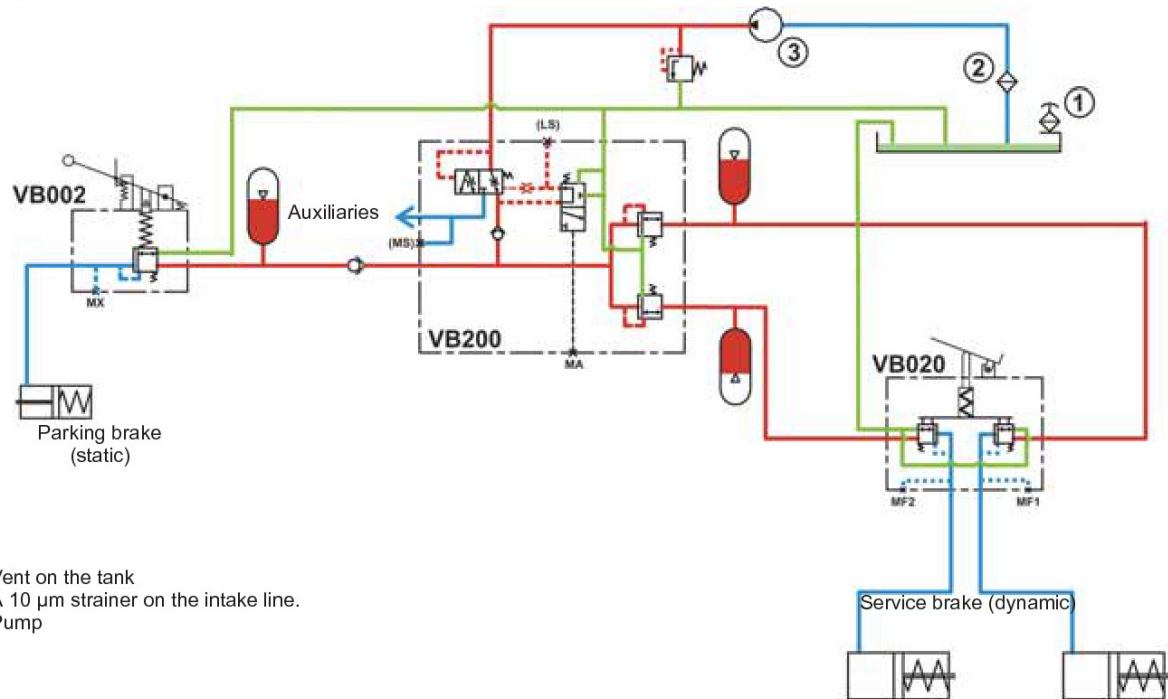

Consult manufacturer's instructions for components (filters, pumps, valves, etc.).



The recommended intake filter size is four-time state of the booster pump.



New fluid is generally of lower quality than our requirements. Poclairn Hydraulics asks its customers to fill or adjust the levels in the reservoirs in a clean environment using a pump and filter.

Return line

It is **ESSENTIAL** to connect the valve return line directly to the tank.



Any counterpressure on the return line can cause premature brake wear without any use of the pedal.

Accumulators

- Select accumulators whose maximum allowable pressure is compatible with the valve pressures.
- Accumulator charging valve: any pressure on S (higher than the cut-out pressure) ends up in the accumulator(s) of the braking circuit.

Mounting

The mounting is defined for each valve type, and depends on the type of mechanical control selected.



When the valve is installed, the pedal must not be obstructed during its stroke.





The valve bodies must never touch other components (min. clearance 5 mm [0.20 in]).

Recommended screw torques:

Screws and Bolts	Nominal Dimension	Quality Class		
		8,8 N.m [lb.ft]	10,9 N.m [lb.ft]	12,9 N.m [lb.ft]
Normal Spaced Threads C HC	M6	10 [7]	14 [10]	17 [13]
	M8	24 [18]	35 [26]	41 [30]
	M10	49 [36]	69 [51]	83 [61]
	M12	86 [63]	120 [89]	145 [107]
	M14	135 [100]	190 [140]	230 [170]
	M16	210 [155]	295 [218]	355 [262]
	M18	290 [214]	405 [299]	485 [358]
	M20	410 [303]	580 [428]	690 [509]
	M22	550 [406]	780 [576]	930 [686]
	M24	710 [524]	1000 [738]	1200 [886]

Connection

Connectors	Nominal Dimension	Tightening Torque
		
		N.m [lb.ft]
	M10 x 1	45 [33]
	M12 x 1	45 [33]
	M12 x 1.5	45 [33]
	M14 x 1.5	45 [33]
	M16 x 1.5	60 [44]
	M18 x 1.5	70 [52]
	M22 x 1.5	100 [74]
	M27 x 2	200 [148]
	Ø 13	30 [22]
	Ø 17	55 [41]
	Ø 21 (BP)	100 [74]
	Ø 21 (HP)	160 [118]
	Ø 27	200 [148]
	1"1/16 - 12 UNF	170 [125]
	3/4" - 16 UNF	70 [52]
	9/16" - 18 UNF	35 [26]
	7/8" - 14 UNF	100 [74]

(BP) : Low Pressure
(HP) : High Pressure