

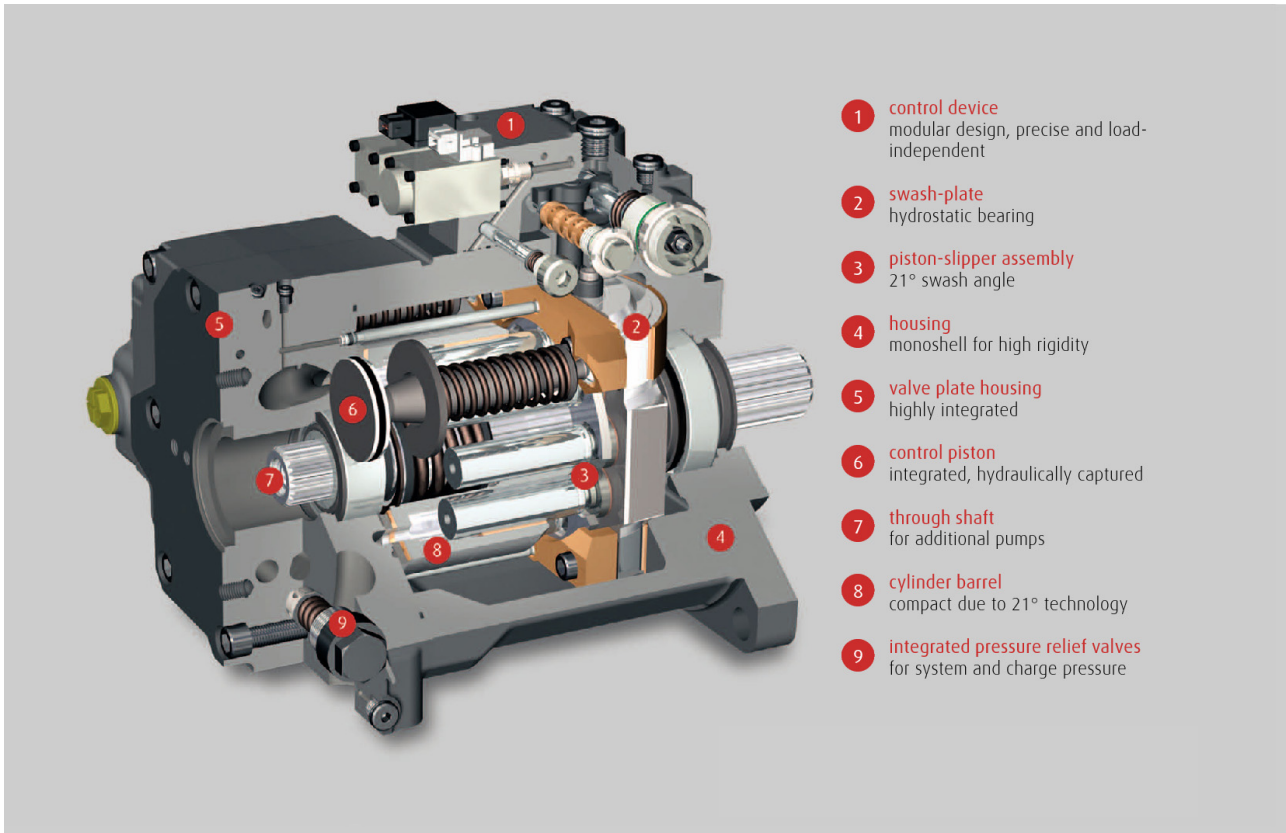

PUMP



HPV-02. VARIABLE PUMPS FOR CLOSED CIRCUIT OPERATION



Design characteristics

- >> axial piston pump in swashplate design for high pressure closed loop systems
- >> clockwise or counter clockwise rotation
- >> exact and rugged servo control devices (mechanical, hydraulic, electro-hydraulic)
- >> integrated high pressure relief valves with make-up function
- >> integrated low pressure relief valves for charge, control and cooler circuits
- >> replaceable cartridge filter
- >> SAE high pressure ports
- >> SAE mounting flange with ANSI or SAE spine shaft
- >> through shaft SAE A, B, B-B, C, D and E
- >> charge pressure pumps for internal and external suction, integrated cold start relief valve optional
- >> hydrostatic bearings of the rotating group compensate for axial forces
- >> optional tandem and multiple pumps

Product advantages

- >> compact design
- >> high power density
- >> dynamic response
- >> high reliability
- >> long service life
- >> noise-optimized
- >> precise and load-independent servo control

LinDrive = Precision x Dynamics x Reliability = Benefitⁿ



LINDE HYDRAULICS PRODUCT RANGE

Find the right products for your application.

Product range

Product		Application	Linde product name
Pump	Self-regulating pump	open loop operation	HPR-02
	Variable pump	closed loop operation	HPV-02
Motor	Variable motor	closed and open loop operation	HMV-02
	Regulating motor	closed and open loop operation	HMR-02
	Fixed motor	closed and open loop operation	HMF-02
		open loop operation	HMF-02 P
Valve Technology	LSC manifold plate	closed and open loop operation	HMA-02
		open loop operation	VT modular
	Monoblock	open loop operation	Monoblock
Electronics	Electronic control unit	closed and open loop operation	LINC
	Peripheral equipment	closed and open loop operation	
	Software	diagnosis and configuration	LinDiag®

CONTENT HPV-02

The closed loop	4	Dimensions	
General technical data	5	>> M-controls	26
Operational parameters		>> H-controls	27
>> Life time recommendations	6	>> CA-controls	28
>> Filtration	6	>> E-controls	29
>> Pressure fluids and mounting orientation	7	>> Modular system	30
Torque transmission	8	>> HPV-02 tandem pumps	33
>> Mounting flange	9	>> HPV-HPR-02 multiple pumps	34
>> Drive shaft	10	Modular system features	35
>> PTO flange	11	Your notes	35
>> Output shaft	11	Contact	36
Gear pumps	12		
Controls	15		
>> Control accuracy	16		
>> M. Mechanical-hydraulic	17		
>> H. Hydraulic	19		
>> CA. Hydraulic-mechanical	21		
>> E. Electro-hydraulic	22		

The data on which this brochure is based correspond to the current state of development. We reserve the right to make changes in case of technical progress. The dimensions and technical data of the individual installation drawings are prevailing. The features listed in this data sheet are not available in all combinations and nominal sizes. Our sales engineers will be happy to provide advice regarding the configuration of your hydraulic system and on product selection.



THE CLOSED LOOP.

Representation of the hydraulic components of a closed loop hydrostatic drive: Variable electro-hydraulic controlled pump HPV-02 E1 (top view) and fixed displacement motor HMF-02 plus filter, cooler and oil tank. The function diagram and the circuit diagram show two types of cooling.

Function diagram

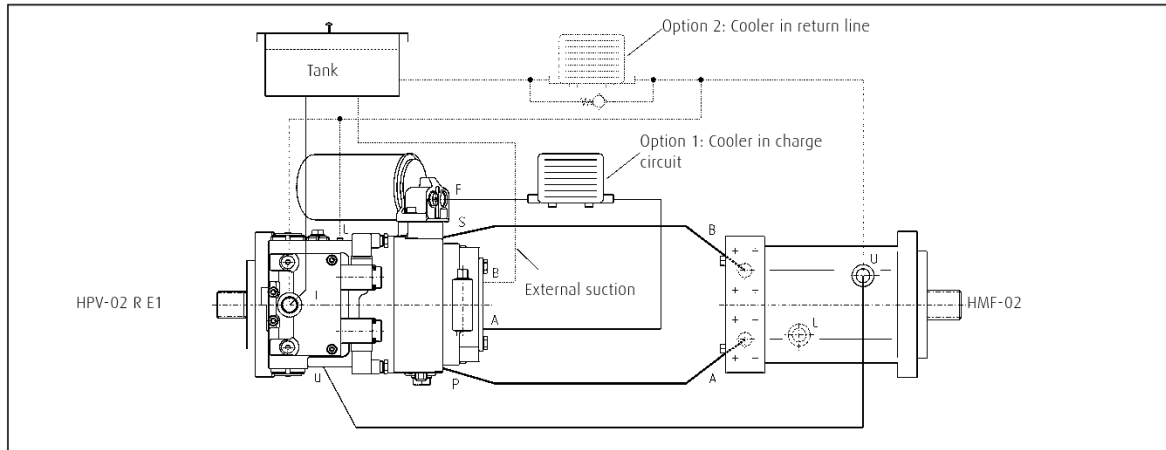

Circuit diagram

The boost pump is shown with internal and external suction.

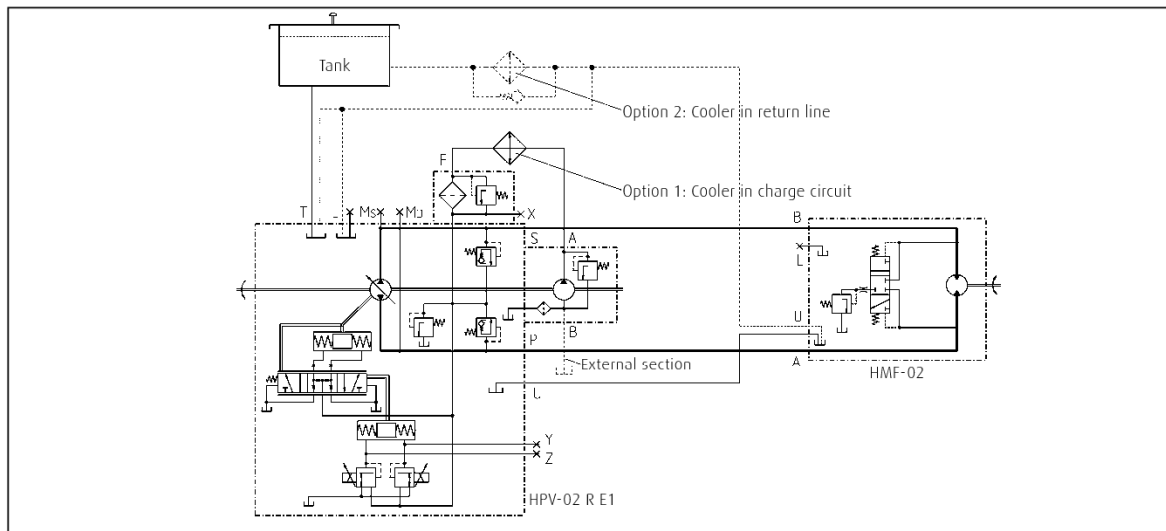

Standard Linde name plate

Each Linde Hydraulics unit features a name plate showing the type and the serial number. For a single order via 'open variant' a customer-specific number or free text with up to 15 characters can be stamped on the name plate.

Type	HPV105-02	Series 02 variable pump, rated size 105
	R	Right hand rotation
	2553	the last 4 figures of the Bill of Material
Serial-No.	H2X	
	264	Type number of HPV 105-02
	T	Letter indicating year of production
	12345	Serial number
Part No.	12345678	Free text field for up to 15 characters



GENERAL TECHNICAL DATA.

The table shows the complete capacity range of the pumps, while the diagram below shows the recommended practical range for the different nominal sizes of the HPV-02 pump with control limit between 200 bar Δp_{min} and 280 bar Δp_{max} . It enables initial selection of the required nominal pump size.

Overview of technical data

Rated size			55	75	105	135	165	210	280
			Maximum displacement	cc/rev	54.7	75.9	105	135.7	165.6
Speed	Maximum continuous speed	rpm	3300	3100	2900	2700	2500	2300	2000
	Maximum speed (intermittent)	rpm	3700	3500	3200	2900	2700	2500	2200
	Minimum continuous speed	rpm	500						
Pressure	Maximum operating pressure	bar	420						
	Max. pressure (intermittent)	bar	500						
	Continuous pressure (Δp)	bar	250						
	Permissible housing pressure absolute	bar	2.5						
Torque HPV without charge pump	Continuous input torque at continuous pressure	Nm	218	302	418	540	659	836	1122
	Maximum input torque at max. op. pressure, 19 bar charge pressure	Nm	353	489	677	875	1067	1354	1817
Power	Continuous power at max. cont. speed, cont. pressure	kW	75	98	127	153	173	201	235
	Maximum power at max. cont. speed, max. op. pressure, 19 bar charge pressure	kW	122	159	206	247	279	326	381
Permissible shaft loads	Axial	N	2000						
	Radial	N	on request						
Permissible housing temperature	Perm. housing temperature with minimum perm. viscosity > 10 cst	°C	90						
Weights inclusive IGP (size 55-135) or EGP (size 165-280)	HPV-02 with H1-control without oil (approx.)	kg	46	49	66	72	113	132	164
	Filling volume HPV-02 housing with filter	dm ³	2.1	2.8	3.4	3.8	4.2	4.8	5.5
	Maximum moment of inertia	kgm ² 10 ⁻²	0.54	0.84	1.49	2.2	3.11	4.77	9.38

Recommended operating range of HPV-02

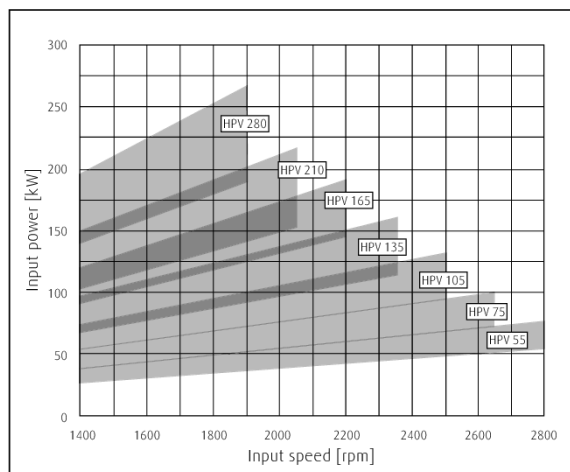

OPERATIONAL PARAMETERS. LIFE TIME RECOMMENDATIONS

Linde high pressure units are designed for excellent reliability and long service life. The actual service life of a hydraulic unit is determined by numerous factors. It can be extended significantly through proper maintenance of the hydraulic system and by using high-quality hydraulic fluid.

Beneficial conditions for long service life

- >> Speed lower continuous maximum speed
- >> Operating pressure less than 300 bar Δp on average
- >> Max. pressure only at reduced displacement
- >> Viscosity 15 ... 30 cSt
- >> Power continuous power or lower
- >> Purity of fluid 18/16/13 in acc. with ISO 4406 or better

Adverse factors affecting service life

- >> Speed between continuous maximum speed and intermittent maximum speed
- >> Operating pressure more than 300 bar Δp on average
- >> Viscosity less than 10 cSt
- >> Power continuous operation close to max. power
- >> Purity of fluid lower than 18/16/13 in acc. with ISO 4406

Operational parameters. Filtration

In order to guarantee long-term proper function and high efficiency of the hydraulic pumps the purity of the pressure fluid must comply with the following criteria according to Linde Works Standard WN 51 210. High purity oil can extend the service time of the hydraulic system significantly.

- >> For reliable proper function and long service life 18/16/13 in accordance with ISO 4406 or better
- >> Minimum requirements 20/18/15 in accordance with ISO 4406
- >> Commissioning The minimum purity requirement for the hydraulic oil is based on the most sensitive system component. For commissioning we recommend a filtration in order to achieve the required purity.
- >> Filling and operation of hydraulic systems The required purity of the hydraulic oil must be ensured during filling or topping up. When drums, canisters or large-capacity tanks are used the oil generally has to be filtered. We recommend the implementation of suitable measures (e.g. filters) to ensure that the required minimum purity of the oil is also achieved during operation.
- >> International standard

code number according to ISO 4406	purity class according to SAE AS 4059
18/16/13	corresponds to 8A/7B/7C
20/18/15	9A/8B/8C

Filters

Units of the HPV-02 series can be equipped with a pure charge pressure manifold or with a combined charge pressure and filter flange manifold. The following filter sizes are available, depending on the rated size of the unit. Further details about the mounting of the charge pressure manifold see section "Dimensions. Modular System".

Filter	55	75	105	135	165	210	280
Nr. 2	x						
Nr. 3	x	x	x	x	x	x	x

OPERATIONAL PARAMETERS. PRESSURE FLUIDS AND MOUNTING ORIENTATION

In order to ensure the functional performance and high efficiency of the hydraulic pumps the viscosity and purity of the operating fluid should meet the different operational requirements. Linde recommends using only hydraulic fluids which are confirmed by the manufacturer as suitable for use in high pressure hydraulic installations or approved by the original equipment manufacturer.

Permitted pressure fluids

- >> mineral oil HLP to DIN 51 524-2
- >> biodegradable fluids in accordance with ISO 15 380 on request
- >> other pressure fluids on request

Linde offers an oil testing service in accordance with VDMA 24 570 and the test apparatus required for in-house testing. Prices available on request.

Recommend viscosity ranges

Pressure fluid temperature range	[°C]	-20 to +90
Working viscosity range	[mm ² /s] = [cSt]	10 to 80
Optimum working viscosity	[mm ² /s] = [cSt]	15 to 30
Max. viscosity (short time start up)	[mm ² /s] = [cSt]	1000

In order to be able to select the right hydraulic fluid it is necessary to know the working temperature in the hydraulic circuit. The hydraulic fluid should be selected such that its optimum viscosity is within the working temperature range (see tables).

The temperature should not exceed 90 °C in any part of the system. Due to pressure and speed influences the leakage fluid temperature is always higher than the circuit temperature. Please contact Linde if the stated conditions cannot be met in special circumstances.

Viscosity recommendations

Working temperature [°C]	Viscosity class [mm ² /s] = [cSt] at 40 °C
approx. 30 to 40	22
approx. 40 to 60	32
approx. 60 to 80	46 or 68

Mounting orientation

The preferred mounting orientation is generally horizontal. Special pump configurations for vertical mounting with the drive shaft pointing either upward or downward are available for selected rated sizes and have to be requested separately. For further information concerning the installation of the unit please refer to the operating instructions manual.

TORQUE TRANSMISSION.

Depending on the selected components, different torques may be transferred. Please ensure that the load transfer components such as mounting flange, PTO-through shaft and additional pumps are designed adequately. Our sales engineers will be pleased to provide design advice.

Torque transmission of HPV-02

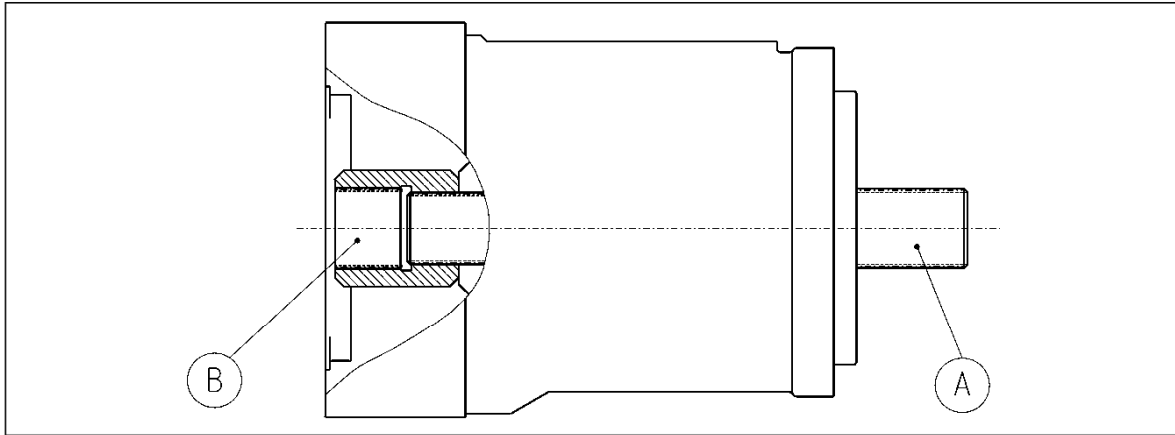

This shows the input side (A) and PTO-/output side (B) of a HPV-02 pump. The information on the following pages refers to
 >> mounting flange and drive shaft (A)
 >> PTO flange and through shaft (B).

A) Flange profile

Bolt hole dimensions								
		55	75	105	135	165	210	280
M1 inside diameter	mm	17.5	17.5	17.5	21.5	21.5	22	22
M2 outside diameter	mm	34	40	34	40	40	38	39
M3 length	mm	20	20	25	20	25	30	30

Bolt hole diameter

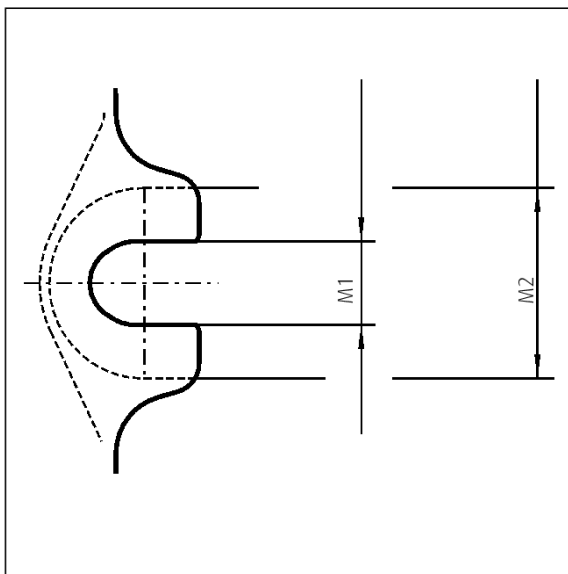

Bolt hole length

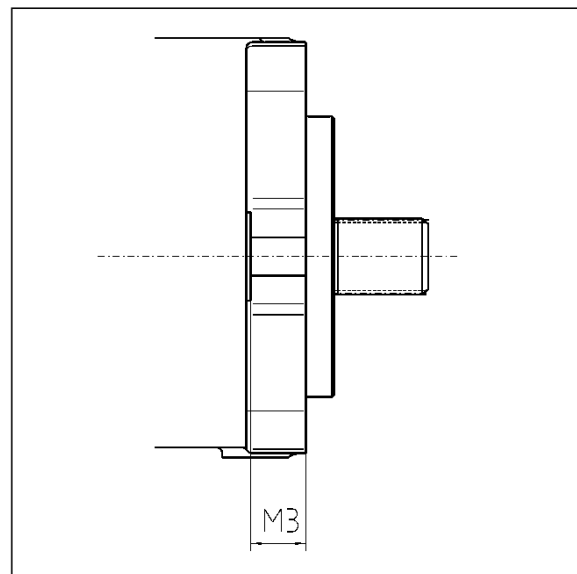

TORQUE TRANSMISSION. MOUNTING FLANGE

Mounting flange in accordance with SAE J744	For rated size	Mounting				Dimensions			
		Washer	Screw	Torque (8.8) [Nm]	Torque (10.9)* [Nm]	K [mm]	H [mm]	V [mm]	G [mm]
SAE C, 2 hole	55, 75, 105	17x33x10	M16	195	275	181.0	-	-	-
SAE C, 2 hole with 4 additional threads M12	75 & 105	17x33x10	M16	195	275	181.0	-	-	114
SAE D, 2 hole	135	21x37x8	M20	385	540	228.6	-	-	-
SAE D, 2 hole with 4 additional threads M16	135	21x37x8	M20	385	540	228.6	-	-	138
SAE D 2 hole with additional bolt holes (d=17.5mm)	135 & 165	21x37x8	M20	385	540	228.6	230	190	-
SAE E, 4 hole	210 & 280	-	M20	385	540	224.5	-	-	-

*) Option for standard design, necessary for tandem units

2-hole flange

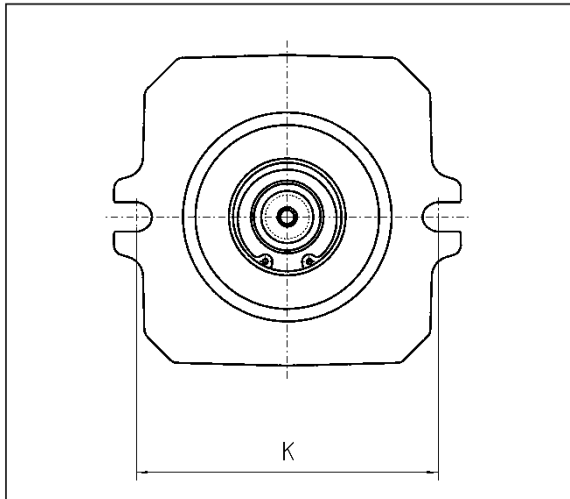

4-hole flange

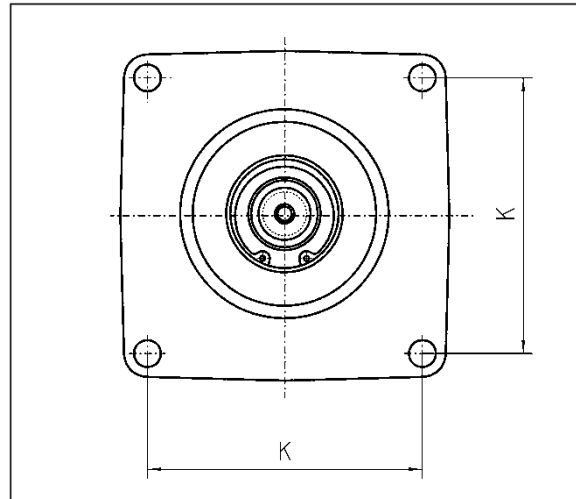

2-hole flange
with 4 additional threaded holes

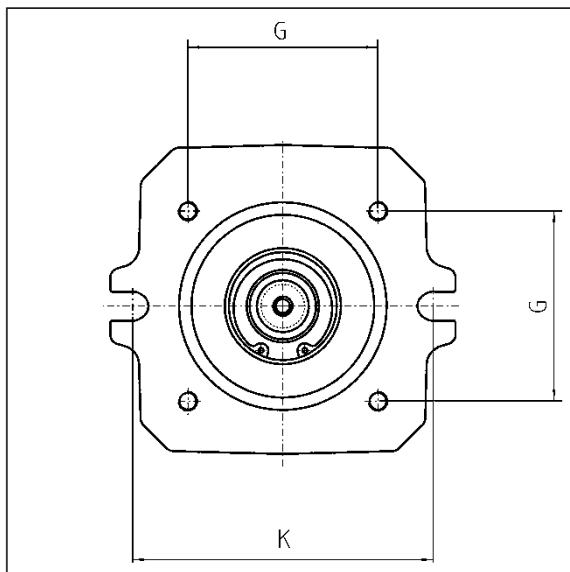

2-hole flange
with 4 additional bolt holes

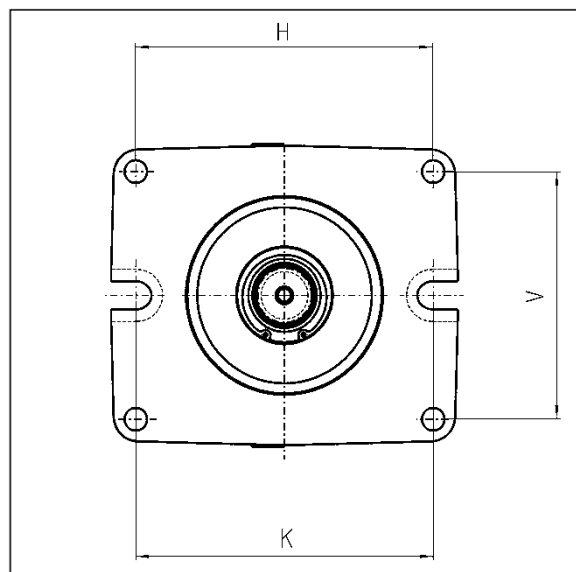

TORQUE TRANSMISSION. DRIVE SHAFT

A) Dimensions ANSI and SAE drive shafts

Shaft spline (in accordance with ANSI B92.1)	SAE-J744 code (for centring and shaft)	Outside diameter [mm]	Useable spline length [mm]	Shaft type	Available for rated size						
					55	75	105	135	165	210	280
12/24, 14 t	C	31.22	30	2	x	x	x				
16/32, 21 t		34.51	39.5	1	x*	x*					
12/24, 17 t	C-C	37.68	30	2			x	x			
16/32, 23 t		37.68	38.5	1			x*				
8/16, 13 t	D, E	43.71	50	2				x	x		
16/32, 27 t		44.05	62	1				x	x*	x	
8/16, 15 t	F	50.06	58	1						x*	x
16/32, 33 t		53.57	58	1							x*

*) Recommended for tandem configurations

A) Maximum input torque

Rated size		55	75	105	135	165	210	280
Shaft		16/32 21 t	16/32 21 t	16/32 23 t	16/32 27 t	16/32 27 t	8/16 15 t	16/32 33 t
Continuous torque	Nm	435	604	836	1080	1318	1672	2243
Maximum torque	Nm	649	900	1245	1609	1964	2491	3343
Excess length	mm	54	55	55	75	75	75	75

A) Linde Hydraulics shaft types

Type 1. Without undercut

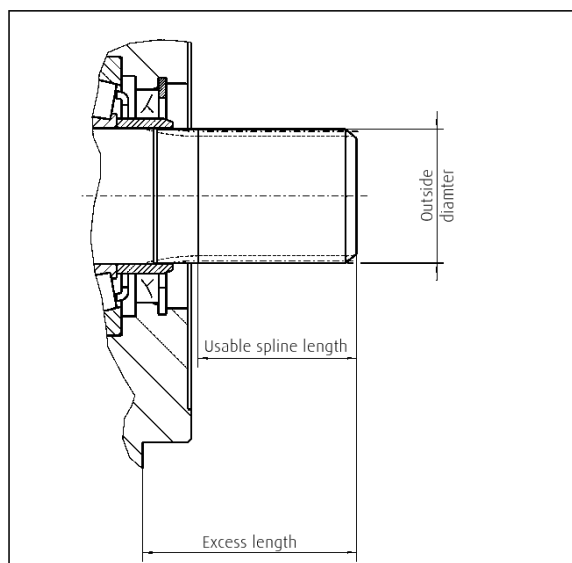

Type 2. With undercut

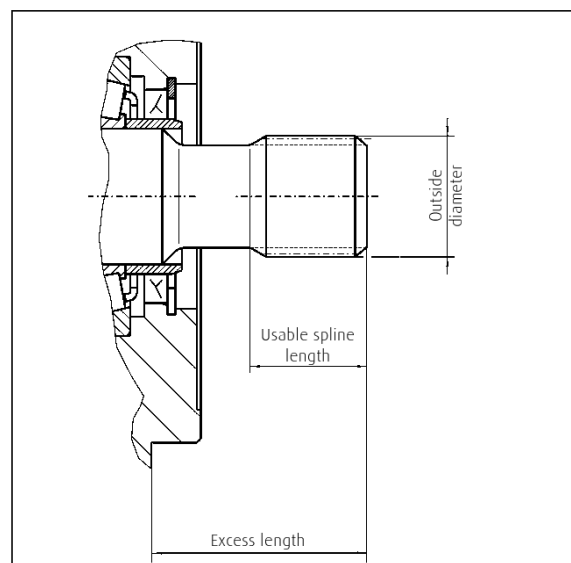

TORQUE TRANSMISSION. PTO FLANGE

Linde pumps can be combined into tandem and multiple pumps. The combination options are determined by the permitted transfer torque. The following data refers to the PTO (pump output side, without further attachments).

B) PTO dimensions

Rated size		55	75	105	135	165	210	280
Z Drive hub profile in accordance with ANSI B92.1		16/32, 15 t	16/32, 18 t	16/32, 19 t	16/32, 21 t	16/32, 22 t	16/32, 24 t	16/32, 27 t
D1	mm	40	42	48	52	63	63	72
D2 spigot pilot diameter	mm	82.55						
D3	mm	88				89.5	89.5	
D4	mm	M 10						M12
D5 max. bearing clearance	mm	30	35	38	43	44.5	47	49
L1	mm	1.5				1.9		
L2 adapter length	mm	7				8		
L3	mm	9						
L4 minimum distance	mm	35	39	33	35	37	38.5	50.5
L5 usable spline length	mm	14	18	19	20	25	29	30.6
L6 distance to bearing	mm	51	57.5	53	55.9	63.1	68.3	83
L7 min. bearing clearance	mm	3	3	3	4	3	3	-
L8 hole distance 2-hole	mm	106.4						146

B) Output shaft transfer torque

Rated size		55	75	105	135	165	210	280
Continuous transfer torque	Nm	218	302	418	540	659	836	1122
Max. transfer torque	Nm	431	598	763	1069	1305	1655	2221

Torque transmission. Output shaft

B) PTO dimensions

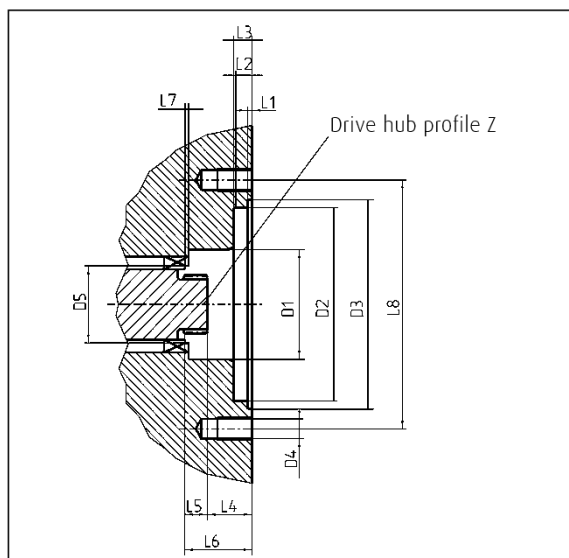

GEAR PUMPS.

Two types of gear pumps are available: internal gear pump IGP and external gear pump EGP. The possible combinations of and with IGP and EGP are determined by the PTO option and the permitted shaft torque. Both types can be used as charge pump for the main circuit or the control and cooling circuit. The allowable pressure at the suction port is between 0.8 bar (abs.) and 3.0 bar (abs.). The charge pressure relief valves for the rated sizes 55-135 are integrated in the port plate housing, and for the rated sizes 165-280 in the charge pressure manifold of the HPV-02.

Technical data

Displacement volume	cc/rev	16	19	22.5	31	38	44
Standard charge pump for HPV-02	Rated size	55-105		75-135	165	210	280
Type of gear pump		IGP	EGP	IGP	EGP	EGP	EGP
Mounting flange and drive shaft profile		SAE A 16/32, 18 t	SAE A 16/32, 9 t	SAE A 16/32, 18 t	SAE A 16/32, 9 t	SAE A 16/32, 13 t	SAE A 16/32, 13 t
Type of suction		internal, external	external	internal, external	external	external	external
Max. perm. operating pressure <small>observe max. permissible rated pressures for filter and cooler</small>	bar	40	210	40	165	275	220
Standard PTO flange and shaft spline		SAE A 16/32, 9 t	-	SAE A 16/32, 9 t	-	-	-
Continuous output torque	Nm	175 <small>75 Nm with SAE A</small>	-	175 <small>75 Nm with SAE A</small>	-	-	-
Max. output torque	Nm	250 <small>107 Nm with SAE A</small>	-	250 <small>107 Nm with SAE A</small>	-	-	-
Cold start relief valve		integrated	-	integrated	-	-	-

External gear pump EGP

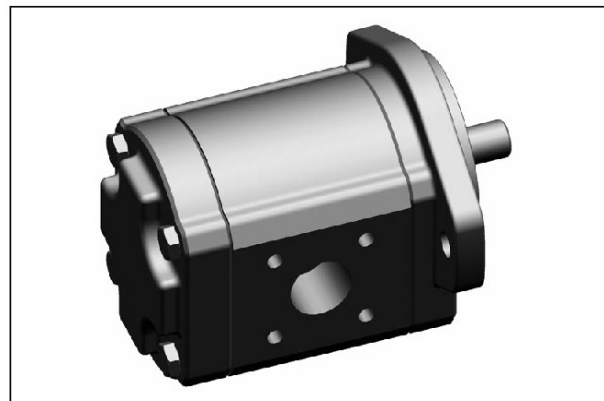
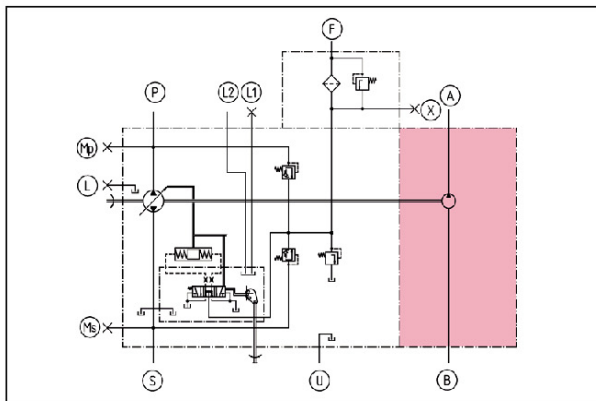

GEAR PUMPS.

The IGP charge pumps include a cold start relief valve and a through drive for attaching additional pumps. The suction can be internal, external or combined. IGP types are available in rated sizes of 16 cc/rev and 22.5 cc/rev.

Internal gear pump IGP with internal suction

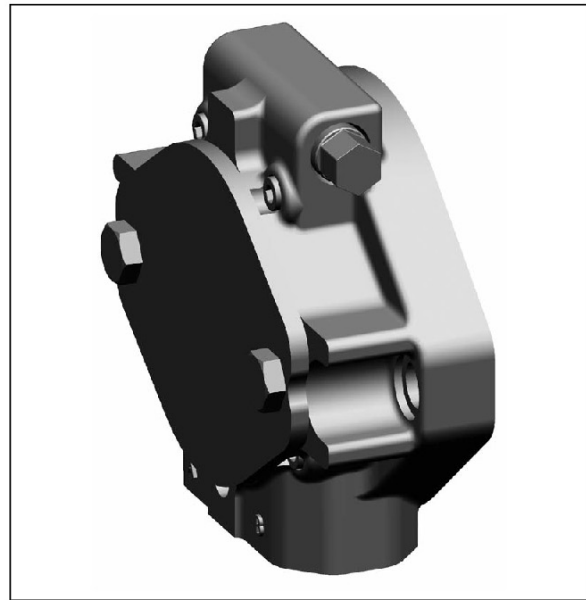
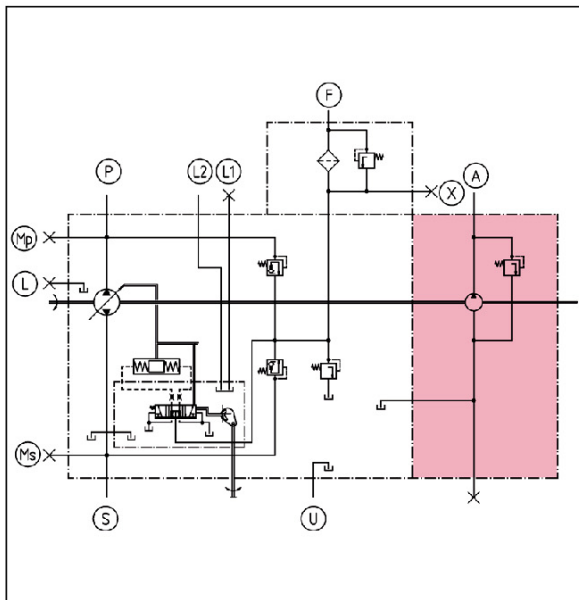

Internal suction

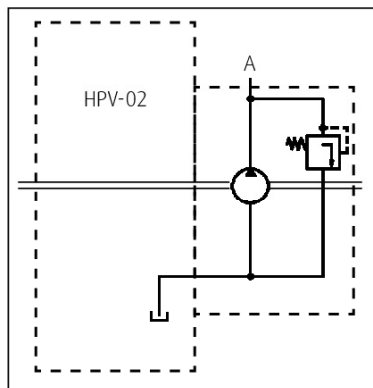

External suction

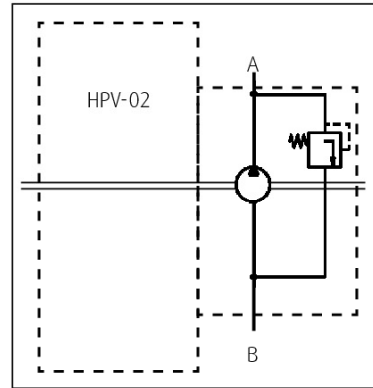

Combined suction

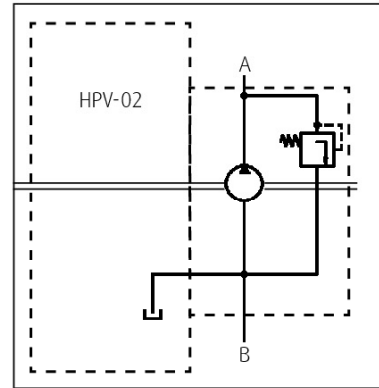

>> Internal suction

The charge pump supplies the main circuit with oil from the pump housing.
External connection B is closed.

>> External suction

The charge pump supplies the main circuit with oil from the oil tank.
The internal connection is closed.

>> Combined suction

The charge pump supplies the main circuit with oil from the pump housing and oil tank.
This type of suction is a combination of internal and external suction.

GEAR PUMPS.

PTO flange with IGP

Flange profile 2-hole		SAE A	SAE B	SAE B-B	SAE C
Z Internal drive hub profile in accordance with ANSI B92.1		16/32, 9 t	16/32, 13 t	16/32, 15 t	12/24, 14 t
D1 Spigot pilot diameter	mm	82.55	101.6		127
D2 Thread size	mm	M 10	M 12		M 16
L1 Hole distance	mm	106.4	146		181
L2 Adapter length	mm	7	11		13
L3 Flange length	mm	-	55		72
Continuous transfer torque	Nm	75	175		
Maximum transfer torque	Nm	107	250		

PTO SAE A with IGP

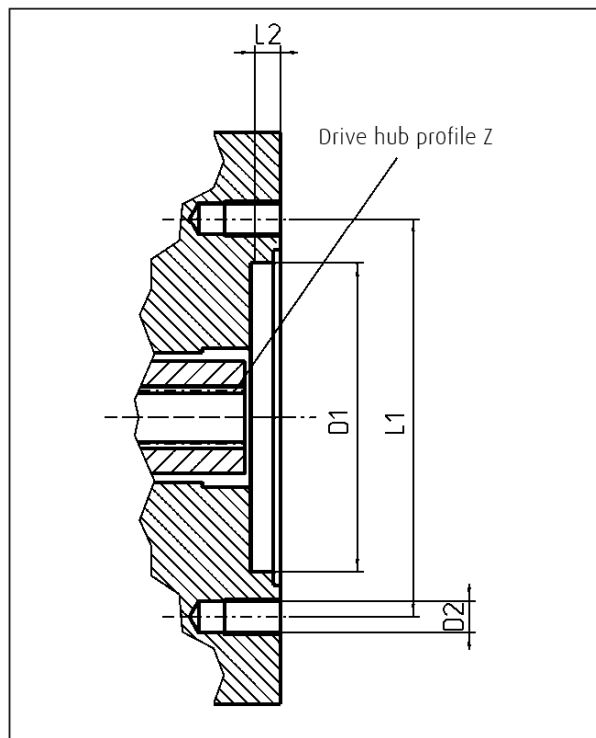

PTO SAE B, B-B and C with IGP

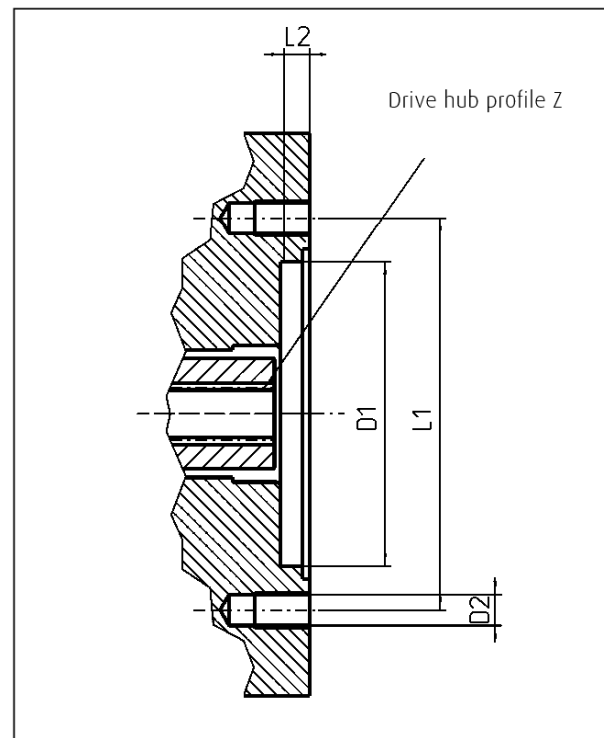

CONTROLS.

The modular control concept with standardised interface enables quick selection and adaptation for different customer and system requirements with mechanical, hydraulic or electronic control. All Series 02-controls feature an upstream signal circuit that is adapted to the respective control, and a standardised and load-independent servo control for simple and constantly available machine or vehicle control.

Technical data

Type of control	Additional option	Name of control
Mechanical	proportional	M1R
Hydraulic	proportional	H1
	with pressure cut-off regulation	H1P
	speed dependent	CA
	torque-/power controlled	CA
	with additional safety function	CA
Electrical	proportional	E1
	with pressure cut-off regulation	E1P
	with additional safety function	E2
	3 position	E5

E1/E5-control

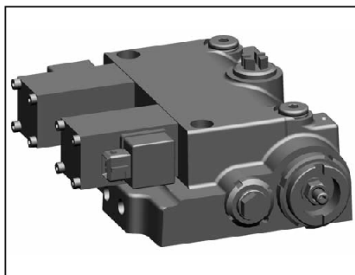

E1P-control

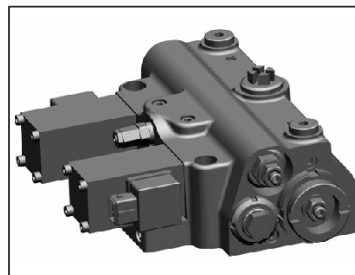

E2-control

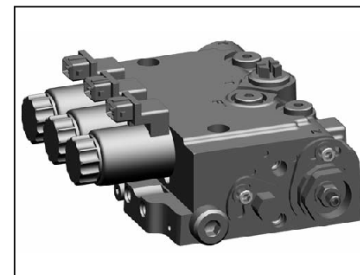

H1-control

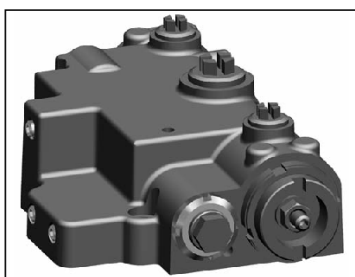

H1P-control

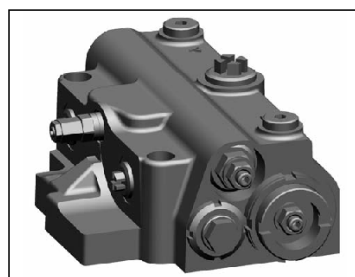

CA-control

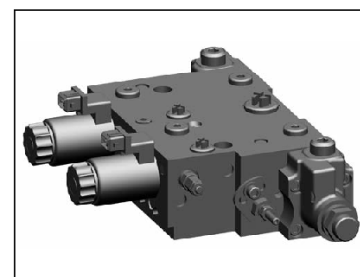

M1R-control

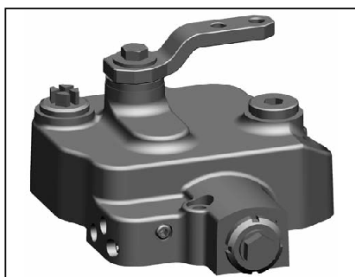

HPV-02 E2

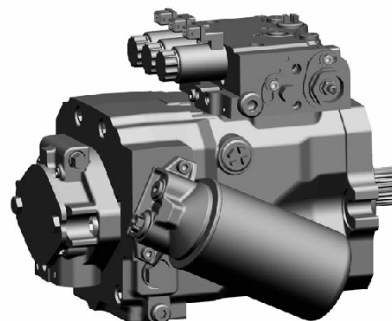

CONTROLS. CONTROL ACCURACY

All Series 02-pump controls result in the same machine response for identical motion commands, irrespective of the control type. Corrective action by the operator is no longer required. The reliable control of the pump can easily be integrated into any kind of vehicle management control system.

Control accuracy of a HPV-02 pump

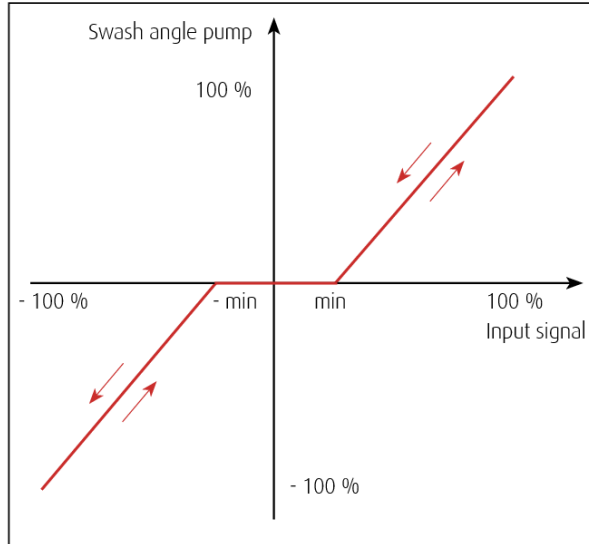

E2-control

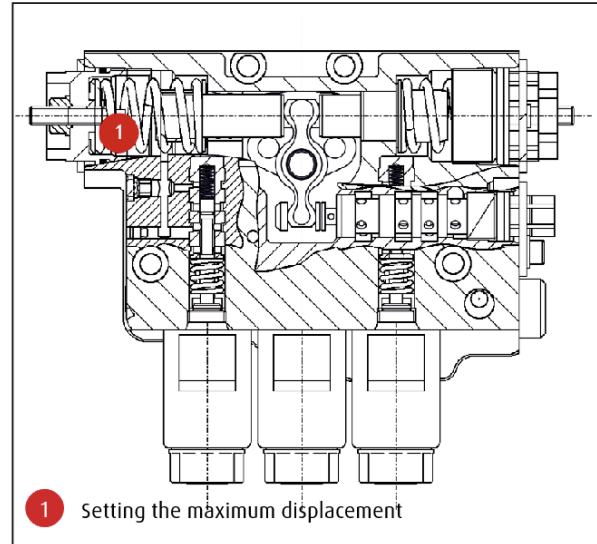

Pressure cut-off regulation PCO

Special control elements deal with functions such as torque control or pressure cut-off regulation. Controls with pressure cut-off regulation (PCO) reduce pump flow when the cut-off pressure is reached. Because system pressure is maintained at low flow, the power consumption and thermal balance of the system are optimised.

Displacement relative to pilot pressure and pressure cut-off regulation for H- and E-controls

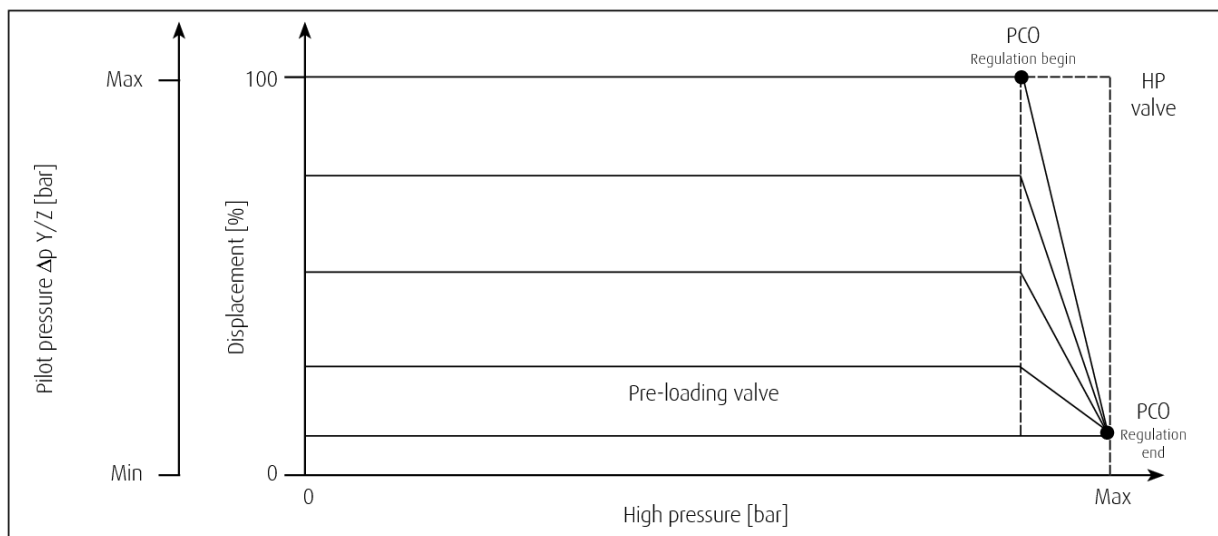

CONTROLS. MECHANICAL-HYDRAULIC M

The M1R-pump control combines robustness with high precision for direct and reliable machine control. It is mechanically controlled and can be combined with a fixed, variable or regulating hydraulic motor. The control-specific data is independent of the nominal pump size.

M1R Mechanical control

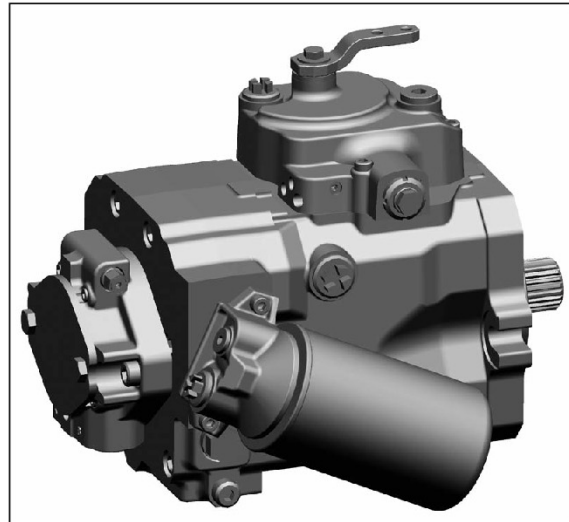
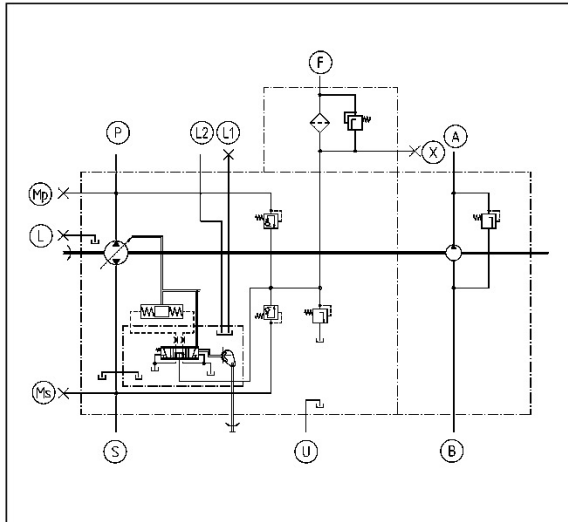

Flow direction

By turning the control lever the pump flow rate and direction of flow are controlled via a cam plate. The flow direction of the fluid depends on

- >> the pump direction of rotation
- >> the over centre direction of the swash plate.

High pressure outlet port

		Shaft rotation (view on Z)	
Cam lever direction		Right hand	Left hand
	0 → 1	P	S
	0 → 2	S	P

- P, S High pressure ports
- A Pressure port, charge pump
- B Suction port, charge pump
- F Feed port, charge and control
- X Test port, control pressure
- Ms, Mp Test ports, high pressure
- L, U Drain ports
- L1, L2 Vent ports

- Note for left hand rotation**
- A Suction port, charge pump
 - B Pressure port, charge pump



CONTROLS. MECHANICAL-HYDRAULIC M

The cam plate offers a large control angle with progressive control characteristic and a wide neutral range. The resulting high resolution for movements from the neutral range (and vice versa) enables precise manoeuvring. Reliable and robust control of the displacement volume is achieved through position feedback.

Displacement relative to control angle

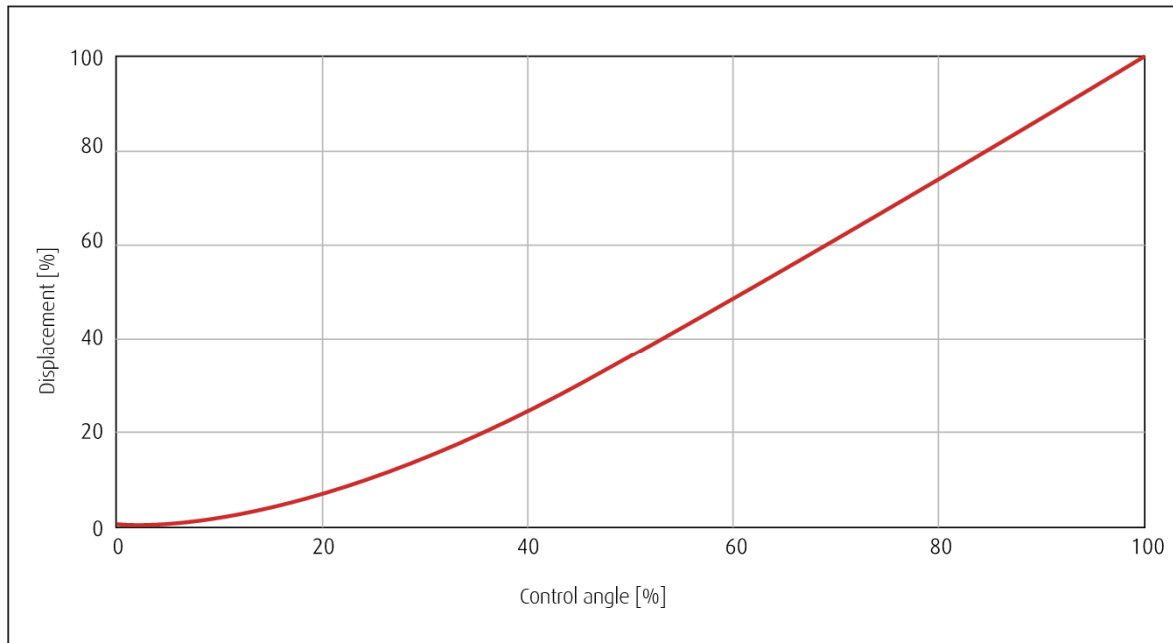

Control force with max. long lever radius $r = 70$ mm	17 N
Max. permissible control force (intermittent)	500 N
Control torque	< 1.0 Nm
Control torque out of notch	< 1.5 Nm
Neutral position	24°, 90° (standard), 133°, 144°, 188°, 210°, 232°
Control angle neutral range ... to end position	$\pm 3^\circ$... $\pm 48^\circ$
Minimum response time with standard restrictors	0.5 s

M1R-cam plate

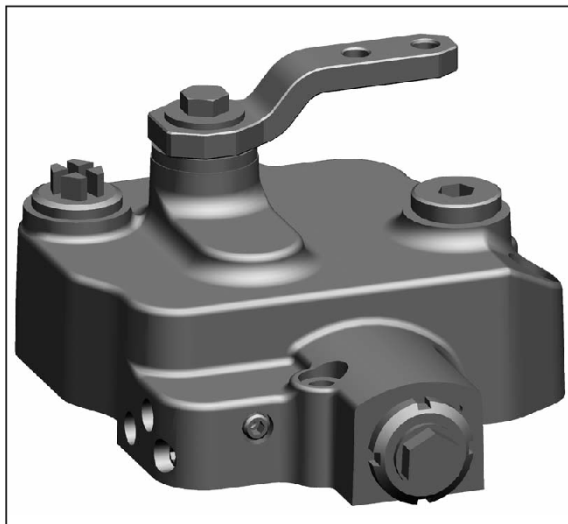

Control range

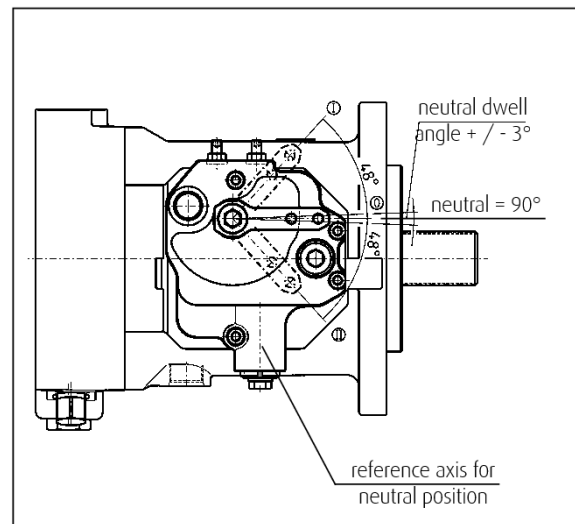

CONTROLS. HYDRAULIC H

The HPV-02 H1 features hydraulic control with a wide pilot pressure range for improved machine control. It can be combined with a fixed, variable or regulating hydraulic motor. The data is specific for hydraulic controls, and independent of the nominal pump size and pressure cut-off regulation PCO, unless specified otherwise otherwise (see section Controls. Control accuracy).

H1. Hydraulic control

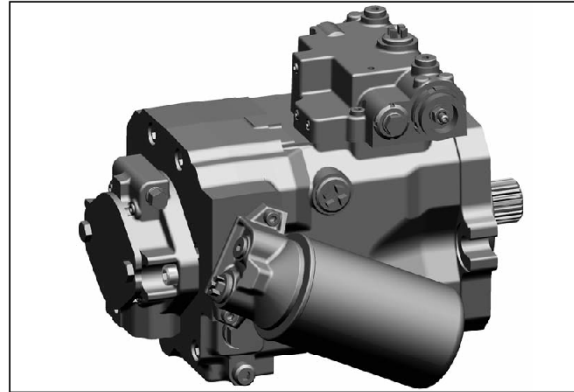
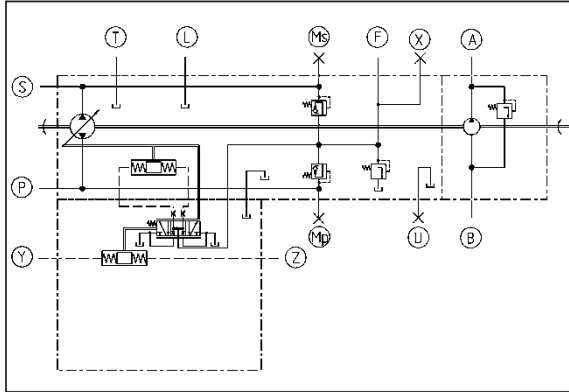

Flow direction

By an external hydraulic signal input at the pilot pressure ports (Y, Z) the pump flow rate and direction of flow are controlled. The flow direction of the fluid depends on the pump direction of rotation and the over centre direction of the swash plate.

High pressure outlet port

	Shaft rotation (view on Z)		
Pilot pressure port		Right hand	Left hand
	Y	P	S
	Z	S	P

H1P. Hydraulic control with PCO

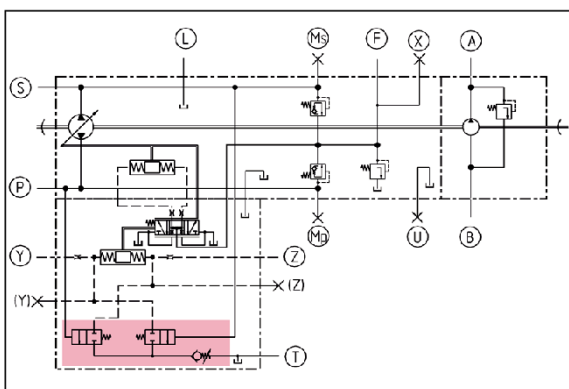

- P, S High pressure ports
- A Pressure port, charge pump
- B Suction port, charge pump
- F Feed port, charge and control
- X Test port, pilot pressure
- Ms, Mp Test ports, high pressure
- L, U Drain ports
- T Vent port
- Y, Z Pilot pressure ports

Note for left hand rotation

- A Suction port, charge pump
- B Pressure port, charge pump



CONTROLS. HYDRAULIC H

Pilot pressure range	standard: 4-16 bar, option: 4-10 bar differential pressure [Y-Z]
Maximum permissible pressure at Y or Z	30 bar
Minimum response time with standard orifices for one-way swashing between 0 and max	0.5 s

Displacement relative to pilot pressure

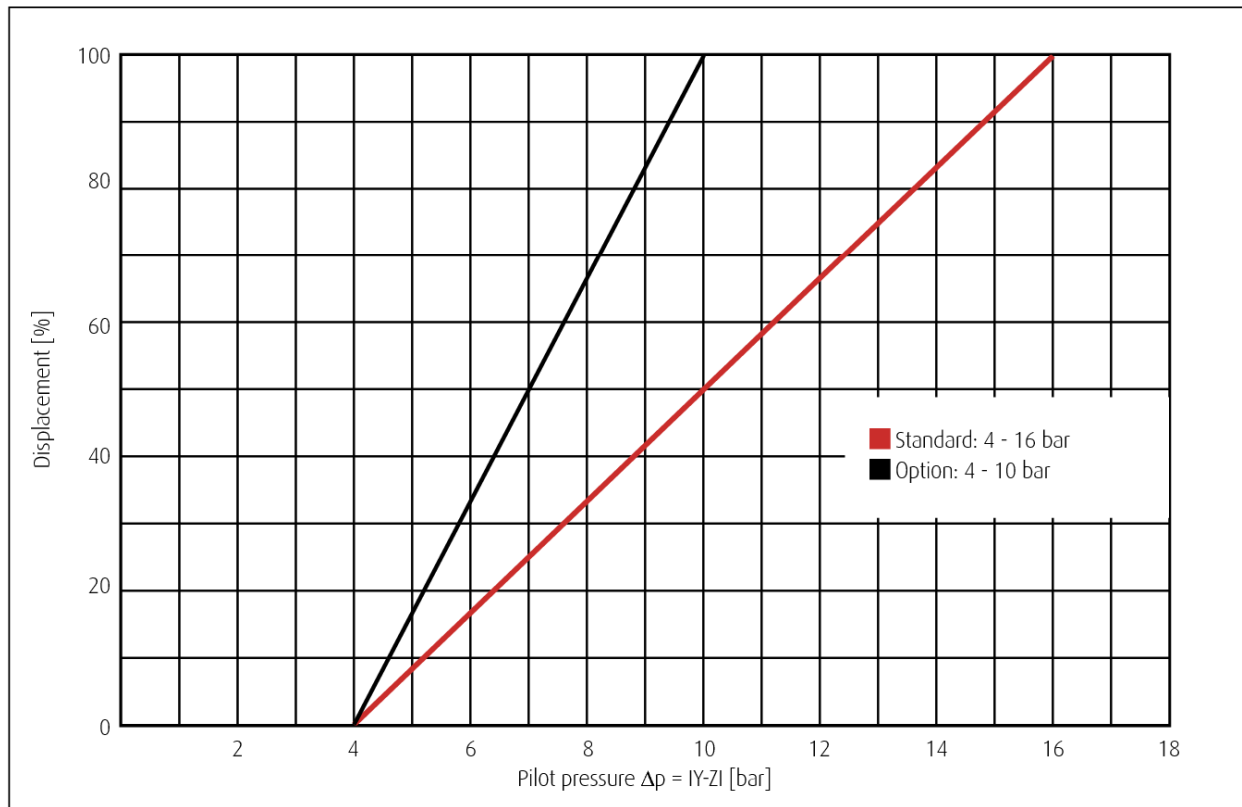

H1P-control with PCO

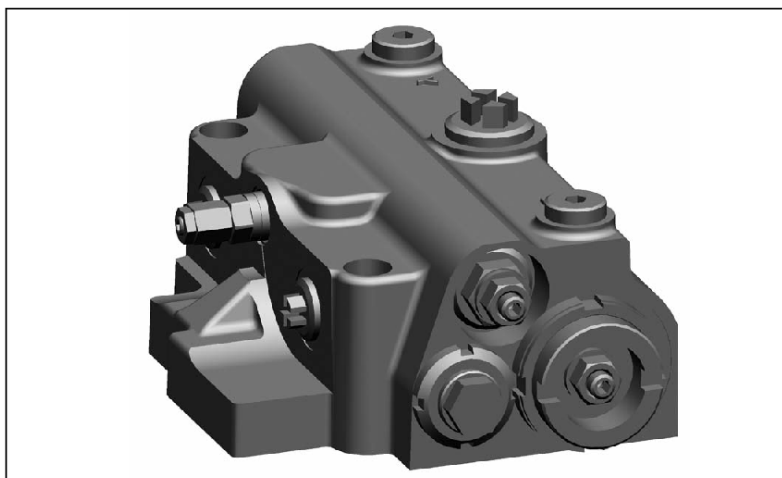

CONTROLS. HYDRAULIC-MECHANICAL CA

The HPV-02 CA is a speed-dependent pump control with torque/power regulation. It can be combined with a hydraulic motor as fixed, variable or regulating motor or a variable motor with pressure regulator. The modular design offers a high degree of versatility in terms of function and control.

CA. Hydraulic-mechanical control

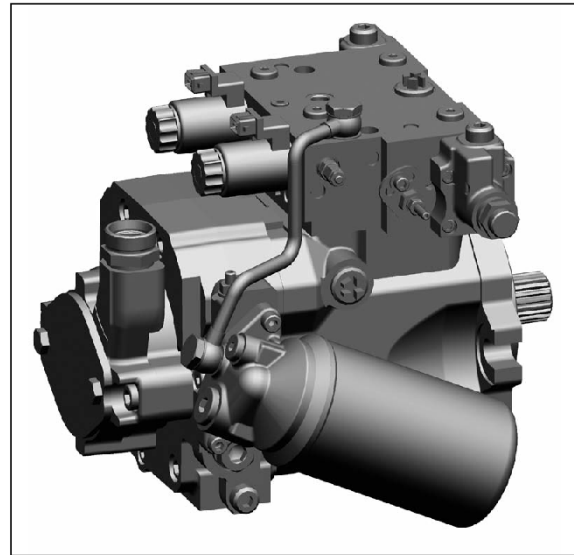
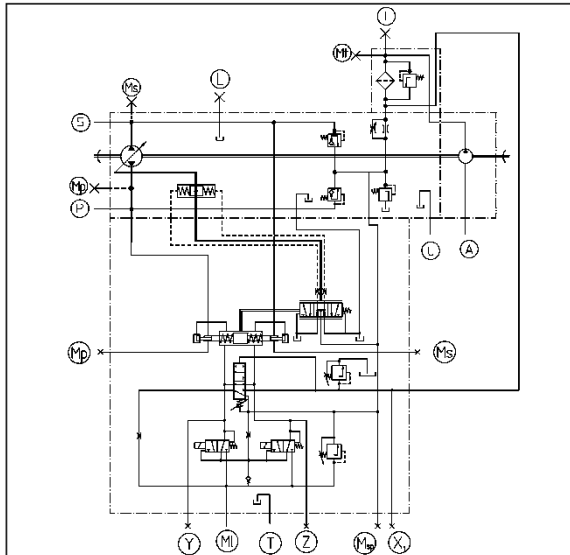

CA-control. Advantages

- >> pilot operated system
- >> controlled load response
- >> temperature independent
- >> dynamics
- >> precision
- >> low hysteresis
- >> high versatility (modular design)
- >> various motor control possible
- >> simple adjusting
- >> direct control of torque and tractive force
- >> speed optimized inching function
- >> high safety standard
- >> hydrostatic deceleration

- P, S High pressure ports
- A Suction port, charge pump
- F Feed port, charge and control

Test ports

- Mt Temperature
- Ms, Mp High pressure
- Y, Z Pilot pressure
- Ml For power settings and inch pressure port
- Msp Charge pressure
- X Pilot pressure port HMV
- L, U Drain ports
- L1, L2 Vent ports
- T Drain and vent port

Note for left hand rotation

- A Suction port, charge pump

Drive with speed-dependent variable pump and variable motor with pressure override

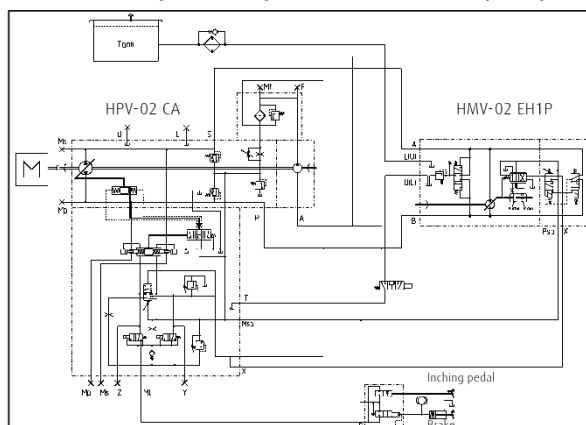

Not every component shown is part of the Linde product portfolio.



CONTROLS. ELECTRO-HYDRAULIC E1 AND E5

The HPV-02 E1 has two proportional solenoids and through the upstream signal circuit it combines the flexibility of electronic vehicle management with the reliability of a pump control marked by its high operational availability. Precise and simple. Identical commands always call for the same response in the machine, so no corrective action is required by the operator or the electronic system. The HPV-02 E5 has two switching solenoids and thus sets the pump to either neutral or maximum swash angle of any direction.

E1. Electro-hydraulic control

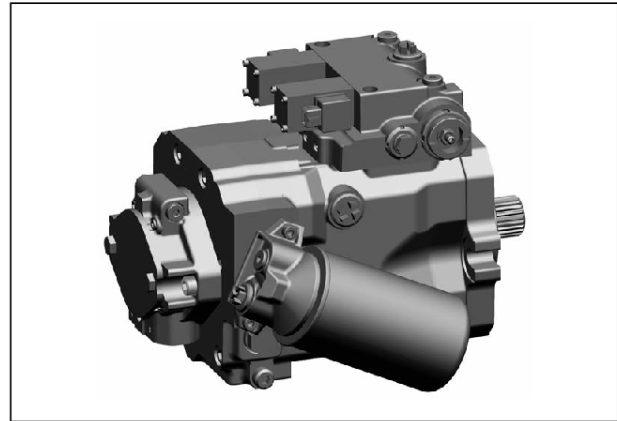
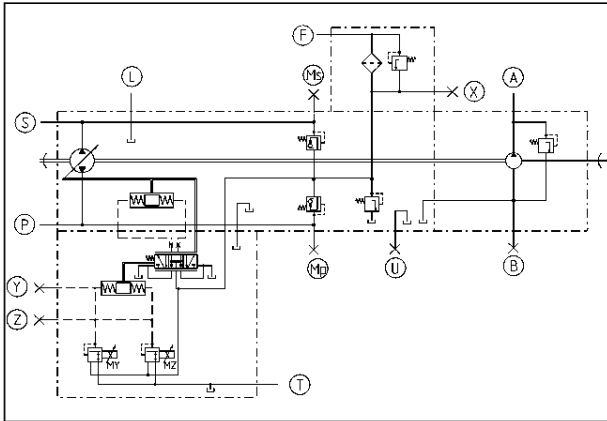

E1P. Electro-hydraulic control with PCO

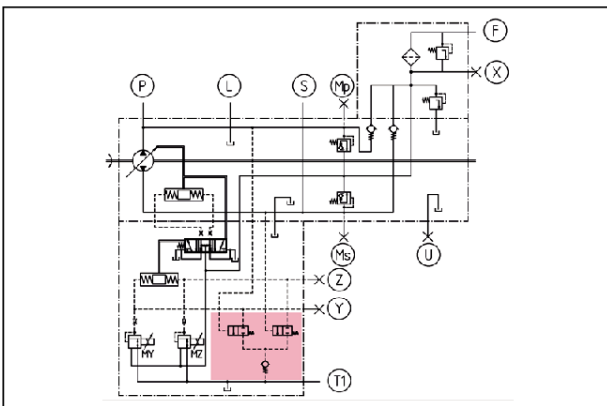

E5. Electro-hydraulic 3 position control

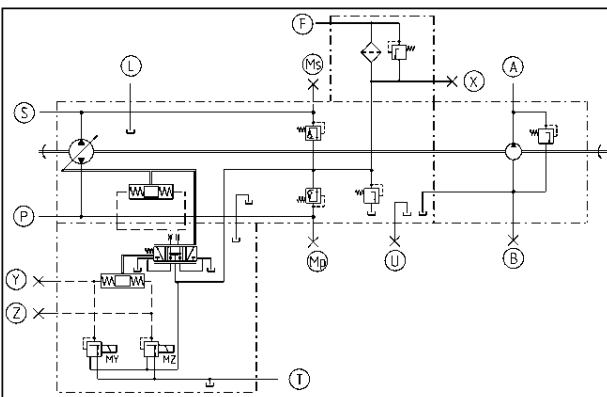

- P, S High pressure ports
- A Pressure port, charge pump
- B Suction port, charge pump
- F Feed port, charge and control
- X Test port, pilot pressure
- Ms, Mp Test ports, high pressure
- L, U Drain ports
- T Vent ports

Note for left hand rotation

- A Suction port, charge pump
- B Pressure port, charge pump



CONTROLS. ELECTRO-HYDRAULIC E2

The HPV-02 E2, with its additional release function, can easily be integrated in an electronic vehicle management control system like an E1-control. In addition it offers a safety standard that meets the stringent requirements for road traffic use. The E2-control features two proportional solenoids and a switching solenoid.

E2. Electro-hydraulic control

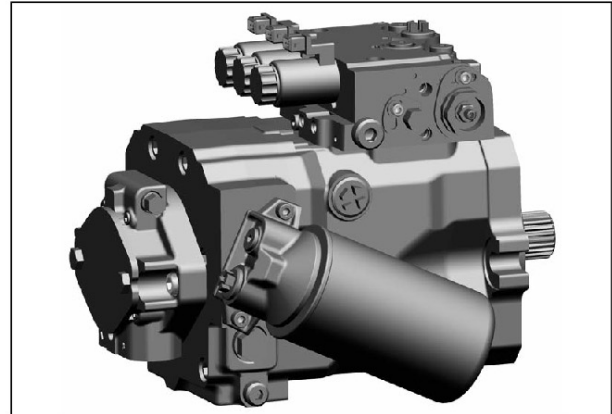
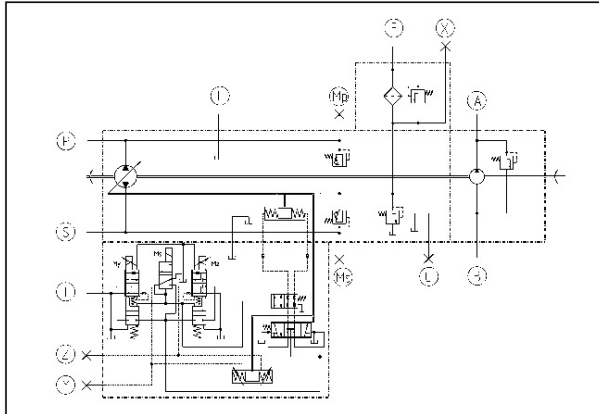

E2 with switch-off function

The E2 control offers an interface for switching off the whole system. In case of signal irregularity or perturbation like cable break or short-circuit in the switching solenoid circuit (co called 'watchdog'), the pump swashes back to neutral position in a defined manner.

The vehicle is decelerated until standstill and thus provides a safe condition of the machine as per EN ISO 13849.

In case of disfunction in the proportional magnets' circuits, a similar reaction can be induced by the intervention of the electronic control units.

Its use is recommended for mobile applications where specific safety criteria have to be met in terms of travel and coasting behaviour, e.g. road traffic use.

Product advantages of E2

- >> fulfils the rigorous demands for road traffic use
- >> active drive enable
- >> minimized susceptibility to interference
- >> with HMF-02: defined swashing back of pump for controlled deceleration and stop in case of system fault
- >> with HMV-02: diesel overspeed protection by fast swashing back of pump

P, S	High pressure ports
A	Pressure port, charge pump
B	Suction port, charge pump
F	Feed port, charge and control
X	Test port, control pressure
Ms, Mp	Test ports, high pressure
Y, Z	Test ports, control pressure
L, U	Drain ports
T	Vent port

Note for left hand rotation

A	Suction port, charge pump
B	Pressure port, charge pump

CONTROLS. ELECTRO-HYDRAULIC E

E1 control

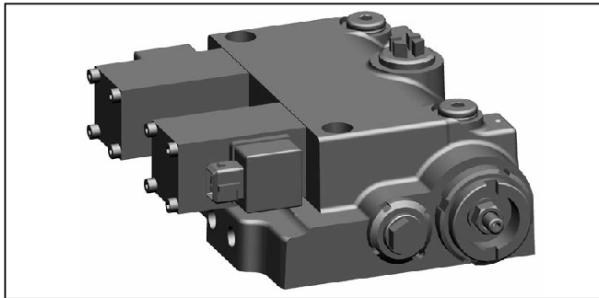

E1P control

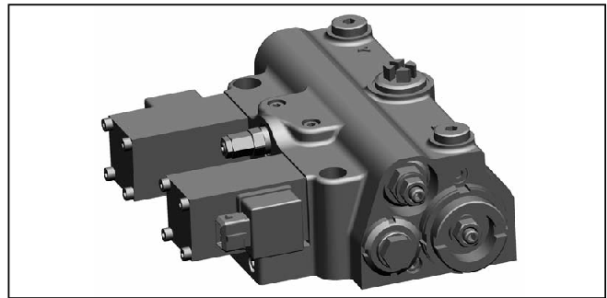

E5 control

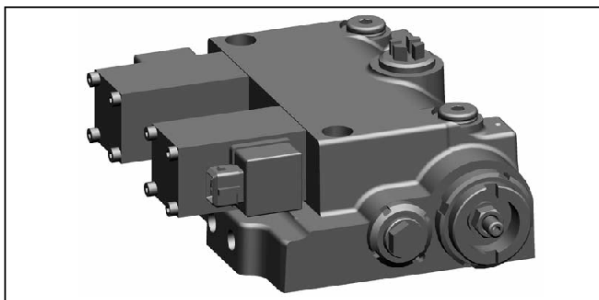

E2 control

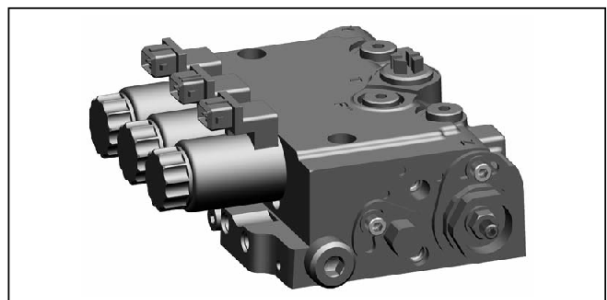

Flow direction

By an external electrical signal input at the solenoids (MY and MZ) the pump flow rate and direction of flow are controlled. The flow direction of the fluid depends on

- >> the pump direction of rotation
- >> the over centre direction of the swash plate.

High pressure outlet port

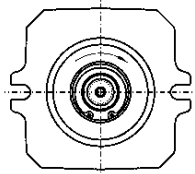
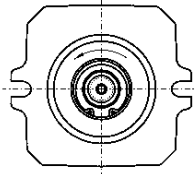
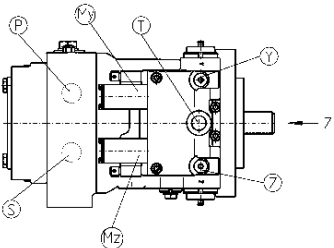
	Shaft rotation (view on Z)		
Active solenoid		Right hand	Left hand
	MY	P	S
	MZ	S	P

CONTROLS. ELECTRO-HYDRAULIC E

The data is specific for electrical controls, and independent of the nominal pump size and PCO pressure cut-off regulation, unless specified otherwise (see section Controls. Control accuracy). Figures HPV-02 E1 and HPV-02 E2 (page 22, 23) show the standard mounting position for the respective E-control.

Control signal characteristics

Supply voltage = limiting voltage		V	12	24
Connector type			DIN EN 175301-803, Deutsch, AMP Junior Timer (2-pin*)	
Voltage type			Direct Current (D.C.)	
Power consumption		W	15.6	
Rated current = limiting current		mA	1300	650
Control current	swash begin	mA	450 ± 10	225 ± 5
	swash end on request	pilot pressure range 4-10 bar (option)	mA	810
		pilot pressure range 4-16 bar (standard)	mA	1200
Relative duty cycle		%	100	
Protection class			IP54 (DIN), IP67 (Deutsch), IP6K6K (AMP)	
Control types	digital control via Pulse Width Modulation PWM		100 Hz rectangle, pulse duty ratio variable over control range	
	analogue control		Direct current with dither overlay (dither frequency nom. 35 Hz, duty cycle 1:1). Further details on request	
Minimum response time with standard orifices		s	0.5	

*) Coding 1 with proportional solenoids (E1, E1P), coding 2 with switching solenoids (E2, E5)

Displacement relative to control current

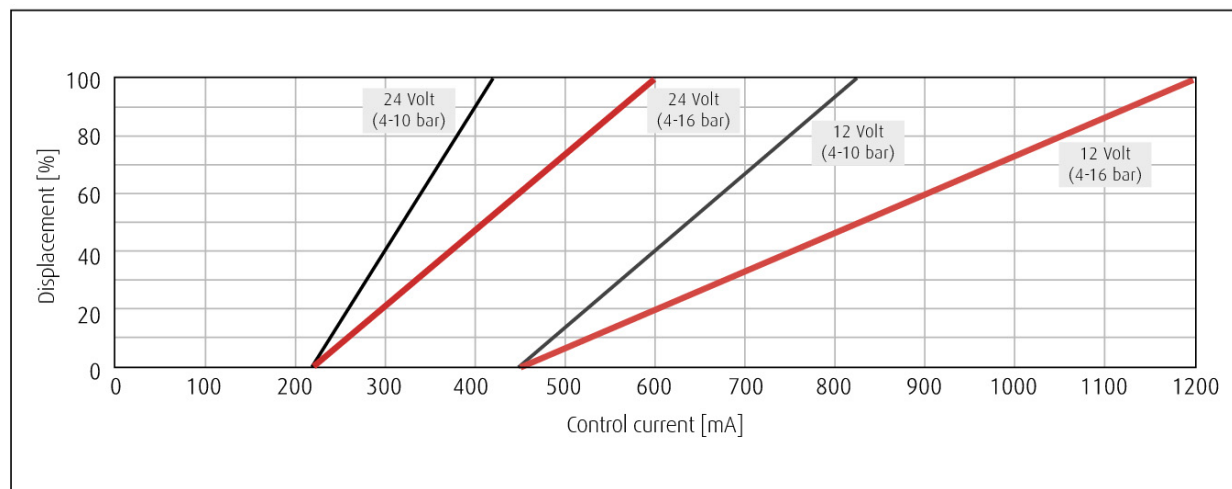

DIMENSIONS. M-CONTROLS

Control-specific dimensions for HPV-02 with mechanical-hydraulic controls.

Port sizes and dimensions for M-controls

Rated size	55	75	105	135	165	210	280
D1 [mm]	127		152.4		165.1		
B1 [mm]	181		228.6		224	225	
B2 [mm]	101	116		141	141	142	155
B3 [mm]	101	116		141	138.5	135	-
B4 [mm]	192	216		219	233	240	246
B5 [mm]	194						
L1 [mm]	225	242	267	288	319.5	346	392
L2 [mm]	282	304	329	350	485.5	516	571
L3 [mm]	335	359	385	425	560.4	591	646
L4 [mm]	151						
L5 [mm]	70						
L6 [mm]	48						
H1 [mm]	88	93	99	106	119.5	134	152
H2 [mm]	95	103	105	112	122.5	133	150
H3 [mm]	184	188	193	198	214.5	226	238
P	SAE 3/4"	SAE 1"		SAE 1 1/4"		SAE 1 1/2"	
S	SAE 3/4"	SAE 1"		SAE 1 1/4"		SAE 1 1/2"	
A gear pump	M27x2			SAE 1"		SAE 3/4"	
B gear pump	M36x2			SAE 1 1/4"		SAE 1 1/4"	
L	M22x1.5			M27x2		M27x2	M33x2
U	M22x1.5			M27x2		M27x2	M33x2
F	M22x1.5			M27x2			
X	M14x1.5						
Mp	M14x1.5						
Ms	M14x1.5						
L1	M22x1.5						
L2	M22x1.5						

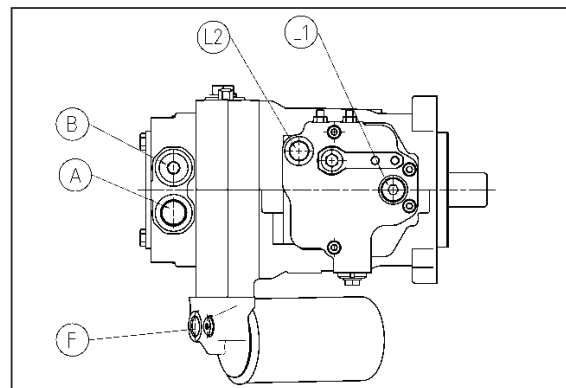
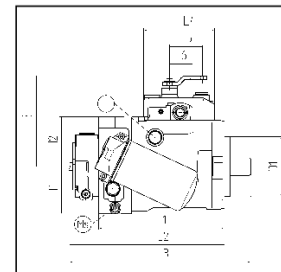
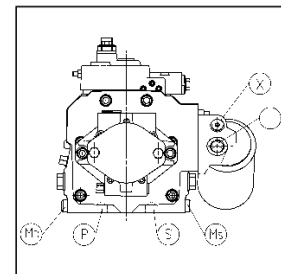
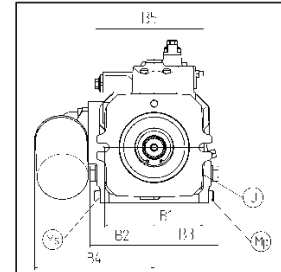

Threads metric in accordance with ISO 6149-1
 Suction port at IGP in accordance with ISO 8434-1 L28
 High pressure ports similar to ISO 6162-2
 Socket cap screw in accordance with ISO 4762
 Further threads on request

DIMENSIONS. H-CONTROLS

Control-specific dimensions for HPV-02 with hydraulic controls.

Port sizes and dimensions for H-controls

Rated size	55	75	105	135	165	210	280
D1 [mm]	127		152.4		165.1		
B1 [mm]	181		228.6		224	225	
B2 [mm]	101	116		141	134.5	143	155
B3 [mm]	101	116		141	134.5	135	139
B4 [mm]	192	216		219	233	240	246
B5 [mm]	231						
L1 [mm]	225	242	267	288	319.5	346	392
L2 [mm]	282	304	329	350	485.5	516	571
L3 [mm]	335	359	385	425	560.4	591	646
L4 [mm]	133						
H1 [mm]	88	93	99	106	119.5	134	152
H2 [mm]	95	103	105	112	122.5	133	150
H3 [mm]	w/o PCO	194	154	158	163	187	204
	with PCO	185	190	194	199	223	201
P	SAE ¾"		SAE 1"		SAE 1 ¼"		SAE 1 ½"
S	SAE ¾"		SAE 1"		SAE 1 ¼"		SAE 1 ½"
A gear pump	M27x2				SAE 1"		SAE ¾"
B gear pump	M36x2				SAE 1 ¼"		SAE 1 ¼"
L	M22x1.5			M27x2			M33x2
U	M22x1.5			M27x2			M33x2
F	M22x1.5			M27x2			M27x2
T	M22x1.5						
X	M14x1.5						
Mp	M14x1.5						
Ms	M14x1.5						
Y	M14x1.5						
Z	M14x1.5						

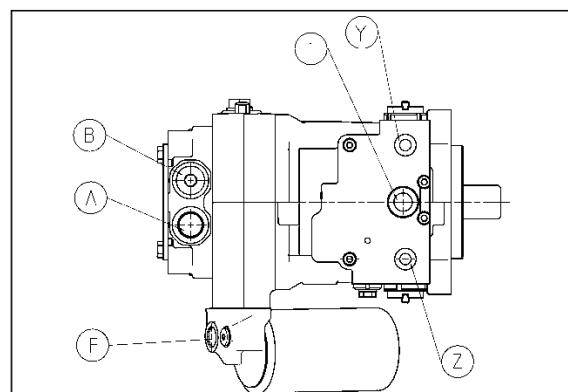
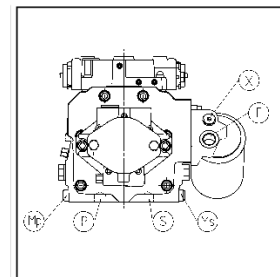
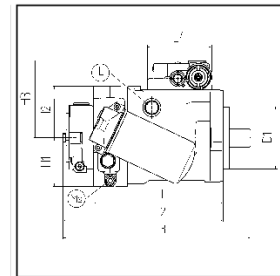
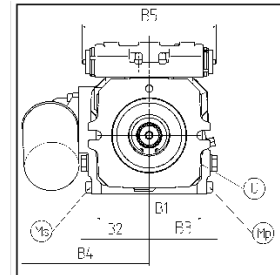

Threads metric in accordance with ISO 6149-1
 Suction port at IGP in accordance with ISO 8434-1 L28
 High pressure ports similar to ISO 6162-2
 Socket cap screw in accordance with ISO 4762
 Further threads on request

DIMENSIONS. CA-CONTROLS

Control-specific dimensions for HPV-02 with hydraulic-mechanical controls.

Port sizes and dimensions for CA-controls

Rated size	55	75	105	135
D1 [mm]		127		152.4
B1 [mm]		181		228.6
B2 [mm]	101	116		141
B3 [mm]	101	116		141
B4 [mm]	193	212	214	217
B5 [mm]		336		
L1 [mm]	225	242	267	288
L2 [mm]	282	306	331	351.5
L3 [mm]	343	361	386.3	426.1
L4 [mm]		207		
H1 [mm]	88	93	99	105.5
H2 [mm]	95	103	99	104
H3 [mm]	178	184	187.8	191.1
A gear pump		M36x2		
P		SAE 1"		
S		SAE 1"		
L		M22x1.5		
U		M22x1.5		
F		M22x1.5		
T		M22x1.5		
X1		M14x1.5		
Mp		M14x1.5		
MI		M14x1.5		
Ms		M14x1.5		
Msp		M14x1.5		
Mt		M14x1.5		
Y		M14x1.5		
Z		M14x1.5		

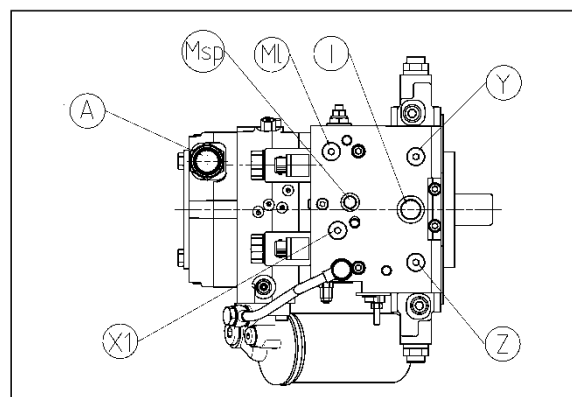
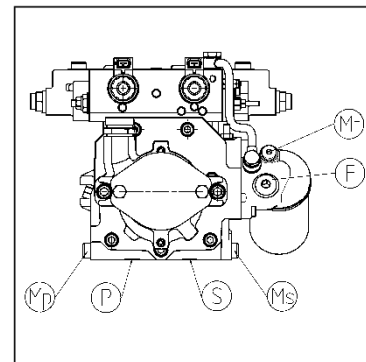
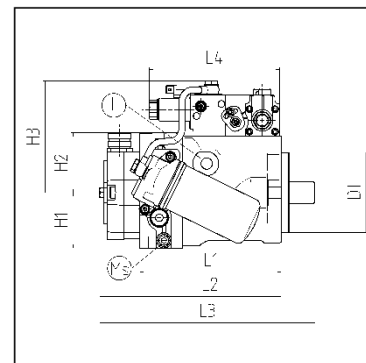
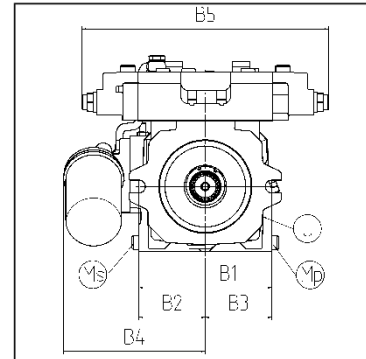

Threads metric in accordance with DIN 3852-1

Suction port at IGP in accordance with ISO 8434-1 L28

High pressure ports similar to ISO 6162-2

Socket cap screw in accordance with ISO 4762

Further threads on request

DIMENSIONS. E-CONTROLS

Control-specific dimensions for HPV-02 with electro-hydraulic controls.

Port sizes and dimensions for E-controls

Rated size	55	75	105	135	165	210	280
D1 [mm]	127		152.4		165.1		
B1 [mm]	181		228.6		224	225	
B2 [mm]	101	116	141	134.5	143	155	
B3 [mm]	101	116	141	134.5	135	139	
B4 [mm]	192	216	219	233	240	246	
B5 [mm] E1				226			
B5 [mm] E2				230			
L1 [mm]	225	242	267	288	319.5	346	392
L2 [mm]	282	304	329	350	485.5	516	571
L3 [mm]	335	359	385	425	560.4	591	646
L4 [mm]				183			
H1 [mm]	88	93	99	106	119.5	134	152
H2 [mm]	95	103	105	112	122.5	133	150
H4 [mm] E1 / E2 AMP-JT connectors	159	164	168	173	189.5	218	231
H4 [mm] E1 DIN connectors	195	200	204	209	225.5	254	(267)
P	SAE 3/4"	SAE 1"		SAE 1 1/4"		SAE 1 1/2"	
S	SAE 3/4"	SAE 1"		SAE 1 1/4"		SAE 1 1/2"	
Mp				M14x1.5			
Ms				M14x1.5			
A gear pump	M27x2			SAE 1"	SAE 3/4"		
B gear pump	M36x2			SAE 1 1/4"	SAE 1 1/4"		
L	M22x1.5		M27x2		M33x2		
U	M22x1.5		M27x2		M33x2		
F	M22x1.5			M27x2			
T				M22x1.5			
X				M14x1.5			
Y				M14x1.5			
Z				M14x1.5			
F2				M14x1.5			

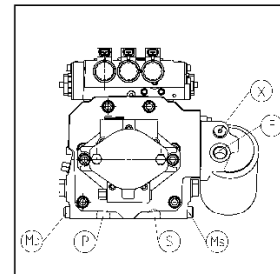
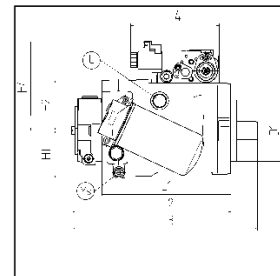
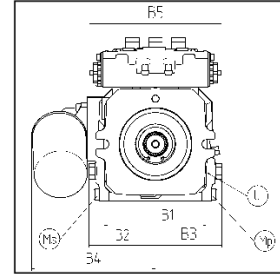

Threads metric in accordance with ISO 6149-1
 Suction port at IGP in accordance with ISO 8434-1 L28
 High pressure ports similar to ISO 6162-2
 Socket cap screw in accordance with ISO 4762
 Further threads on request

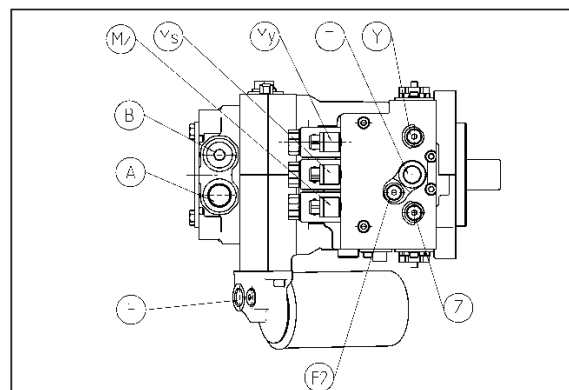

DIMENSIONS. MODULAR SYSTEM

The following diagrams show the proportions of similar components.

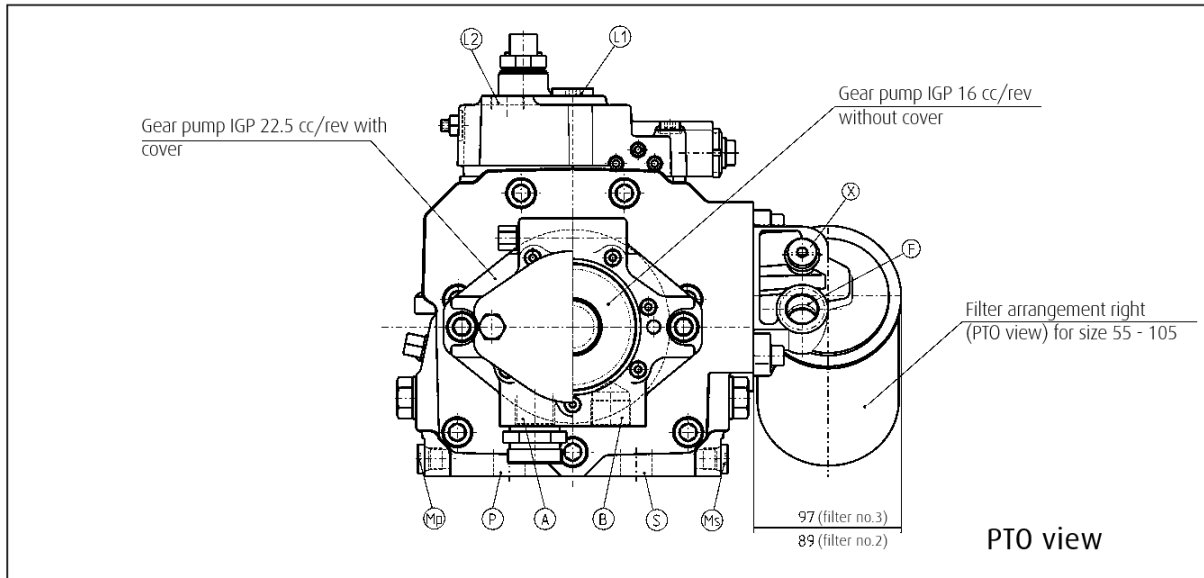

>> M1R-control

>> IGP 16 cc/rev without cover

>> IGP 22.5 cc/rev with cover

>> filter mounting side for rated sizes 55 - 105

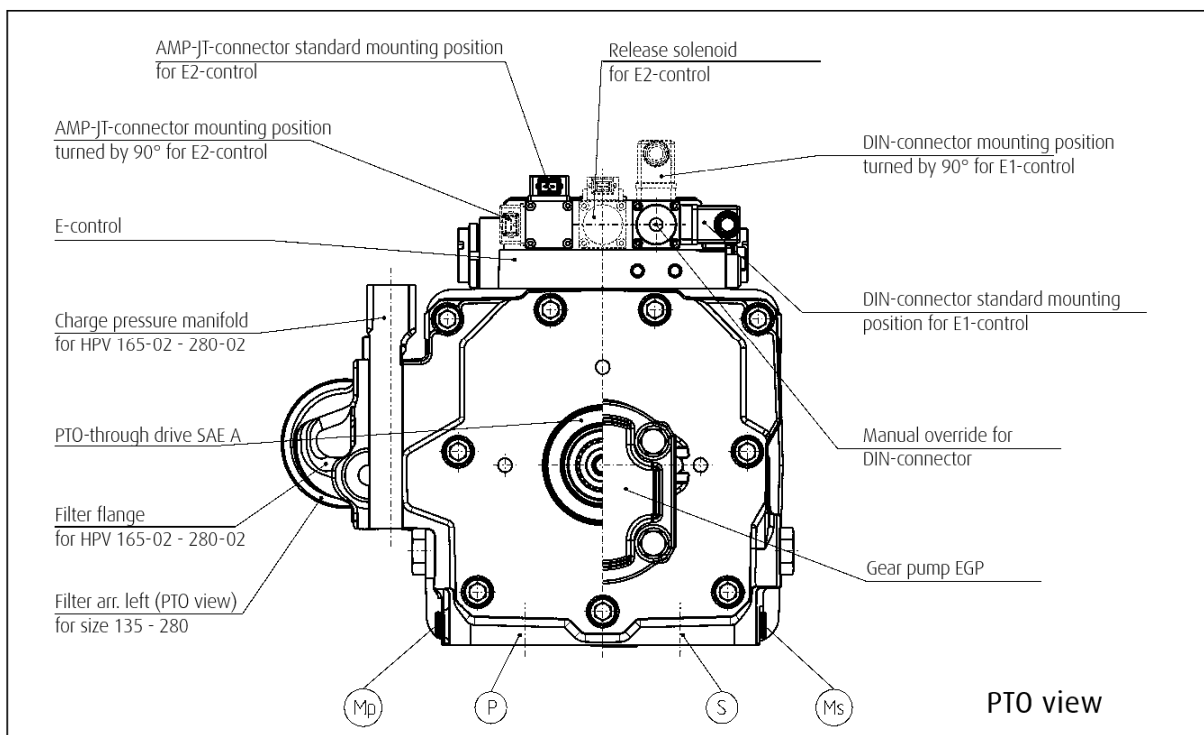

>> E1-control with mounting position of solenoid connectors

>> filter mounting side for rated size 135 - 280

>> E2-control with mounting position of solenoid connectors

>> charge pressure manifold for rated size 210 and 280 without filter

>> manual override

>> SAE A PTO-mounting flange

>> DIN-connector

>> EGP

>> AMP-JT-connector

DIMENSIONS. MODULAR SYSTEM

The following diagrams show the proportions of similar components.

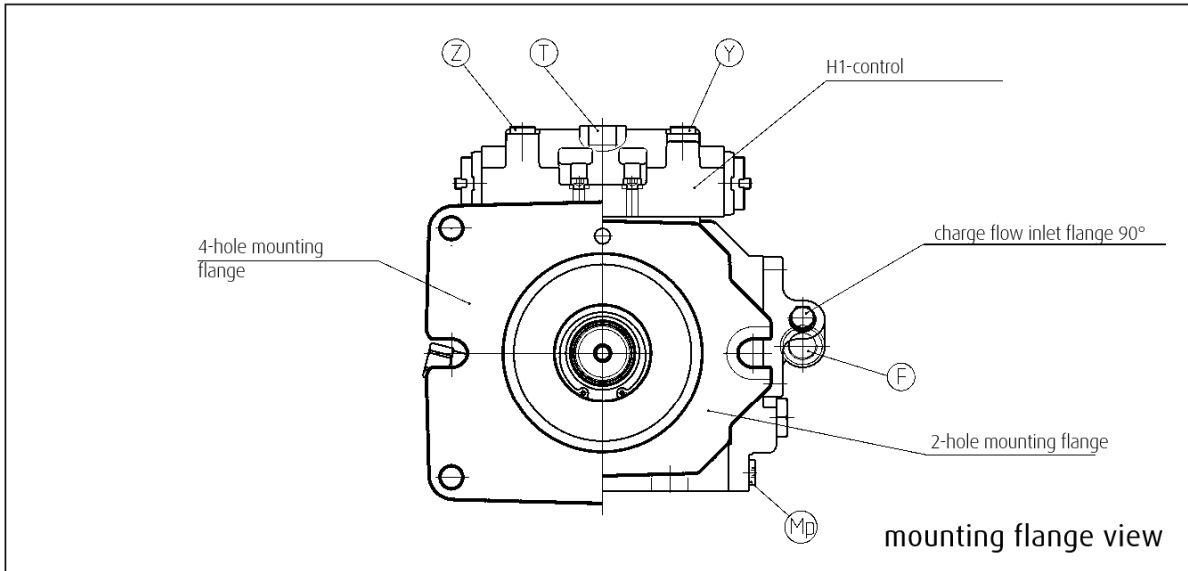

>> 4-hole mounting flange

>> H1-control

>> 2-hole mounting flange

>> filter flange 90° without filter

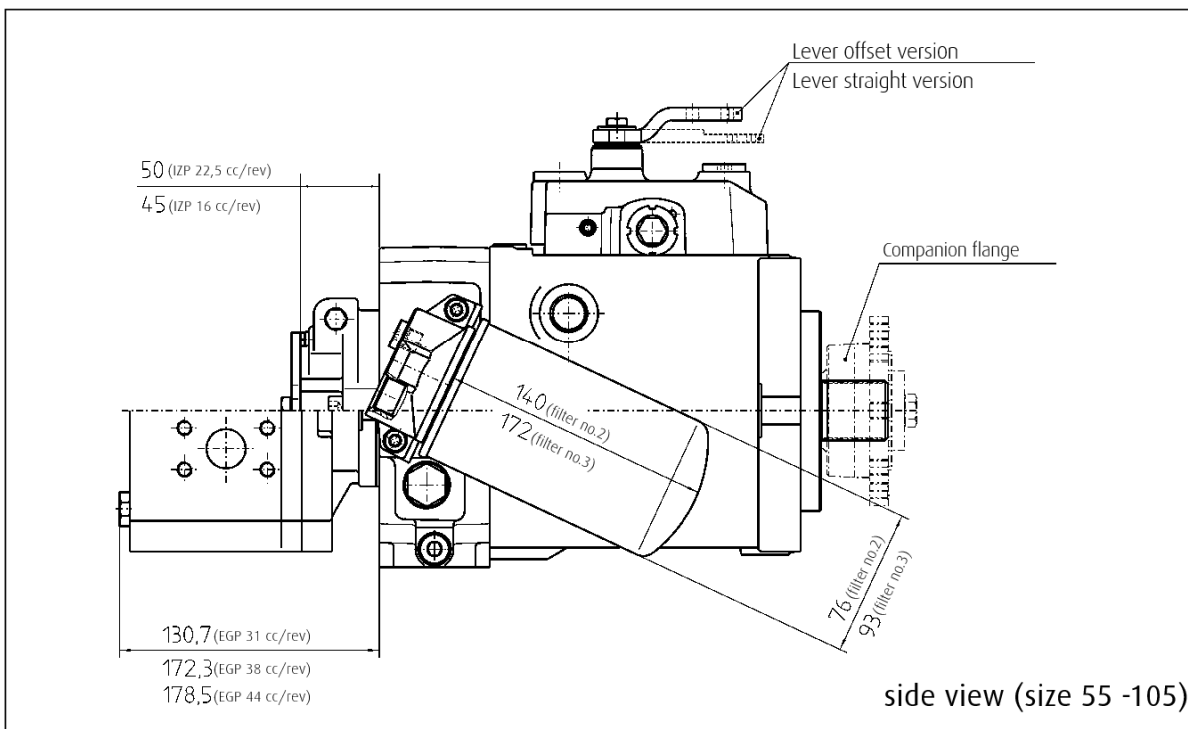

>> M1R-control lever geometry

>> IGP

>> EGP

>> filter

>> companion flange

DIMENSIONS. MODULAR SYSTEM

The following data enable quick calculation of the overall maximum external dimensions. In each case only the relevant dimensions are shown so that length, width and height can simply be determined through addition. The actual fitting dimensions of the respective units are shown on the installation drawing.

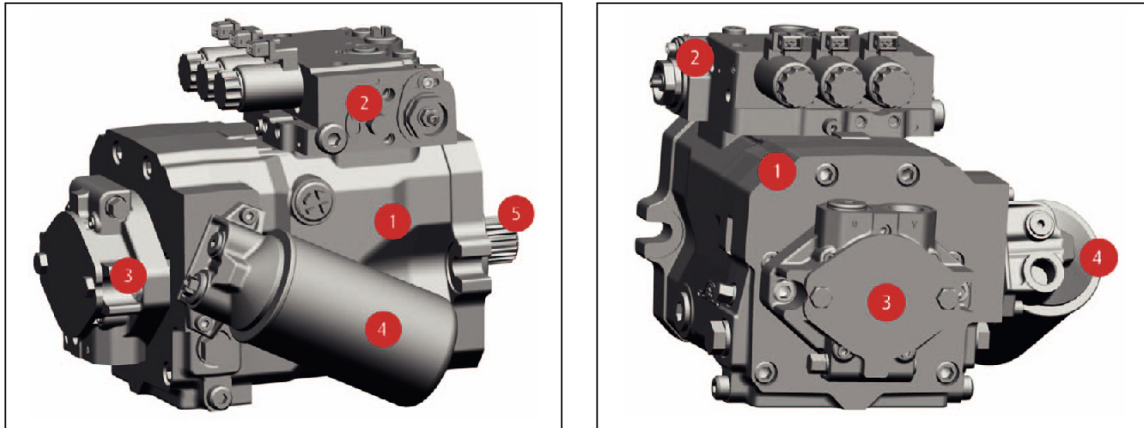

External dimensions for addition

Component	Type	Length	Width	Height
1 Basic unit	55	230	210	185
	75	245	235	190
	105	270	235	210
	135	290	280	220
	165	320	270	245
	210	350	290	275
	280	395	315	305
2 Control	M1R	-	10	95
	H1	-	5	55
	H1P	-	10	75
	CA	-	135	95
	E1/E5	-	5	110
	E1P	-	10	110
	E2	-	15	110
3 Gear pump	16 cc	60	-	-
	22,5 cc	65	-	-
	31 cc	135	-	-
	38 cc	175	-	-
	44 cc	180	-	-
4 Filter	Nr.2	10	95	-
	Nr.3	without gear pump	105	-
	F-port 90°	15	50	-
5 Companion flange not shown		75	-	-
6 Intermediate flange Shown in section <<Dimensions. Tandem pumps>>	55 -> SAE C	47.5		
	75 -> SAE C	47.5		
	105 -> SAE C	37.5		
	135 -> SAE D / C	50 / 31		
	165 -> SAE D / C	61.5 / 26		
	210 -> SAE E / D / C	55 / 68 / 32		
	280 -> SAE E / D / C	39 / 39 / 45.5		

Example:

HPV 135-02 H1 with IGP 22.5, filter no. 3 and companion flange

L. 440 mm

B. 390 mm

H. 275 mm

DIMENSIONS. HPV-02 TANDEM PUMPS

Tandem pumps are created by connecting individual HPV units in series, with the pumps arranged by capacity. Positioning the charge pump(s) at the end of the tandem ensures optimum space utilisation, output allocation and load distribution.

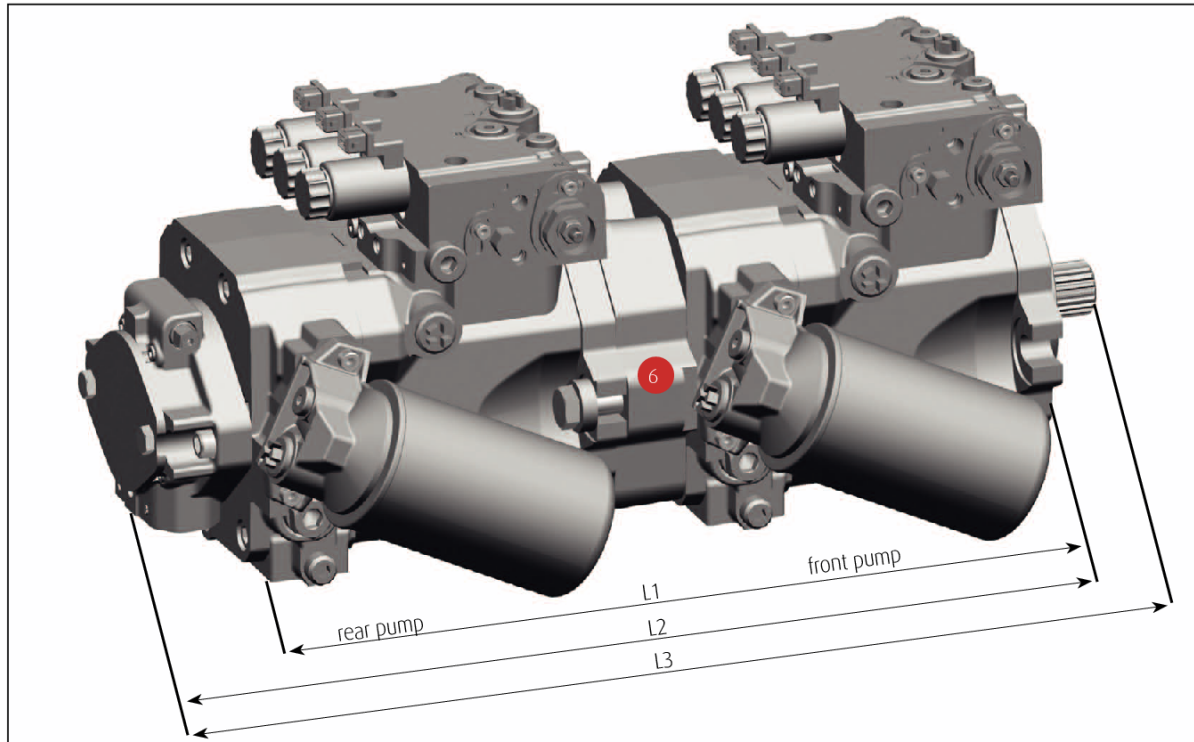

Overall length of tandem pump

Rated size	Rear pump	HPV 55	HPV 75	HPV 105	HPV 135	HPV 165	HPV 210	HPV 280
Front pump	Lengths [mm]							
HPV 55 with IGP 16 cc at rear pump	L1	496	-	-	-	-	-	-
	L2	553	-	-	-	-	-	-
	L3	607	-	-	-	-	-	-
HPV 75 with IGP 22,5 cc at rear pump	L1	513	530	-	-	-	-	-
	L2	575	592	-	-	-	-	-
	L3	631	648	-	-	-	-	-
HPV 105 with IGP 22.5 cc at rear pump	L1	529	546	572	-	-	-	-
	L2	591	608	634	-	-	-	-
	L3	647	663	586	-	-	-	-
HPV 135 with IGP 22.5 cc at rear pump	L1	543	560	586	640	-	-	-
	L2	605	622	648	702	-	-	-
	L3	680	696	722	777	-	-	-
HPV 165 with EGP 38 cc at rear pump	L1	571	588	613	670	684	-	-
	L2	746	763	788	844	859	-	-
	L3	820	837	865	919	934	-	-
HPV 210 with EGP 38 cc at rear pump	L1	610	627	653	702	722	731	-
	L2	782	799	825	874	897	903	-
	L3	857	874	900	947	971	978	-
HPV 280 with EGP 44 cc at rear pump	L1	655	672	698	723	755	777	823
	L2	834	851	877	903	935	956	1002
	L3	909	925	951	978	1009	1030	1076

DIMENSIONS. HPV-HPR-02 MULTIPLE PUMPS

Multiple pumps are created by combining individual pump units in series, with the pumps arranged by capacity. Positioning the gear pump(s) at the end of the unit ensures optimum space utilization, output allocation and load distribution. The following table is based on the gear pump acting as charge pump for the HPV-02 variable pump.

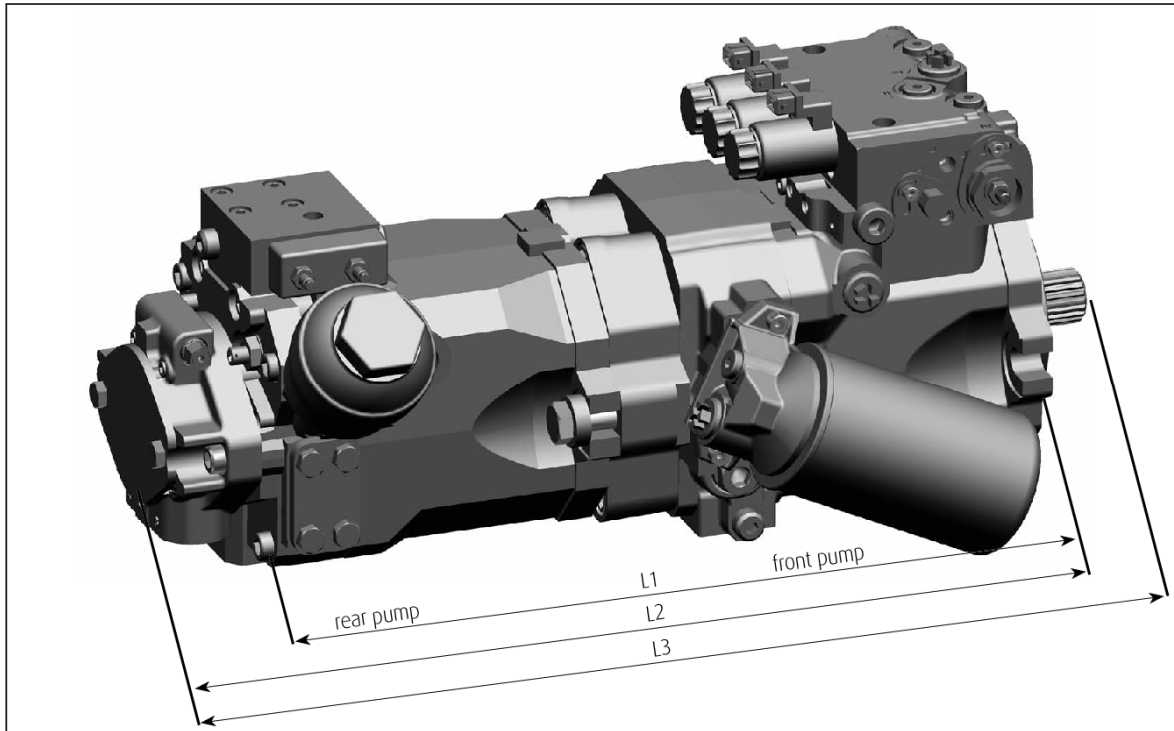

Overall length of multiple pump

Rated size	Rear pump	HPR 55	HPR 75	HPR 105	HPR 135	HPR 165	HPR 210	HPR 280
Front pump	Lengths [mm]							
HPV 55 with IGP 16 cc at HPR	L1	492	-	-	-	-	-	-
	L2	549	-	-	-	-	-	-
	L3	603	-	-	-	-	-	-
HPV 75 with IGP 22.5 cc at HPR	L1	509	521	-	-	-	-	-
	L2	586	598	-	-	-	-	-
	L3	642	653	-	-	-	-	-
HPV 105 with IGP 22.5 cc at HPR	L1	525	536	567	-	-	-	-
	L2	602	613	629	-	-	-	-
	L3	657	669	684	-	-	-	-
HPV 135 with IGP 22.5 cc at HPR	L1	539	550	581	637	-	-	-
	L2	616	627	643	699	-	-	-
	L3	690	702	717	774	-	-	-
HPV 165 with EGP 38.5 cc at HPR	L1	565	578	608	667	715	-	-
	L2	741	753	783	842	882	-	-
	L3	815	827	857	916	956	-	-
HPV 210 with EGP 38.5 cc at HPR	L1	606	618	648	699	722	733	-
	L2	793	805	820	871	897	905	-
	L3	868	879	895	945	972	980	-
HPV 280 with EGP 44 cc at HPR	L1	651	663	693	720	768	779	834
	L2	845	856	872	900	948	958	1014
	L3	919	931	946	975	1023	1033	1089

