

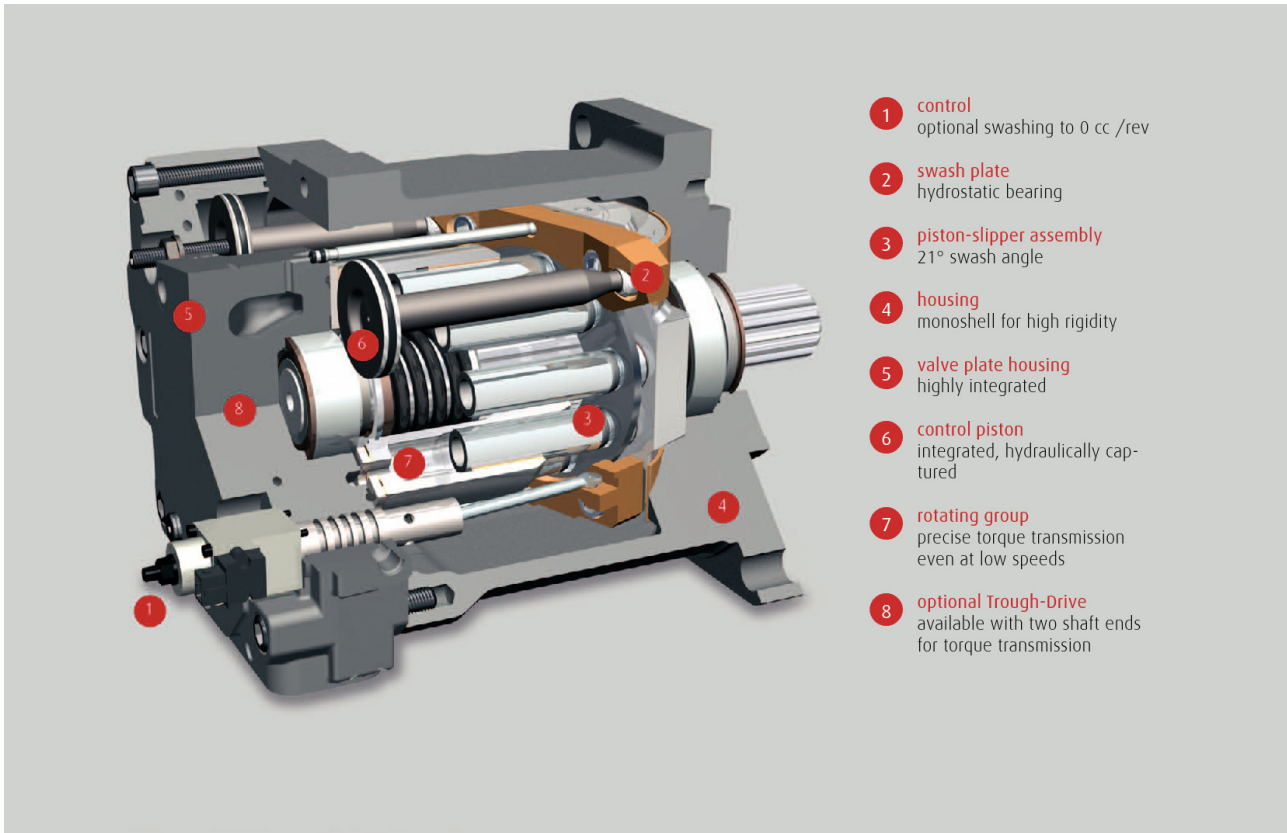

MOTOR HEAVY DUTY



HMV/R-02 PTO. BREAKTHROUGH IN DRIVE SYSTEMS DESIGN.



Design characteristics

- >> high pressure axial piston motor in swash plate design for closed and open loop systems
- >> optimised start-up and low-speed characteristics
- >> optionally with purge valves for circuit and case flushing
- >> HP valves possible
- >> through-shaft with bare shaft end or coupling flange
- >> SAE High pressure ports, radial or axial
- >> SAE mounting flange with ANSI or SAE spline shaft
- >> plug-in version optional
- >> speed sensor optional

Product advantages

- >> smooth low-speed operation
- >> high starting torque
- >> lower emissions through speed reduction
- >> compact design
- >> high power density
- >> high reliability
- >> long service life
- >> highly dynamic response characteristics
- >> simplified drive line

LinDrive = Precision x Dynamics x Reliability = Benefit^o



LINDE HYDRAULICS PRODUCT RANGE

Find the right products for your application.

Product range

Product		Application	Linde product name
Pump	Self-regulating pump	open loop operation	HPR-02
	Variable pump	closed loop operation	HPV-02
Motor	Variable motor	closed and open loop operation	HMV-02
	Regulating motor	closed and open loop operation	HMR-02
	Fixed motor	closed and open loop operation	HMF-02
		open loop operation	HMF-02 P
		closed and open loop operation	HMA-02
Valve Technology	LSC manifold plate	open loop operation	VT modular
	Monoblock	open loop operation	Monoblock
Electronics	Electronic control unit	closed and open loop operation	LINC
	Peripheral equipment	closed and open loop operation	
	Software	diagnosis and configuration	LinDiag®

CONTENT HMF / A / V / R-02

General technical data	4	Motor types	22
Transmission concept	6	>> HMV-02	24
Operating parameters		>> HMV D-02 double motor	28
>> Life time recommendations	7	>> HMV T-02 tandem motor	29
>> Filtering	7	>> Motor equipment. COR-block	30
>> Pressure fluids	8	>> HMR-02	31
Torque transfer	9	>> HMF-02	34
>> Mounting flange	10	>> HMF-02 P	36
>> Output shaft	12	>> HMA-02	37
>> PTO	13	Dimensions	
The closed loop	14	>> HMV-02	38
The open loop	15	>> HMR-02	40
Functions		>> HMF-02	42
>> Purge and case flushing	16	>> Connections	43
>> Servo pressure supply	17	Modular system features	43
>> Crossline (secondary) protection	18	Contact	44
>> Signal selection for pressure regulator	19		
>> Counterbalance valve	20		
>> Speed sensor	21		

The data on which this brochure is based correspond to the current state of development. We reserve the right to make changes in case of technical progress. The dimensions and technical data of the individual installation drawings are prevailing. The features listed in this data sheet are not available in all combinations and nominal sizes. Our sales engineers will be happy to provide advice regarding the configuration of your hydraulic system and on product selection.



GENERAL TECHNICAL DATA.

Overview of technical data

Rated size			28	35	50/55	75	105
Displacement HMV-02 can be set to 0 cc/rev displacement	Maximum V_{max} HMV 55-02, HMR 55-02: 54,8 HMF 50-02: 51,3	cc/rev	28.6	35.6	51.3/54.7	75.9	105.0
	Minimum V_{min} only for variable and regulating motors	cc/rev	-	-	18.3	25.3	35.0
Speed	Max. continuous speed (100% duty cycle) at maximum displacement	rpm	4500	4500	4100	3800	3500
	Max. speed (intermittent) at maximum displacement, higher speed on request	rpm	4800	4800	4400	4100	3800
	Max. continuous speed (100% duty cycle) at min. displacement	rpm	-	-	4700	4400	4100
	Max. speed (intermittent) at minimum displacement, higher speed on request	rpm	-	-	5300	5000	4700
Pressure	Nominal pressure other values on request	bar	420				
	Peak pressure	bar	500				
	Continuous pressure (Δp)	bar	250				
	Permissible housing pressure (absolute)	bar	2.5				
Torque (theoretical)	Continuous output torque at continuous pressure	Nm	114	142	204/218	302	418
	Max. output torque at maximum operating pressure	Nm	191	238	343/366	507	702
Power (theoretical)	Continuous power at maximum continuous speed, maximum displacement and continuous pressure	kW	54	67	88/93	120	153
	Maximum Power at max. continuous speed, max. displacement and max. operating pressure	kW	90	108	147/157	202	257
Permissible shaft loads	Axial input /output force	N	2000				
	Radial	N	on request				
Perm. housing temp.	Perm. housing temperature with minimum perm. viscosity > 10 cSt	°C	90				
Weights	Fixed displacement motor with 2-hole mounting flange	kg	16	16	19	26	33
	Variable and regulating motor with 2- or 4-hole mounting flange	kg	-	-	28	32	42
	Max. moment of inertia	kgm ² x 10 ⁻²	0.25	0.25	0.49	0.79	1.44

Standard Linde-name plate

Each Linde Hydraulics unit features a name plate showing the type and the serial number. For a single order via 'open variant' a customer-specific number or free text with up to 15 characters can be stamped on the name plate.

Type	HMV 105-02	Series 02 variable motor with the rated size of 105
	2581	the last 4 figures of the Bill of Material
Serial-No.	H2X	2340002581
	234	Type number of HMV 105-02
	T	Letter indicating year of production
	12345	Serial number
Part No.	12345678	Free text field for up to 15 characters



GENERAL TECHNICAL DATA.

Overview of technical data

Rated size			135	165	210	280	135D	
Displacement HMV-02 can be set to 0 cc/rev displacement	Maximum V_{max}	cc/rev	135.6	165.6	210	281.9	271.2	
	Minimum V_{min} only for variable and regulating motors	cc/rev	45.2	55.2	70	93	67	
Speed	Max. continuous speed (100 % duty cycle) at maximum displacement	rpm	3200	3100	2700	2400	3200	
	Max. speed (intermittent) at maximum displacement, higher speed on request	rpm	3500	3400	3000	2700	3500	
	Max. continuous speed (100 % duty cycle) at minimum displacement	rpm	3700	3500	3200	2900	3700	
	Max. speed (intermittent) at minimum displacement, higher speed on request	rpm	4000	3900	3500	3200	4000	
Pressure	Nominal pressure other values in request	bar	420					
	Peak pressure	bar	500					
	Continuous pressure (Δp)	bar	250					
	Permissible housing pressure (absolute)	bar	2.5					
Torque (theoretical)	Continuous output torque at continuous pressure	Nm	540	659	836	1122	1079	
	Max. output torque at maximum operating pressure	Nm	906	1107	1404	1884	1748	
Power (theoretical)	Continuous power at maximum continuous speed, maximum displacement and continuous pressure	kW	181	214	236	282	362	
	Maximum power at max. continuous speed, max. displacement and max. operating pressure	kW	304	359	397	474	586	
Permissible shaft loads	Axial input / output force	N	2000					
	Radial	N	on request					
Perm. housing temperature	Perm. housing temperature with minimum perm. viscosity > 10 cst	°C	90					
Weights	Fixed displacement motor with 2-hole mounting flange	kg	39	75	100	-	-	
	Variable and regulating motor with 2- or 4-hole mounting flange	kg	56	76	101	146	149	
	Max. moment of inertia	kgm ² x 10 ⁻²	2.15	3.06	4.68	9.36	2.15	

TRANSMISSION CONCEPT.

Equipment manufacturers profit by the Linde Hydraulics transmission concept. Due to the direct conversion of the prime mover speed into wheel speed it is possible to reduce the number of drive line components and the energy losses in the operating cycle.

Speed steps of transmission concepts

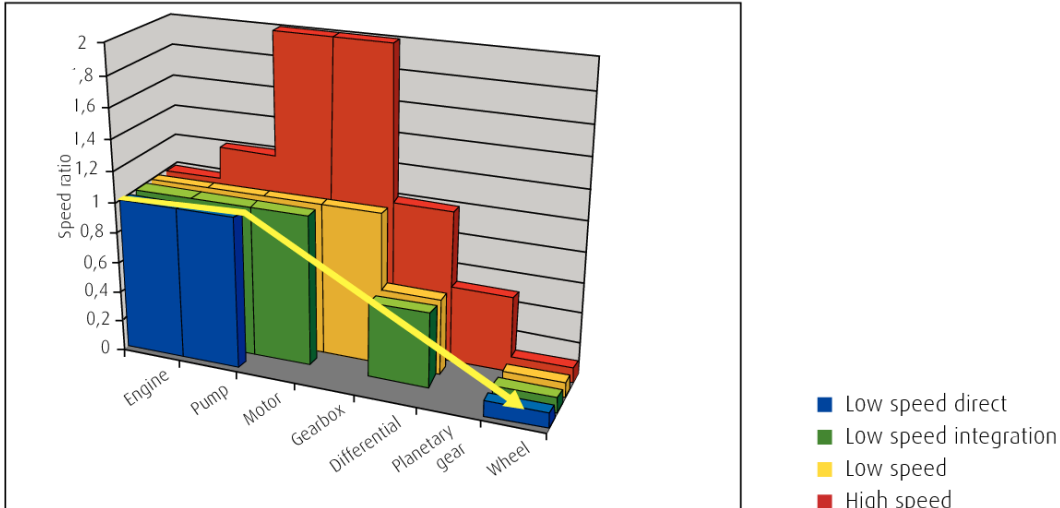

Starting torque

Linde hydraulic motors offer uniformly high torque for smooth start up. Right from the start.

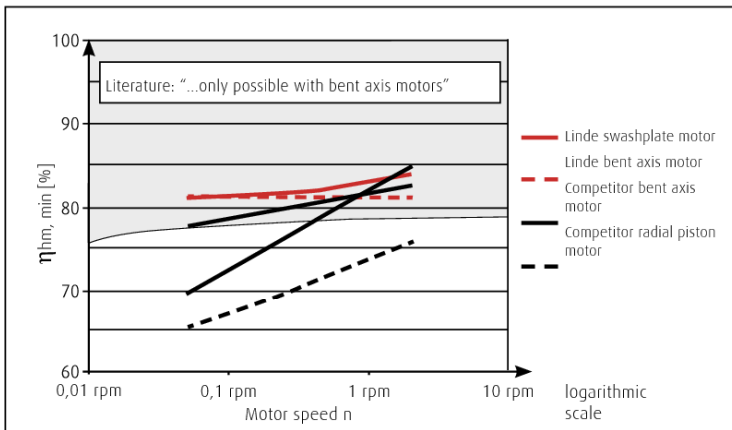

Torque at 350 bar and 2 rpm

of a bent axis motor

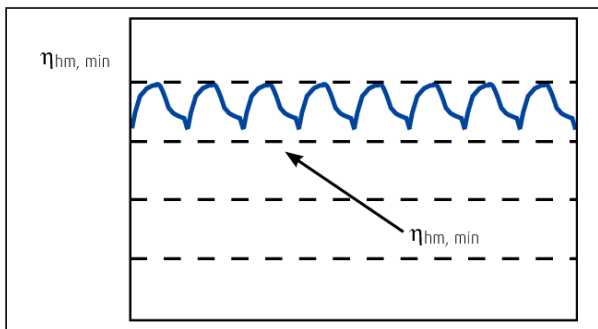

of a swashplate motor

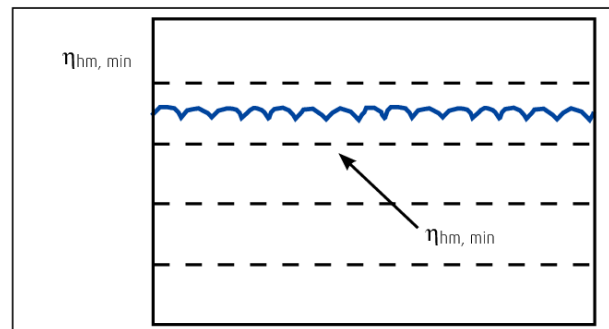

OPERATIONAL PARAMETERS. LIFE TIME RECOMMENDATIONS

Linde high pressure units are designed for excellent reliability and long service life. The actual service life of a hydraulic unit is determined by numerous factors. It can be extended significantly through proper maintenance of the hydraulic system and by using high-quality hydraulic fluid.

Beneficial conditions for long service life

- >> Speed lower continuous maximum speed
- >> Operating pressure less than 300 bar Δp on average
- >> Max. pressure only at reduced displacement
- >> Viscosity 15 ... 30 cSt
- >> Power continuous power or lower
- >> Purity of fluid 18/16/13 in accordance with ISO 4406 or better

Adverse factors affecting service life

- >> Speed between continuous maximum speed and intermittent maximum speed
- >> Operating pressure more than 300 bar Δp on average
- >> Viscosity less than 10 cSt
- >> Power continuous operation close to maximum power
- >> Purity of fluid lower than 18/ 16/ 13 in accordance with ISO 4406

Operational parameters. Filtration

In order to guarantee long-term proper function and high efficiency of the hydraulic motors the purity of the pressure fluid must comply with the following criteria according to Linde Works Standard WN 51 210. High purity oil can extend the service time of the hydraulic system significantly.

- >> For reliable proper function and long service life 18/16/13 in accordance with ISO 4406 or better
- >> Minimum requirements 20/18/15 in accordance with ISO 4406
- >> Commissioning The minimum purity requirement for the hydraulic oil is based on the most sensitive system component. For commissioning we recommend a filtration in order to achieve the required purity.
- >> Filling and operation of hydraulic systems The required purity of the hydraulic oil must be ensured during filling or topping up. When drums, canisters or large-capacity tanks are used the oil generally has to be filtered. We recommend the implementation of suitable measures (e.g. filters) to ensure that the required minimum purity of the oil is also achieved during operation
- >> International standard

Code number according to ISO 4406	purity class according to SAE AS 4059E
18/16/13	corresponds to 8A/7B/7C
20/18/15	9A/8B/8C

OPERATIONAL PARAMETERS. PRESSURE FLUIDS

In order to ensure the functional performance and high efficiency of the hydraulic motors the viscosity and purity of the operating fluid should meet the different operational requirements. Linde recommends using only hydraulic fluids which are confirmed by the manufacturer as suitable for use in high pressure hydraulic installations or approved by the original equipment manufacturer.

Permitted pressure fluids

- >> Mineral oil HLP to DIN 51 524-2
- >> Biodegradable fluids in accordance with ISO 15 380 on request
- >> Other pressure fluids on request

Linde offers an oil testing service in accordance with VDMA 24 570 and the test apparatus required for in-house testing. Prices available on request.

Recommended viscosity ranges

Pressure fluid temperature range	[°C]	-20 to +90
Working viscosity range	[mm ² /s] = [cSt]	10 to 80
Optimum working viscosity	[mm ² /s] = [cSt]	15 to 30
Max. viscosity (short time start up)	[mm ² /s] = [cSt]	1000

In order to be able to select the right hydraulic fluid it is necessary to know the working temperature in the hydraulic circuit. The hydraulic fluid should be selected such that its optimum viscosity is within the working temperature range (see tables).

The temperature should not exceed 90 °C in any part of the system. Due to pressure and speed influences the leakage fluid temperature is always higher than the circuit temperature. Please contact Linde if the stated conditions cannot be met in special circumstances.

Viscosity recommendations

Working temperature [°C]	Viscosity class [mm ² /s] = [cSt] at 40 °C
approx. 30 to 40	22
approx. 40 to 60	32
approx. 60 to 80	46 or 68

Further information regarding installation can be found in the operating instructions.

TORQUE TRANSMISSION.

Depending on the selected components, different torques may be transferred. Please ensure that the load transfer components such as mounting flange and PTO through-shaft are designed adequately. Our sales engineers will be pleased to provide design advice.

Torque transmission of the hydraulic motor

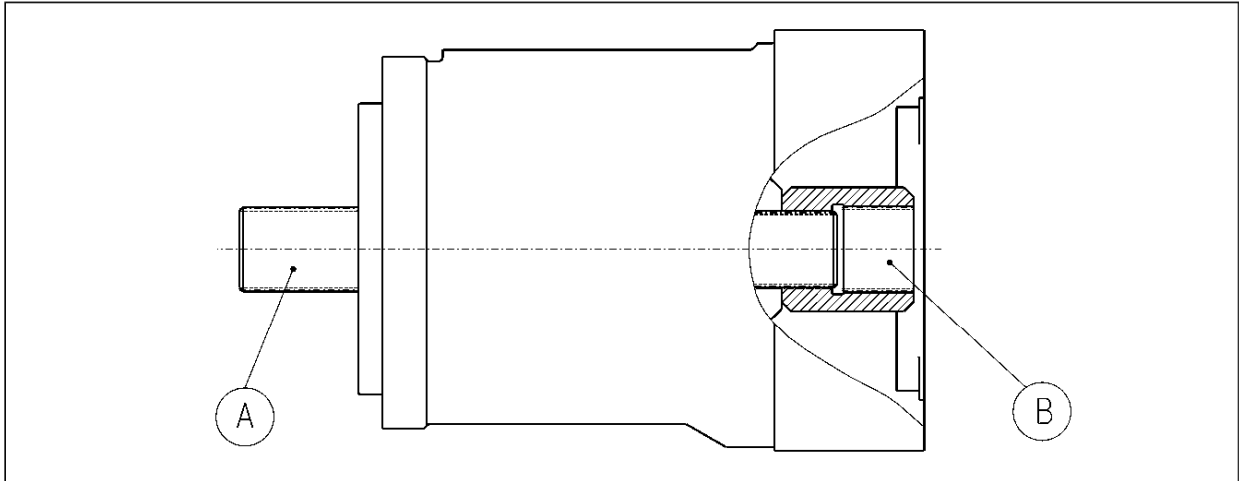

The diagram Torque transmission of HMF / A / V / R-02 shows the output side A and the PTO through-shaft B of a motor. The information on the following pages refers to

- >> mounting flange and drive shaft A
- >> PTO flange and through shaft B

A) Flange profile

Bolt hole dimensions		Rated size HMF / A / V / R-02							
		50/55	75	105	135	165	210	280	135 D
M1 inside diameter	mm	17.5	17.5	17.5	21.5	21.5	22	22	21.5
M2 outside diameter	mm	40	34	34	40	40	-	-	40
M3 length	mm	20	20	20	20	25	30	30	20

Bolt hole diameter

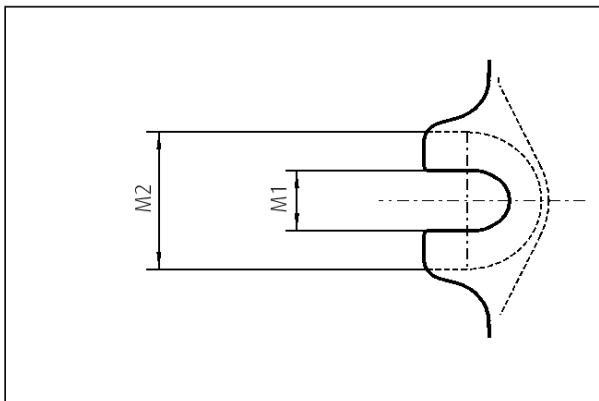

Bolt hole length

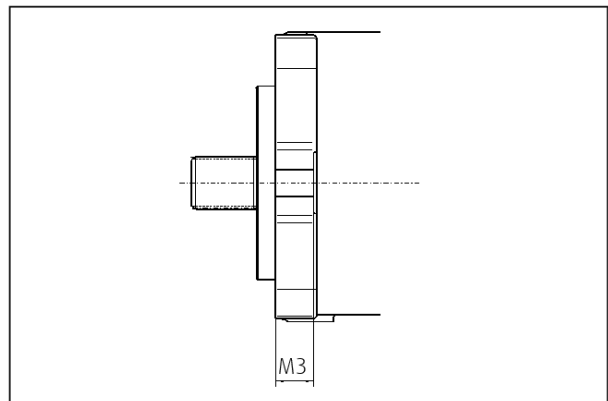

TORQUE TRANSMISSION. MOUNTING FLANGE

Mounting suggestions

Mounting flange dimensions in accordance with SAE J744	For rated size	Mounting				Dimensions		
		Washer	Screw	Torque (8.8) [Nm]	Torque (10.9)* [Nm]	K [mm]	H [mm]	V [mm]
SAE B, B-B	28 & 35	12.5x25x4	M12	80	110	146.0	-	-
SAE C, C-C 2-holes	55-105	17x33x10	M16	195	275	181.0	-	-
SAE D 2-holes	135 & 165	21x37x8	M20	385	540	228.6	-	-
SAE D 2-holes with 4 additional bolt holes	135 D	-	M16	-	275	228.6	230	190
SAE E 4-holes	210 & 280	-	M20	385	540	224.5	-	-

*) Option for standard design, necessary for tandem units

2-hole flange

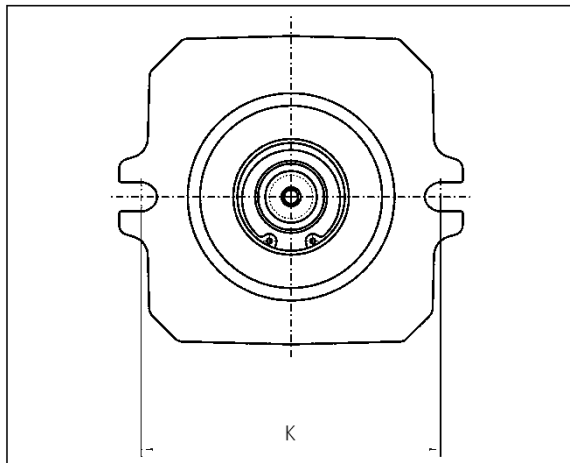

4-hole flange

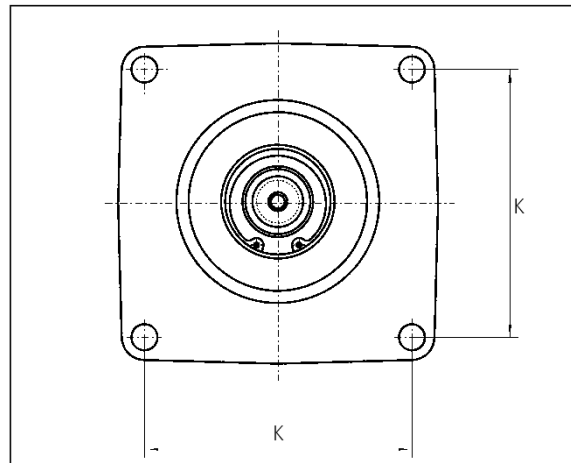

2-hole flange with 4 additional bolt holes

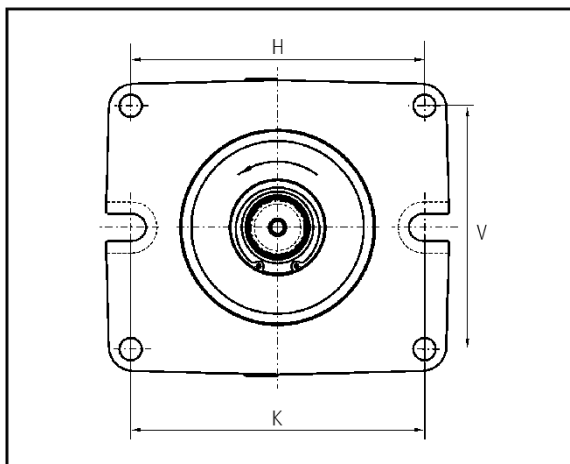

TORQUE TRANSMISSION. MOUNTING FLANGE

Plug-in housing for HMF/V/R 75-02

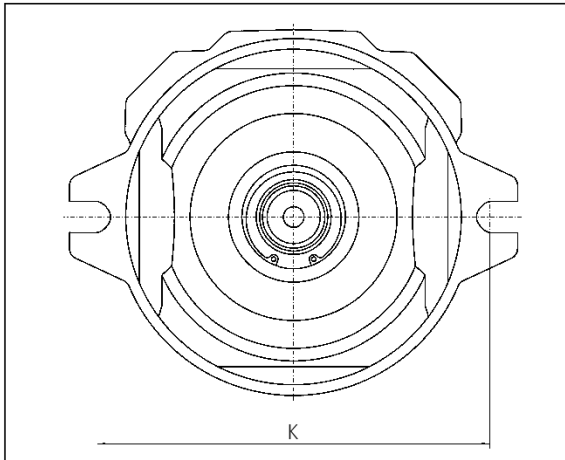

Rated size	75	
D1 [mm]	190	
D2 [mm]	251	
K [mm]	224	
L1 [mm]	143	
L2 [mm]	124	

Plug-in housing for HMF/V/R 105-02 und 135-02

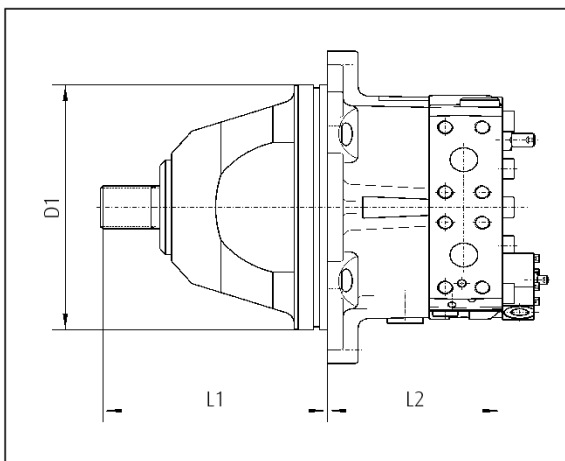
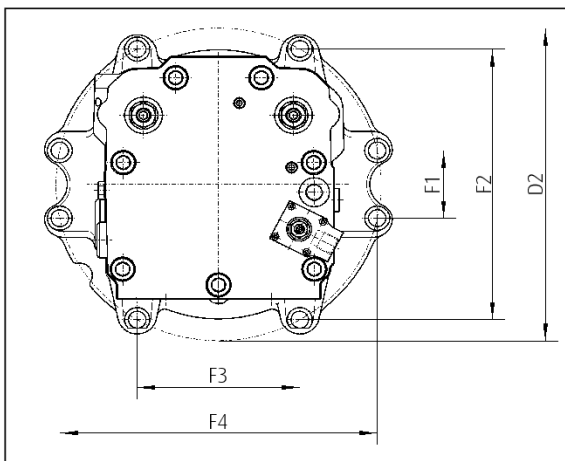

Rated size	105	135
D1 [mm]	216	
D2 [mm]	282	
F1 [mm]	55.8	
F2 [mm]	223.4	
F3 [mm]	129	
F4 [mm]	251.8	
L1 [mm]	169	
L2 [mm]	132	175

TORQUE TRANSMISSION. DRIVE SHAFT

A) Dimensions drive shafts

Shaft Spline (in accordance with ANSI B92.1)	SAE J744 code for centering and shaft	Outside diameter [mm]	Usable spline length [mm]	Shaft type	Available for rated size									
					28/35	50/55	75	105	135	165	210	280	135 D	
16/32, 15 t	B-B	24.98	29	1	x									
12/24, 14 t	C	31.22	30	2			x							
16/32, 21 t		34.51	39.5	1		x	x							
16/32, 23 t		37.68	38.5	1				x						
8/16, 13 t	D	43.71	50	2					x	x				
16/32, 27 t		44.05	62	1					x	x				x
8/16, 15 t	F	50.06	58	1							x*	x		
16/32, 33 t		53.57	58	1								x*		

*) Recommended shaft for tandem configurations

A) Linde Hydraulics shaft types

Type 1. Without undercut

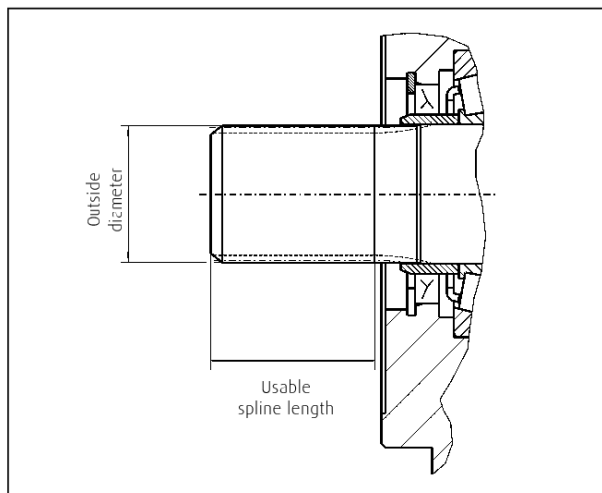

Type 2. With undercut

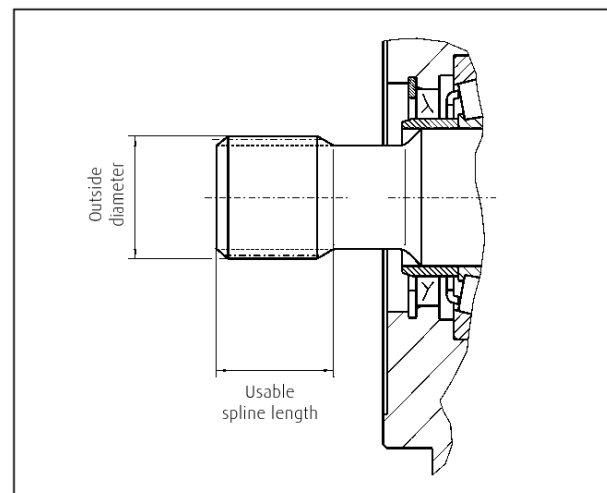

A) Shaft torque

Shaft		16/32 15 t	16/32 21 t	16/32 21 t	16/32 23 t	16/32 27 t	16/32 27 t	8/16 15 t	16/32 33 t
Cont. torque	Nm	283	435	604	836	1079	1318	1671	2243
Max. torque	Nm	422	649	900	1245	1608	1964	2490	3343

TORQUE TRANSMISSION. PTO THROUGH-DRIVE MOTOR

Based on a standard Series 02 variable hydraulic motor with single shaft end, the PTO Through-Drive Motor features two shaft ends for torque transfer. This enables the hydraulic motor to be installed directly in the drive line without transfer gearbox, reducing noise emission and fuel consumption. At the same time the overall efficiency increases.

B) PTO dimensions for HMV-02

Rated size		105	135	165	210	280
Z drive shaft profile in accordance with ANSI B92.1		16/32, 19 t	16/32, 21 t	16/32, 22 t	16/32, 24 t	16/32, 27 t
D shaft diameter	mm	31.2	34.51	36.05	39.27	44.05
L1 shaft end length-housing	mm	30.1	16.2	-0.5	20.9	18
L2 usable spline length	mm	41.5	31	31	44	47
L3 bearing stop	mm	49.6	32	32.8	57.2	62
Continuous torque	Nm	418	540	659	836	1122
Max. torque	Nm	736	1068	1305	1654	2221

B) PTO dimensions

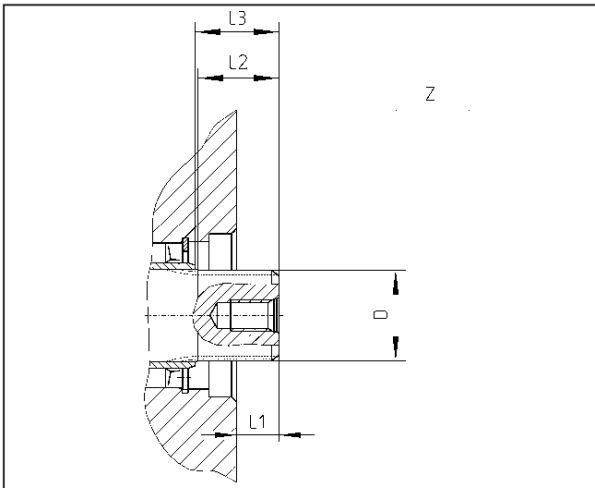

PTO Through-Drive motor w. coupling flanges

For a direct installation into the drive line

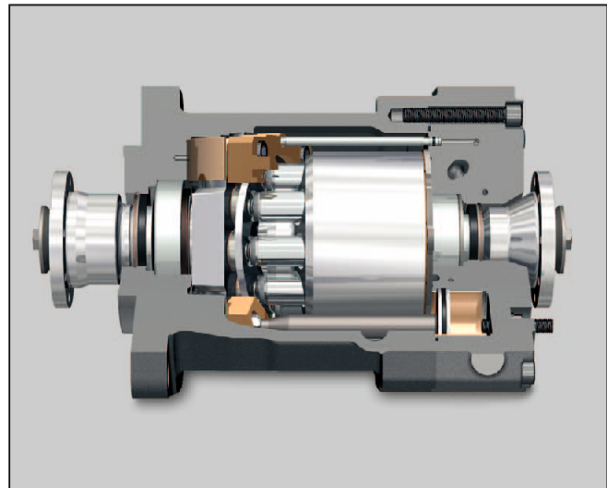

THE CLOSED LOOP.

Representation of the hydraulic components of a closed loop hydrostatic drive: Variable electro-hydraulic controlled HPV-02 E1 pump (top view) and fixed displacement motor HMF-02 plus filter, cooler and oil tank. The function diagram and the circuit diagram show two types of cooling.

Function diagram

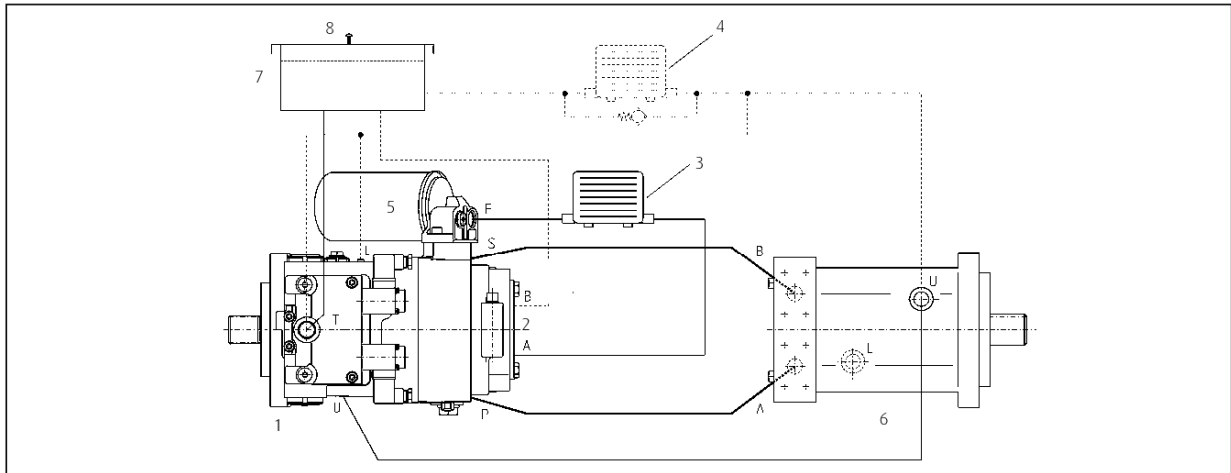

Circuit diagram

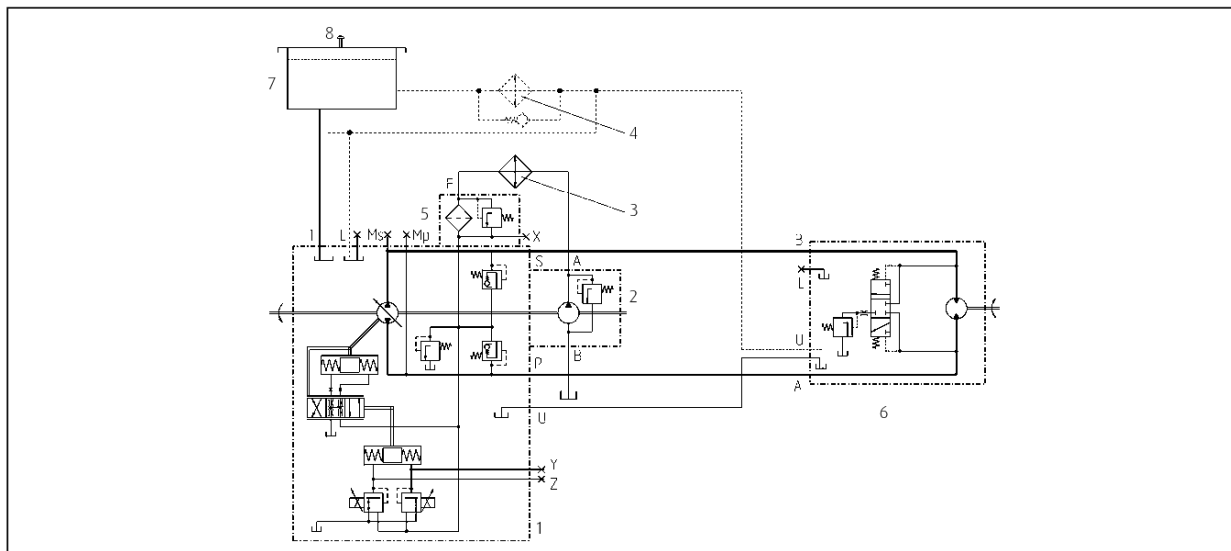

- | | |
|---------------------------------------|--------------------------|
| 1 Hydraulic pump HPV-02 R E1 | 5 Filter |
| 2 Charge pump | 6 Hydraulic motor HMF-02 |
| 3 Option 1: Cooler in charge circuit | 7 Tank |
| 4 Option 2: Cooler in the return line | 8 Venting valve |

THE OPEN LOOP.

Representation of hydraulic components in an open loop circuit, based on the LSC system as an example: A HPR-02 regulating pump with load sensing function for energy-saving flow on demand control and VW load sensing directional control valves for load-independent and simultaneous movements of several consumers without mutual influencing. The system is complemented with proven Linde products such as electronic controllers, swing drive and hydraulic motors.

Function diagram

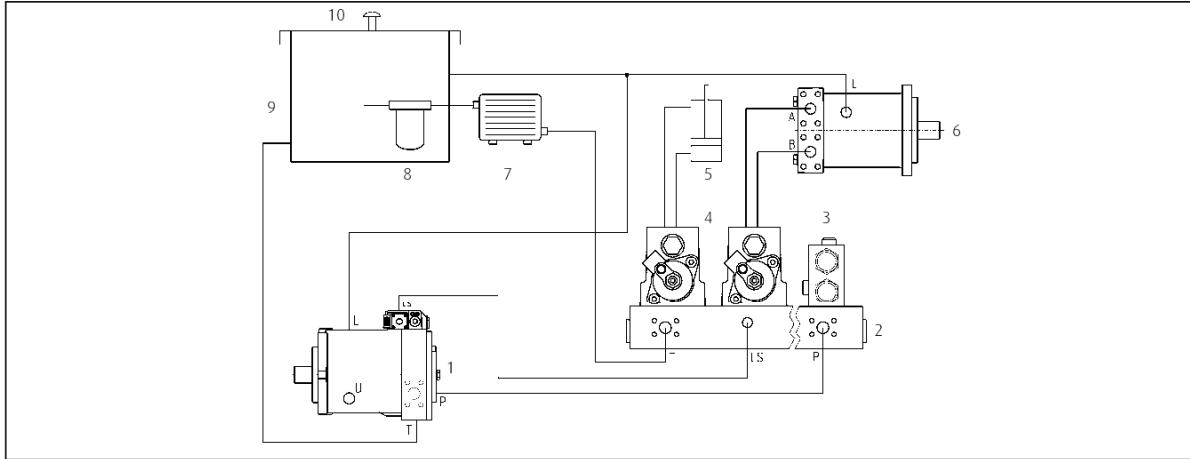

Circuit diagram

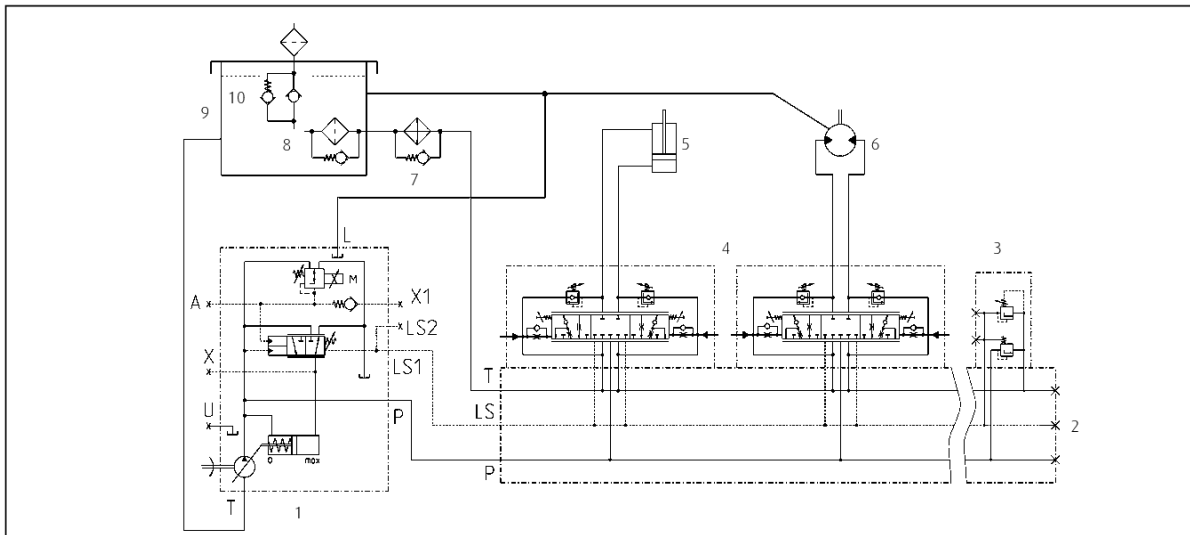

- | | |
|------------------------------|--------------------------|
| 1 Hydraulic pump HPR-02 E1L | 6 Hydraulic motor HMF-02 |
| 2 Manifold valve plate | 7 Cooler |
| 3 Pressure relief function | 8 Filter |
| 4 Directional control valves | 9 Tank |
| 5 Hydraulic cylinder | 10 Venting valve |

Further information about the LSC system is available in the data sheets "HPR-02" and "VT modular" or directly from our sales engineers.

FUNCTIONS. PURGE AND CASE FLUSHING

Purge and case flushing is used

- >> for reducing the temperature of the motor and the system in the open and closed loop circuits
- >> for replacing the oil in the circuit
- >> to enhance filtration and
- >> for removing air from the system

For equipment options for Series 02 motors please refer to the model code.

Purge flow in closed loop circuit

Version	Purge valve pressure CBV setting	Diagram	Purge Flow	Diameter of orifice
Standard	10 bar with 20 bar feed pressure	3	10 l/min	2.5 mm
Standard	14 bar with 20 bar feed pressure	2	10 l/min	without orifice
Restricted	10 bar with 20 bar feed pressure	3	5 l/min	2 mm
Restricted	14 bar with 20 bar feed pressure	3	5 l/min	2.5 mm
Increased	10 bar with 20 bar feed pressure	2	20 l/min	without orifice
Flow controlled	14 bar with >20 bar feed pressure	4	4 l/min	with flow regulator

Purge valve 1. Without (0 l/min)

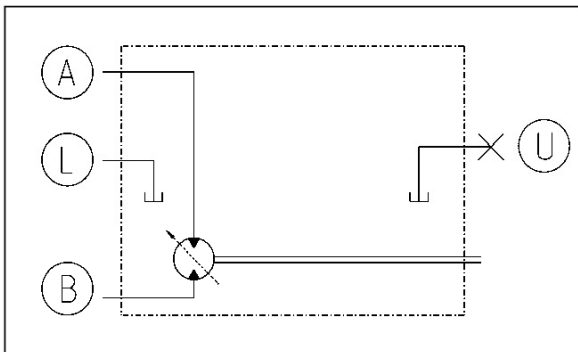

Purge valve 2. Standard and increased

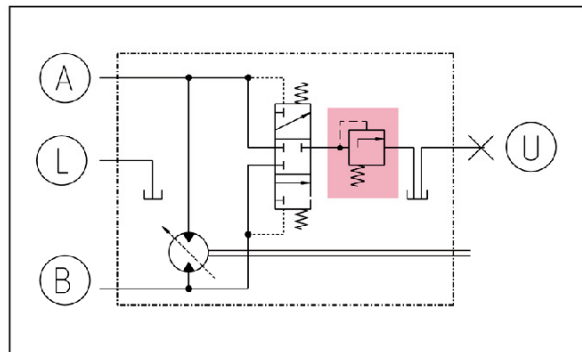

Purge valve 3. Restricted

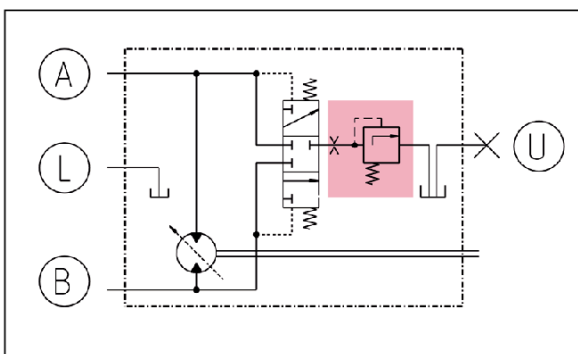

Purge valve 4. Flow controlled

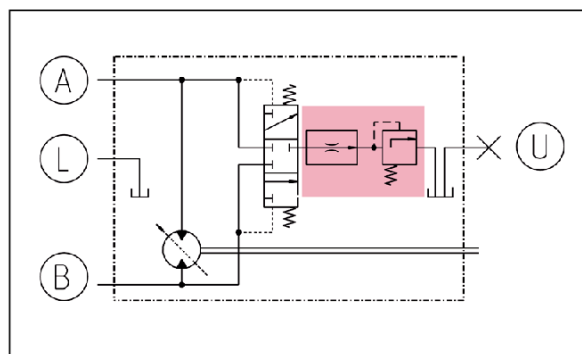

FUNCTIONS. SERVO SUPPLY PRESSURE FEED

Servo supply pressure delivers the force needed to change the position of the swash plate in variable displacement and pressure regulated motors. For equipment options for Series 02 motors please refer to the model code.

For HMV-02 variable motors
Internal supply. Purge circuit

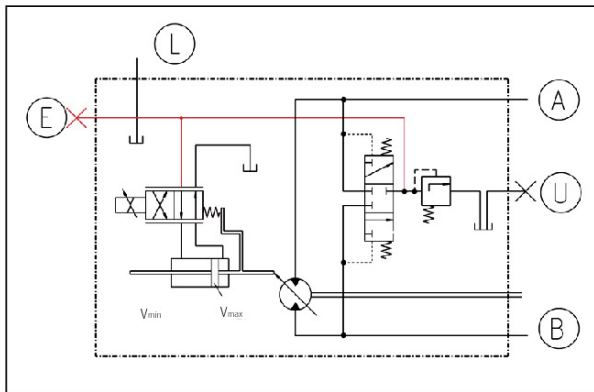

External supply. Purge circuit

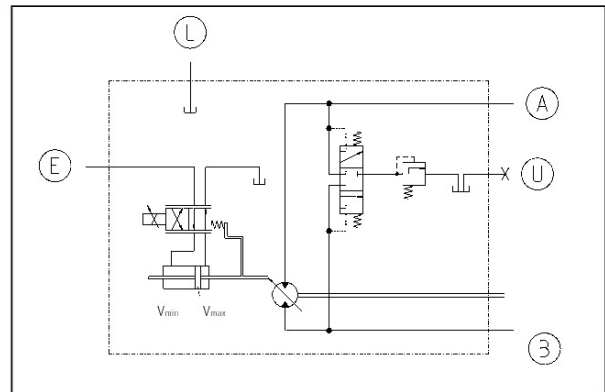

For HMR-02 Regulating motors
Internal supply. High pressure circuit

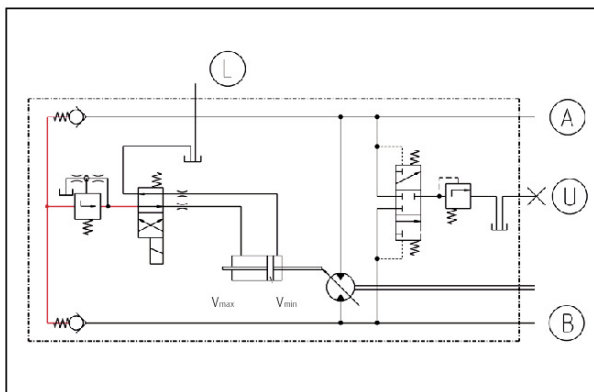

- A, B Work ports
- L, U Case drain / vent connections
- E Make-up connection

FUNCTIONS. CROSSLINE RELIEF (SECONDARY) PROTECTION

The secondary valves (crossline relief valves) protect the system from pressure overload by using two interlinked pressure relief valves (combined with check valves). It is recommended for applications where this protective function is not provided by other means (e.g. through primary protection at the pump or LS valves). The secondary protection includes a make up function. It prevents cavitation and is required in an open loop circuit if the motor requires more oil than is supplied. For special situations like in the swing gear drive the installation of controllable secondary valves is recommended. For equipment options for Series 02 motors please refer to the model code.

Without crossline relief valve

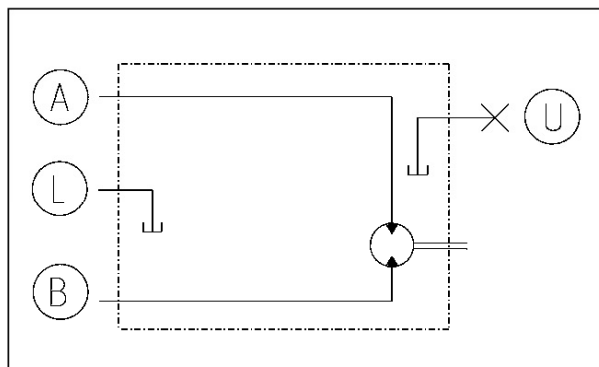

With crossline relief valve protection

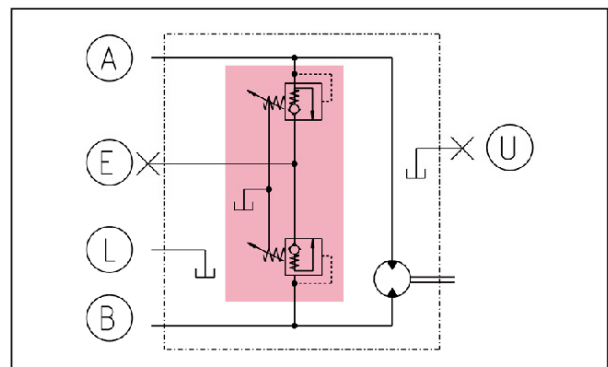

With dual pressure crossline relief valve protection

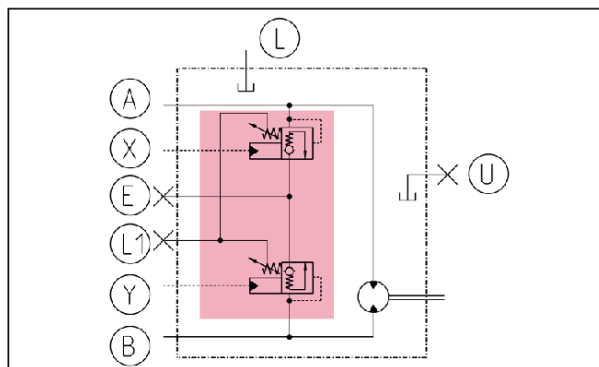

- A, B Work ports
- L, L1, U Case drain/vent connections
- X, Y Control connection for dual pressure crossline relief valve
- E Make up connection

FUNCTIONS. SIGNAL SELECTION FOR PRESSURE REGULATOR

Pressure regulated motors shift to maximum displacement at high operating pressure, irrespective of which side is under pressure. In propel drives this can have undesirable effects. For example, if the motor shifts to maximum displacement during the transition phase from straight travel with low system pressure to overrun (deceleration, downhill travel) with high pressure on the reverse side, an extremely strong vehicle braking effect will occur. The signal selection for pressure regulator prevents the regulator being subjected to this braking pressure and, therefore, ensures that the motor remains at minimum displacement. For equipment options for Series 02 motors please refer to the model code.

Without signal selection for pressure regulator

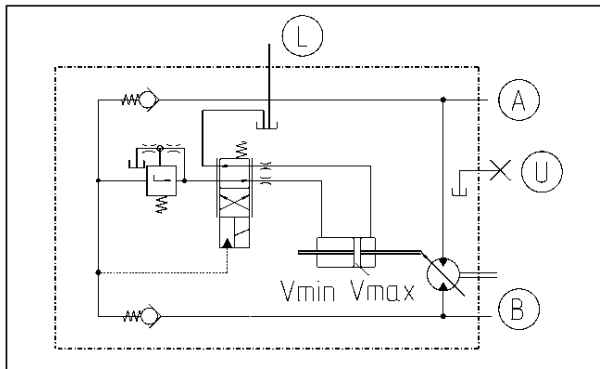

With signal selection for pressure regulator

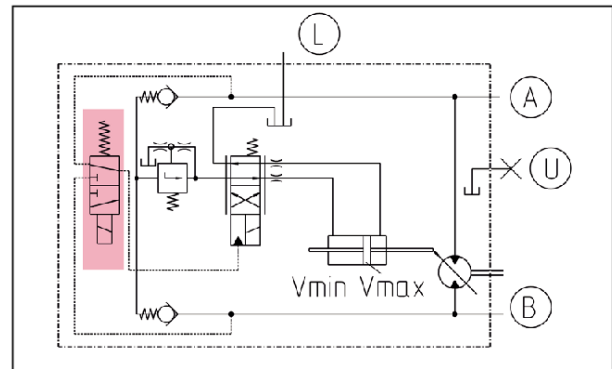

FUNCTIONS. COUNTERBALANCE VALVE

The counterbalance (brake) valve prevents the motor over speeding during an over-run situation. To achieve this, the motor return flow is automatically and continuously metered such that it always matches the input flow. Different braking responses are possible. The integrated make-up function simultaneously prevents cavitation. A purge and case flushing function is also integrated. Counterbalance (brake) valves are typically used for drive systems in open loop circuits. The function of the high pressure relief valves can be integrated in the counterbalance valves. Further types of counterbalance valves are shown in section "Dimensions. HMR-02".

With counterbalance (brake) valve, here: axial attachment

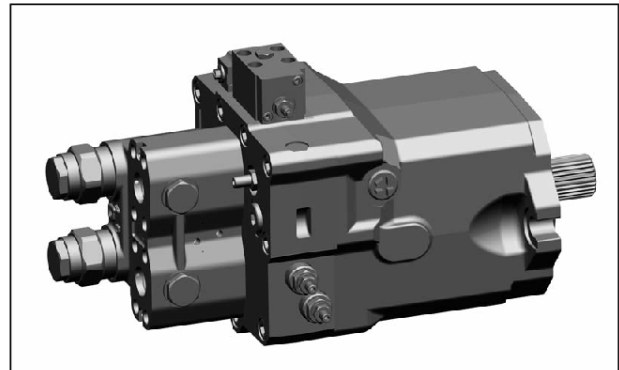
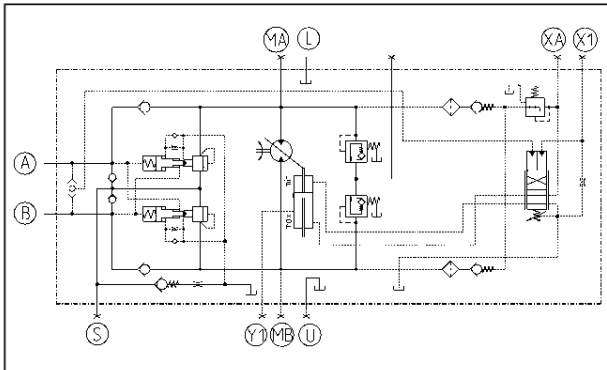

Dimensions

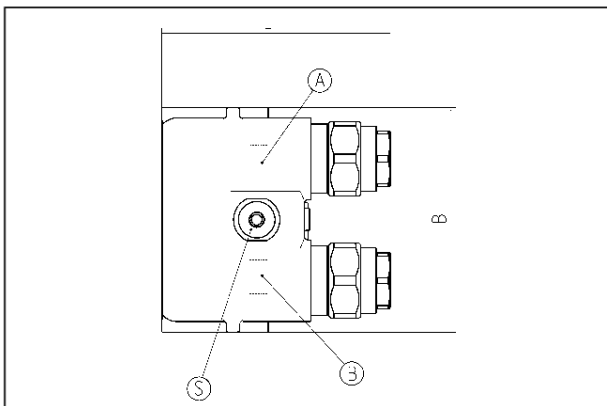

Brake valve	1"	1 ¼"
Length L	168.5	168.5
Width B	165.7	195
Height	136.6	143

FUNCTIONS. SPEED SENSOR

Speed sensors electronically register the motor speed and send an associated input signal to electronic drive controls. Examples are shown below.

Without speed sensor

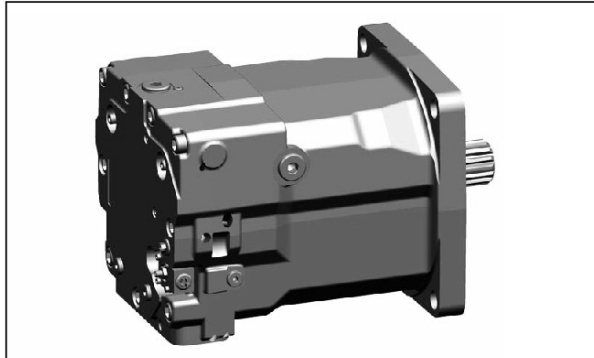

With speed sensor

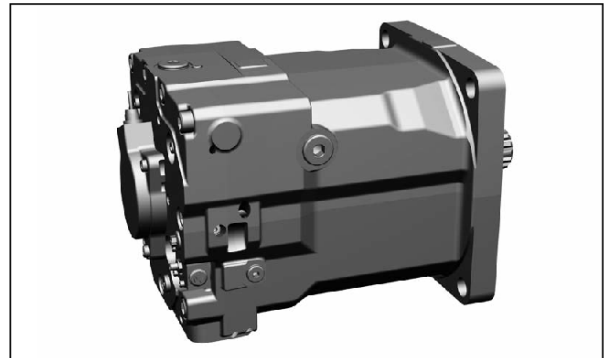
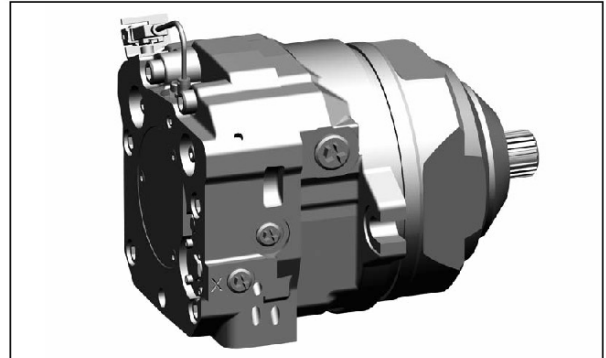

MOTOR TYPES.

Based on the respective system requirements, Linde Hydraulics offers fixed displacement, variable displacement and regulating motors with high starting torque for open and closed loop operation. Optional auxiliary functions, zero displacement capacity and PTO through-shaft enable higher machine design flexibility and increase the efficiency of the travel drive. The motors are optionally controlled electrically, hydraulically or pneumatically.

Function overview

Motor type	Control/function	Product name
Fixed displacement motor		HMF-02
	with swing drive function	HMF-02 P
	displacement adjustable	HMA-02
Regulating motor	V_{max} pneumatic	HMR-02
	V_{max} hydraulic, low pressure	HMR-02
	V_{max} hydraulic, high pressure	HMR-02
	V_{max} electric	HMR-02
Variable displacement motor	stepless variable control, hydraulic	HMV-02 H1
	stepless variable control, electric	HMV-02 E1, E4, E6
	two position control (flip-flop), hydraulic	HMV-02 H2
	two position control (flip-flop), electric	HMV-02 E2
	hydraulic stepless variable control w/ pressure override and electric pressure selection	HMV-02 EH1P HMV-02 EH1P CA

HMV-02 H

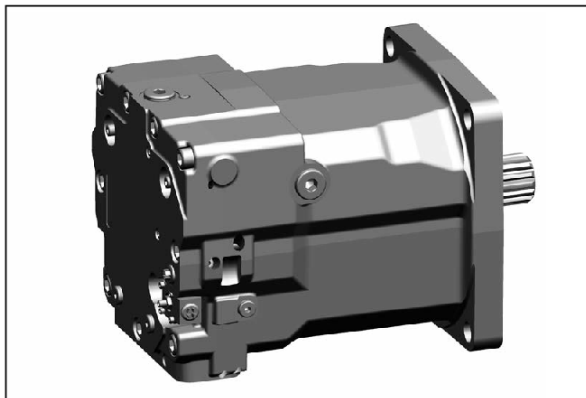

HMV-02 E

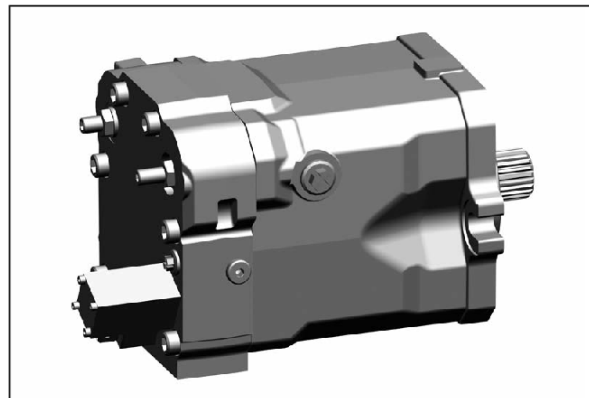

HMV-02 EH1P

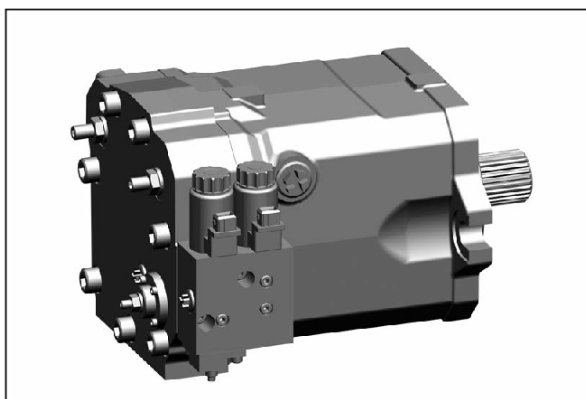

HMV-02 PTO

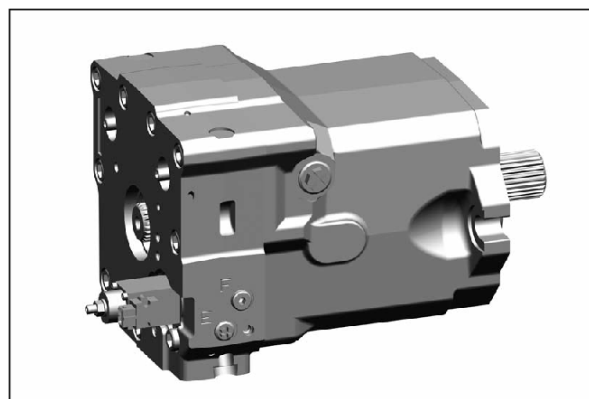

MOTOR TYPES.

HMV D-02

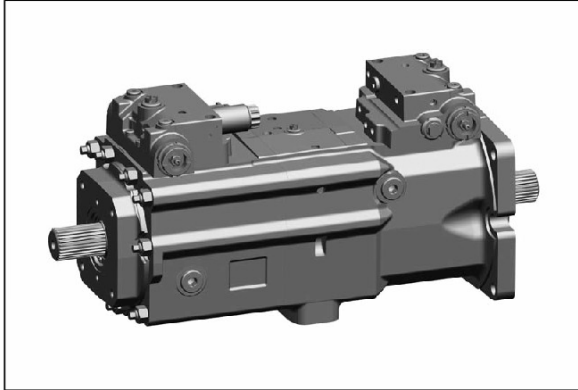

HMV T-02

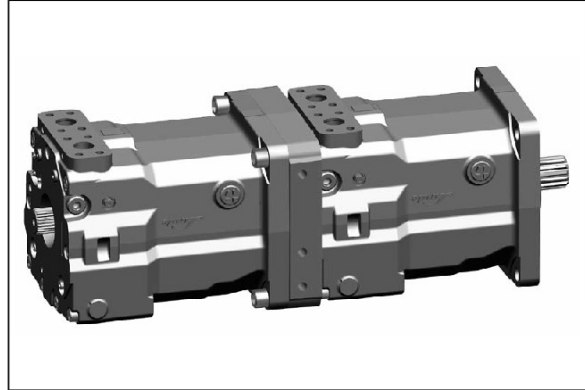

HMR-02

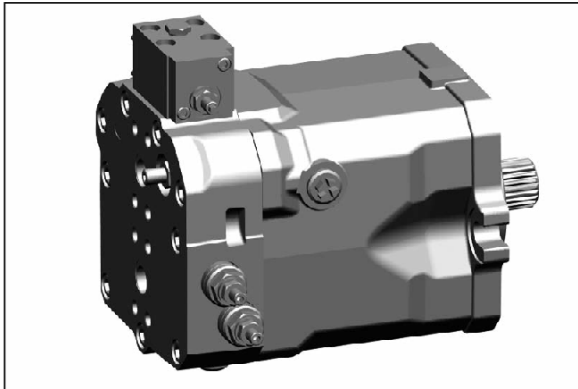

HMF-02

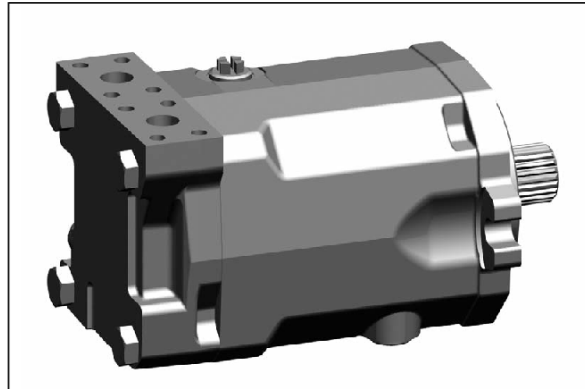

HMF-02 P

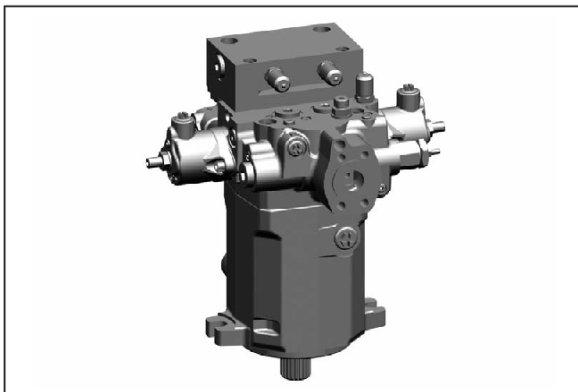

HMA-02

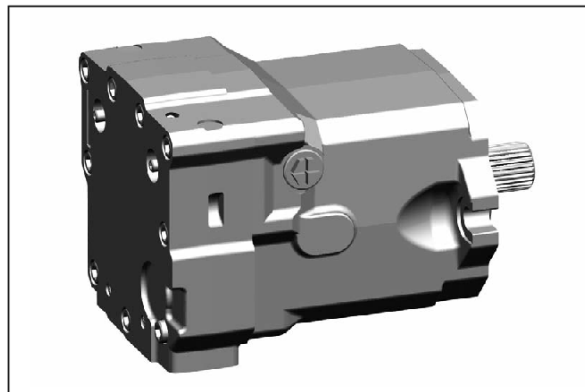

MOTOR TYPES. HMV-02

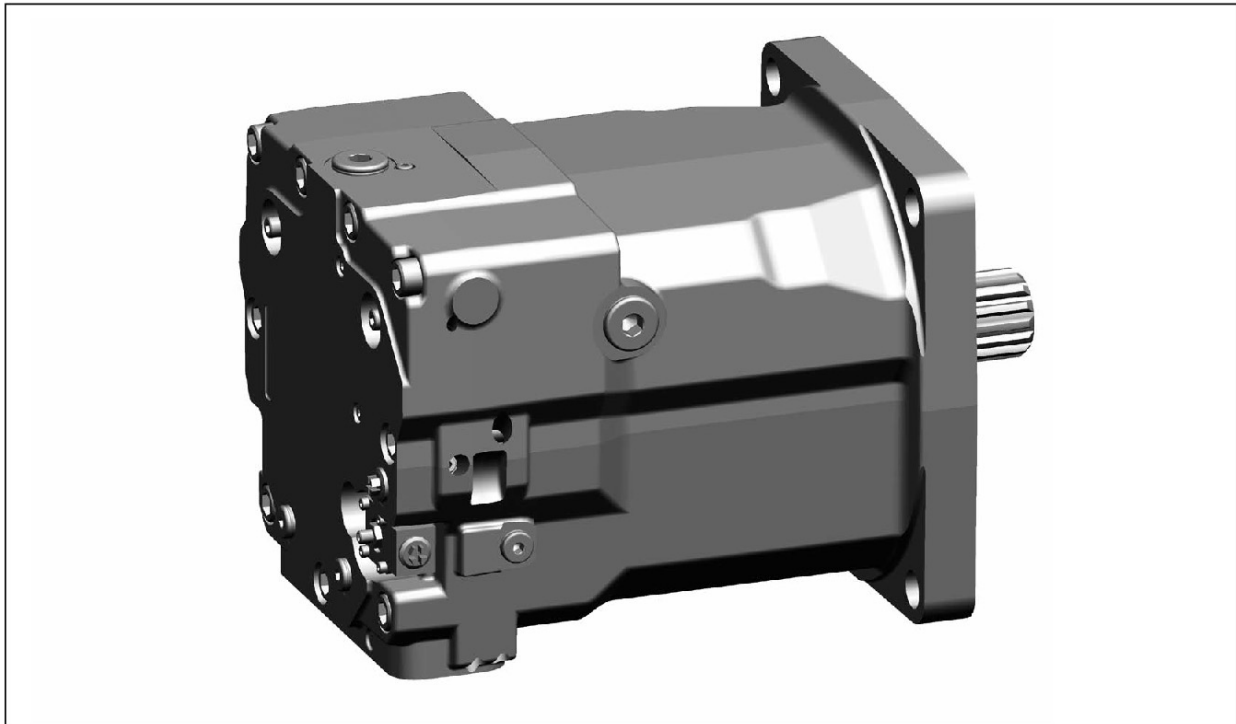

Further features

- >> stepless or two position control
- >> electric or hydraulic control
- >> override pressure control possible
- >> signal selection for pressure regulator possible
- >> can be set to 0 cc/rev
- >> double motor available

Product benefits

- >> smooth low-speed operation
- >> high starting torque
- >> wide torque/speed conversion range
- >> highly dynamic response characteristics
- >> compact design
- >> high power density
- >> high reliability
- >> long service life
- >> simplified drive line

MOTOR TYPES. HMV-02 H1 AND E1 STEPLESS

Motors with stepless variable control are suitable for open and closed loop circuit. Without control signal they shift to maximum displacement V_{max} . Displacement control is hydraulic or via an electric proportional control signal. Servo pressure supply can be applied internally or externally, see section "Functions. Servo pressure supply". The following data are independent of the nominal motor size.

Stepless variable control features

External servo pressure supply	Minimum tripping	bar	20		
	Maximum permissible	bar	40		
Hydraulic control if $V_{max, eff} > V_{min, nominal}$, the resolution is lower	Control range	bar	$\Delta=6$		
	Control begin	bar	7, 8, 9 or 9.5		
	Maximum permissible pressure	bar	40		
Electric control	Connector type		DIN EN 175301-803, Deutsch, AMP Junior Timer, (7-pin, Cod.1)		
	Rated voltage = max. continuous voltage	V	12	24	
	Voltage type		DC voltage		
	Power input	W	15.6		
	Rated current = max. continuous current	mA	1300		
	Control current	Swash begin	mA	450	225
		Swash end	mA	1200	600
	Relative duty cycle	%	100		
	Protection class		IP54 (DIN), IP67 (Deutsch), IP 6K6K (AMP)		
	Control types	Digital control via Pulse Width Modulation PWM		100 Hz rectangle, Pulse duty ratio variable over control range	
Analog			Direct current with dither overlay (dither frequency nom. 35 Hz, duty cycle 1:1)		
Minimum response time with standard orifice with 20 bar servo pressure		s	0.5 - 1		

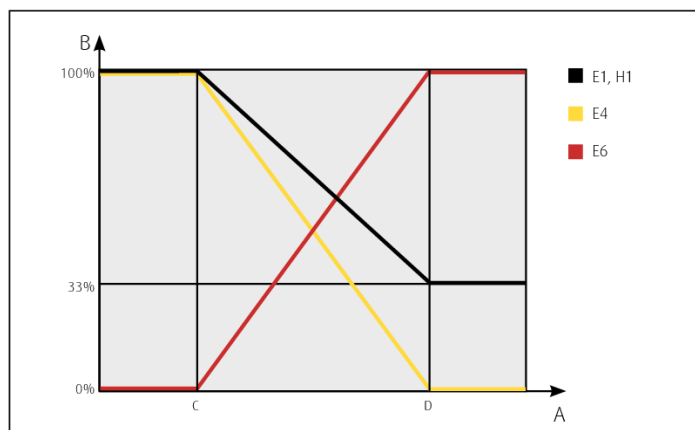

- A Control pressure /current
- B Motor displacement
- C Swash begin
- D Swash end
- Characteristic E1, H1 control
- Characteristic E4 control
- Characteristic E6 control



MOTOR TYPES. HMV-02 H2 AND E2 TWO POSITION

Two position motors are suitable for open and closed loop operation. Without control signal they are set to maximum displacement V_{max} . Adjustment between V_{min} and V_{max} is smooth and with short response time. The required switching signal can optionally be hydraulic or electric, the servo pressure supply internal or external, see section Functions. Servo pressure supply. The following data are independent of the rated motor size.

Two position control features

External servo pressure supply	Minimum tripping	bar	20	
	Maximum permissible tripping	bar	40	
Hydraulic control	Shifting pressure Minimum tripping	bar	20	
	Shifting pressure Maximum permissible tripping	bar	40	
Electric Control	Connector type		DIN EN 175301-803, Deutsch, AMP Junior Timer, (2-pin, Cod.2)	
	Rated voltage = max. continuous voltage	V	12	24
	Voltage type		DC voltage	
	Power input (cold)	W	≤ 26	
	Relative duty cycle	%	100	
	Protection class		IP54 (DIN), IP67 (Deutsch), IP 6K6K (AMP)	
Minimum response time with standard orifice with 70 bar servo pressure		s	0.5 - 1	

Two position motor with hydraulic control pressure and external servo supply pressure

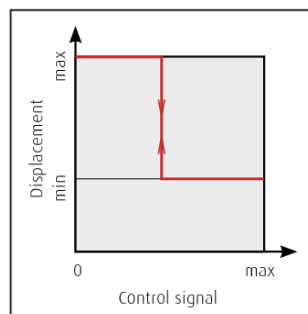
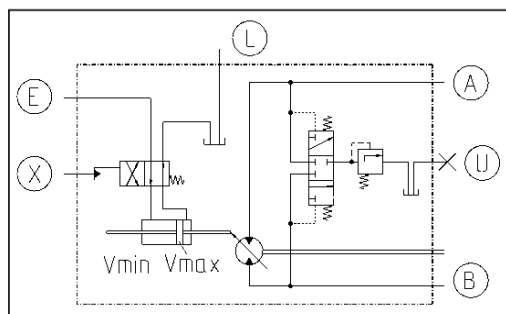

- A,B Work port connections
- L,U Case drain/vent connections
- E Servo supply pressure connection
- X Control connection



MOTOR TYPES. HMV-02 EH1P STEPLESS WITH PRESSURE OVERRIDE

This motor is used primarily for closed loop operation together with speed-dependent hydraulic pump, type HPV-02 CA. Alternatively, with hydraulically or electro-hydraulically pilot-operated drives for which a high pressure regulating function is also required. Without control signal the motor shifts to maximum displacement V_{max} . Stepless variable control to lower displacement is hydraulic, with control pressure generated by the speed dependent pump. The motor is also equipped with a system pressure override which, at a predefined setting, automatically increases its displacement in response to system related torque demand. The following data are independent of the rated motor size.

Features of stepless variable control with pressure override

Hydraulic control signal	Control pressure range	bar	8 to 14
	Maximum premissible pressure	bar	40
Hydraulic pressure override	Regulation begin pressure adjustable, please specify with order	bar	190-260
	Regulation end pressure	bar	5 % above regulation begin pressure
Electric control signal	Electric V_{max} control and signal selection for pressure regulator, see E2 control for technical data		
Minimum response time with standard orifice with 20 bar servo pressure		s	0.5 - 1

Auxiliary functions

- >> Electric V_{max} control, independent of signal pressure, for maximum displacement motor operation
- >> Electric selection of pressure signal for pressure regulator. For details, see "Functions. Signal selection for pressure regulator"

EH1P. Case pressure as reference, «Bleed» regulation

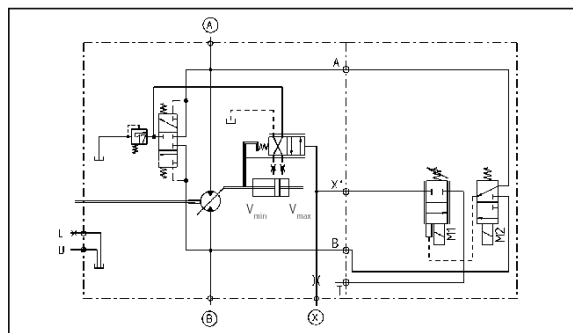

EH1P-CA. Feed pressure as reference, «Non-Bleed» regulation

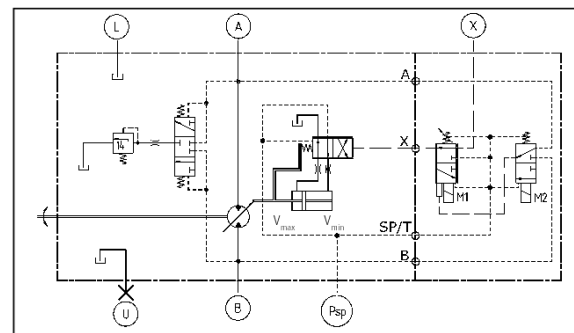

Characteristic EH1P & EH1P-CA

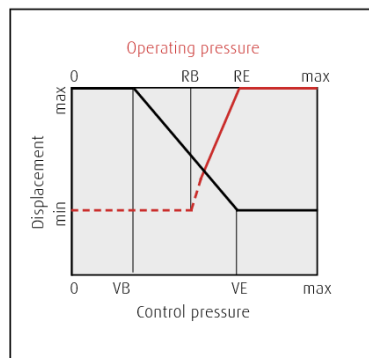

- | | | | |
|----|----------------------------|-----|--|
| VB | Swash begin | A,B | Port connections |
| VE | Swash end | L,U | Case drain / vent connections |
| RB | Start of pressure override | X | Control pressure connections |
| RE | End of pressure override | M1 | Solenoid for maximum displacement override |
| — | Operating pressure | M2 | Solenoid for signal selection for pressure regulator |
| — | Control pressure | | |



MOTOR TYPES. HMV D-02 DOUBLE MOTOR

The double motor consists of two Series 02 variable motors arranged back-to-back. In addition to a wide torque/speed conversion range it offers the option of direct installation in the drive line, since one or two shaft ends are optionally available for torque output. Noise emission and fuel consumption are reduced because no transfer gearbox is required. At the same time the overall efficiency increases. The performance comparison diagram shows the required drive capacity for different design variants at four operating points.

HMV D-02

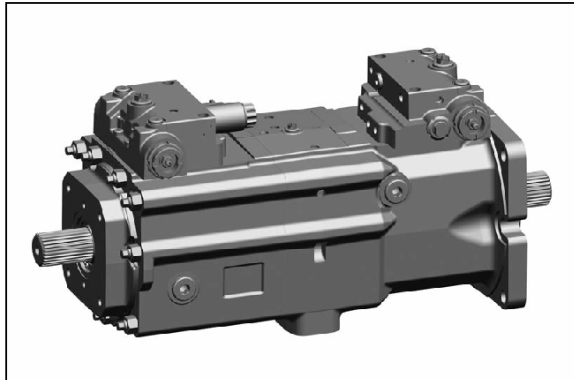

Performance comparison

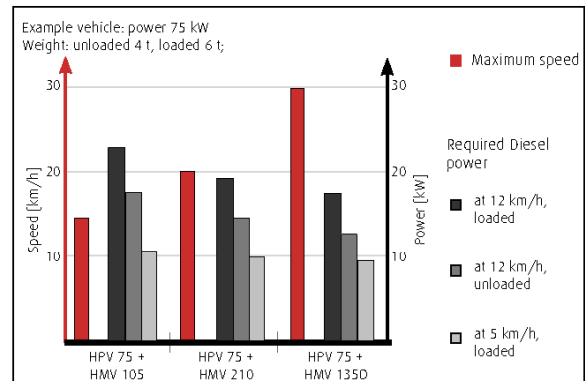

Further features

- >> two HMV-02 arranged back-to-back
- >> connection for high pressure, servo and control pressure for each motor
- >> motor control optionally through one signal or two separate signals
- >> both motors can be set to 0 cc/rev
- >> possible conversion ratio 1:6
- >> optionally two shaft ends for direct installation in the drive line

Product benefits

- >> wide conversion range for stepless acceleration
- >> simplified drive line
- >> high tractive effort and high terminal speed
- >> highly dynamic response characteristics
- >> high starting torque

2-pos. gearbox/conventional transmission

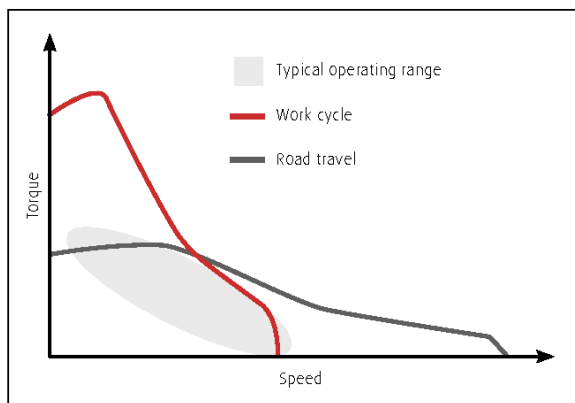

Stepless with double motor

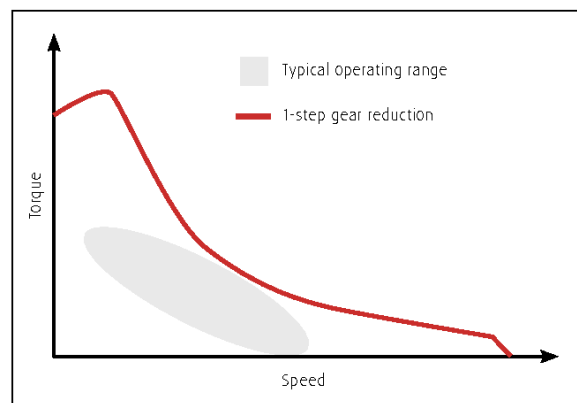

MOTOR TYPES. HMV T-02 TANDEM MOTOR

The tandem motor consists of two HMV-02, arranged face-to-back and connected with a tandem flange. Alike the double motor, the tandem motor can also be integrated directly into the driveline and is available with one or two shaft ends.

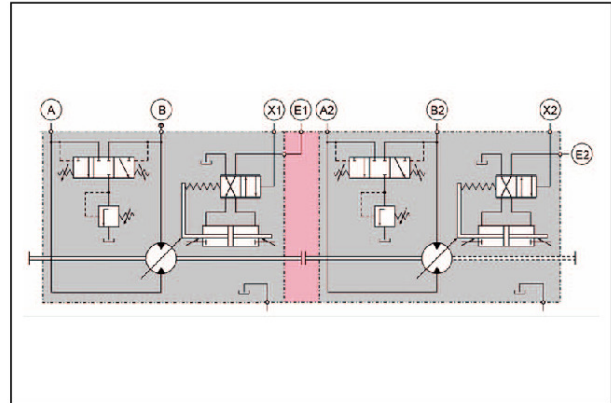
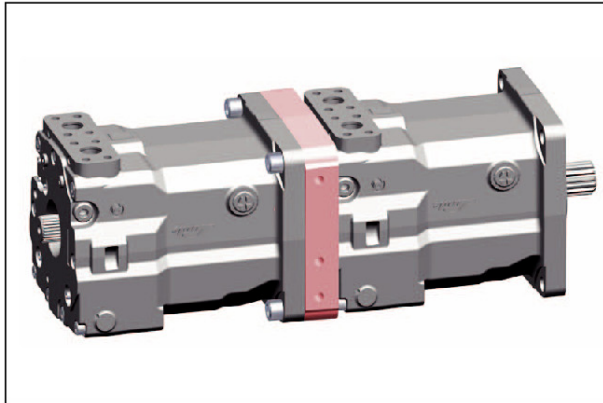

Further features

- >> two HMV, arranged face-to-back
- >> available as HMV 210-02 and 280-02
- >> separate connections for high pressure and feed pressure
- >> individual control
- >> both motors can be set to 0 cc/rev
- >> same mounting flange as single motor

Benefits

- >> doubled torque at same gearbox interface
- >> simple torque increase in existing applications
- >> higher speed as with single motors of the same size and as with bent axis motors
- >> more slender outline as single motors of the same size
- >> direct driveline-integration, no need for gearbox

MOTOR EQUIPMENT. CROSS OVER RELIEF VALVE BLOCK

The cross over relief valve block offers additional high pressure protection for the series 02 motors. It is mounted to the radial high pressure ports. As well as this protective function, the block offers tee connectors for the high pressure connections in order to connect an additional motor to the system without the need for long hoses.

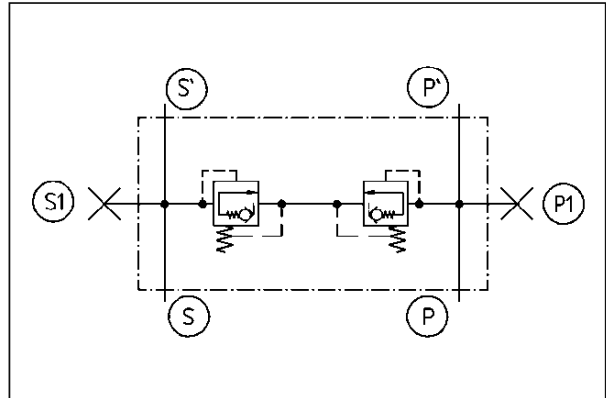
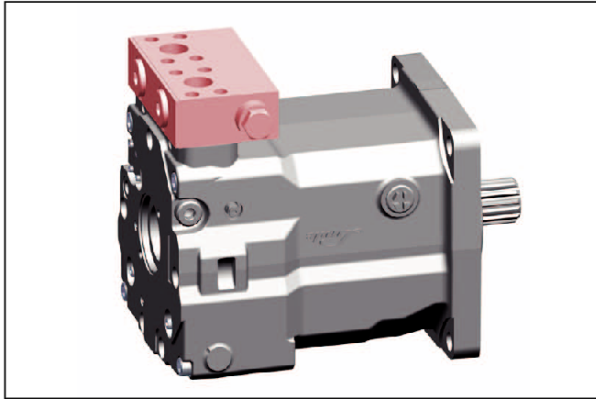

Further features

- >> modular add-on functionality
- >> for radial high-pressure connections
- >> for all HMV/HMR/HMA-02 motors

Benefits

- >> additional high pressure relief in closed circuit application
- >> pressure relief exceeding the pump relief valve capability, for example while breaking hydraulically with high displacement ratio HMV V_{min}/V_{max}
- >> connection of a second motor with minimized hydraulic hose length, for example tandem motors

MOTOR TYPES. HMR-02

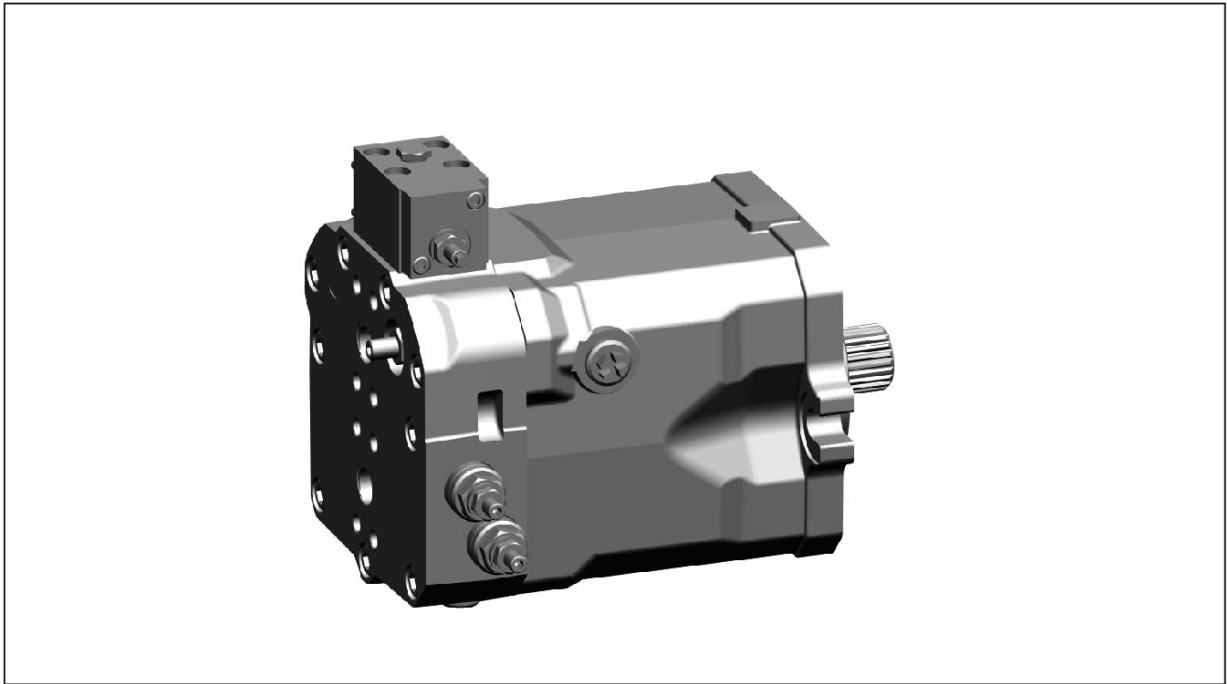

Further features

- >> optionally with purge valve for circuit and case flushing in closed loop circuit
- >> system pressure regulation, no external control lines required
- >> signal selection for pressure regulator for closed loop circuit
- >> counterbalance (brake) valve CBV optional

Product benefits

- >> smooth low-speed operation
- >> high starting torque
- >> wide conversion range
- >> compact design
- >> high power density
- >> high reliability
- >> long service life
- >> highly dynamic response characteristics
- >> simplified drive line

MOTOR TYPES. HMR-02

Linde regulating motors are suitable for open and closed loop operation. They are high-pressure regulated and shift to minimum displacement V_{min} at system pressures below the regulation begin point. When the defined high pressure regulation set point is reached, the motor smoothly increases displacement to match the torque required by the system.

The following data are independent of the rated motor size.

Typical equipment options

- >> Open loop circuit. Secondary (crossline relief) valves or counterbalance (brake) valves
- >> Closed loop circuit. Electric signal selection for pressure regulator

Regulating motor features

Hydraulic regulation	Regulation begin pressure adjustable, please specify with the order	bar	190 to 260	
	Regulation end pressure	bar	5% above regulation begin pressure	
Pneumatic V_{max} override control	Shift pressure min/max	bar	4 to 8	
Hydraulic V_{max} override control	Shift pressure min/max Low pressure	bar	20 to 30	
	Shift pressure min/max High pressure	bar	30 to 420	
Electronic control signal	Connector type		DIN EN 175301-803, Deutsch, AMP Junior Timer (2-pin, Cod. 2)	
	Rated voltage = max. continuous voltage	V	12	24
	Voltage type		DC Voltage	
	Power input (cold)	W	≤ 26	
	Relative duty cycle	%	100	
	Protection class		IP54 (DIN), IP67 (Deutsch), IP 6K6K (AMP)	
Minimum response time with standard orifice with 20 bar servo pressure		s	0.3 - 0.6	

Regulating motor characteristic

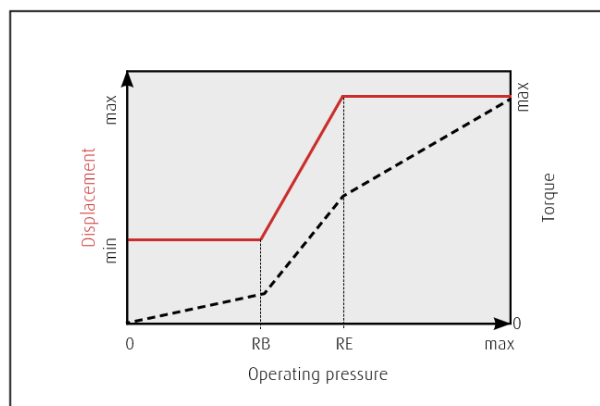

- RB Regulation begin
- RE Regulation end
- Displacement
- - - Torque

MOTOR TYPES. HMR WITH V_{max} OVERRIDE CONTROL

The additional V_{max} control enables fixed displacement motor operation independent of the control pressure.

Regulating motor with hydraulic V_{max} override control

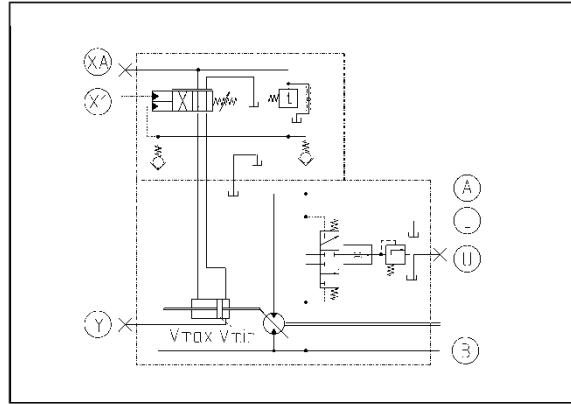
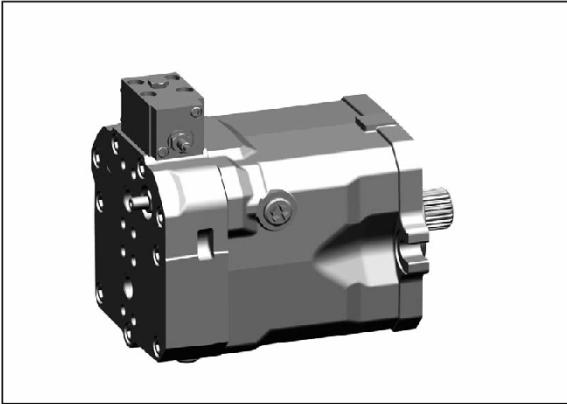

Regulating motor with pneumatic V_{max} override control

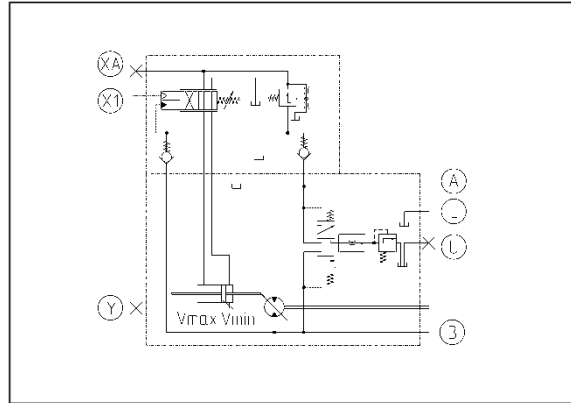
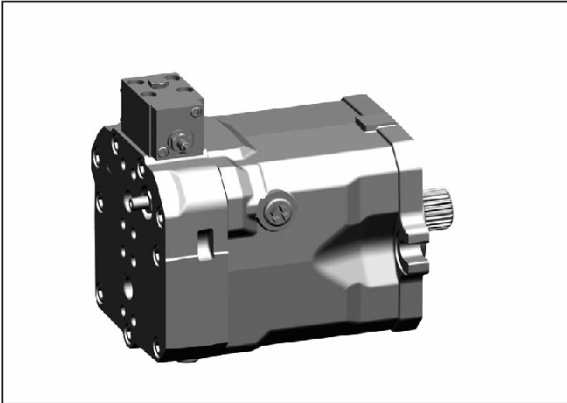

HMR-02 with electric V_{max} override control and signal selection for pressure regulator

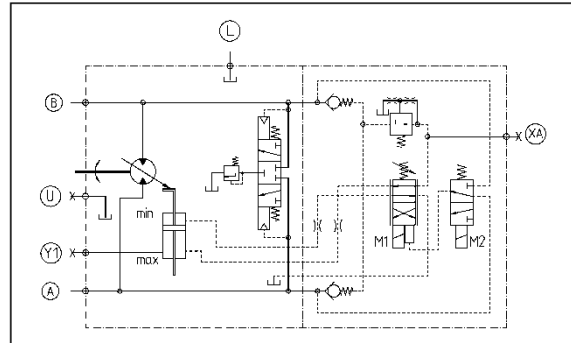
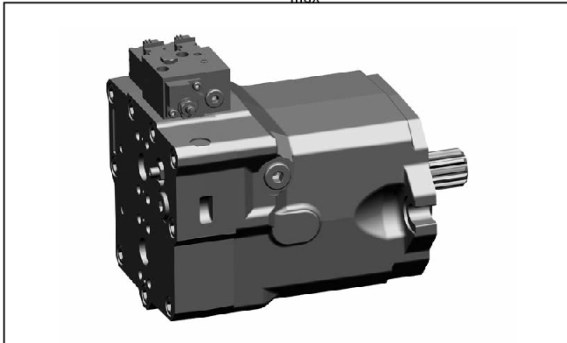

HMR-02 with electric signal selection for pressure regulator

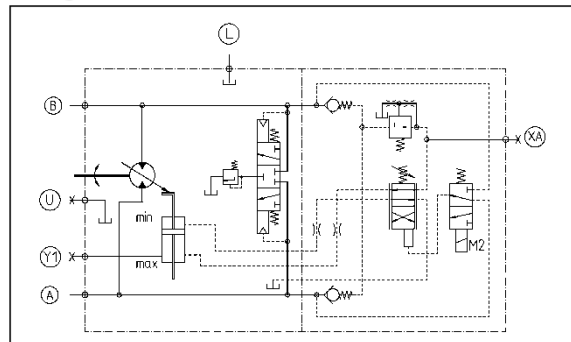
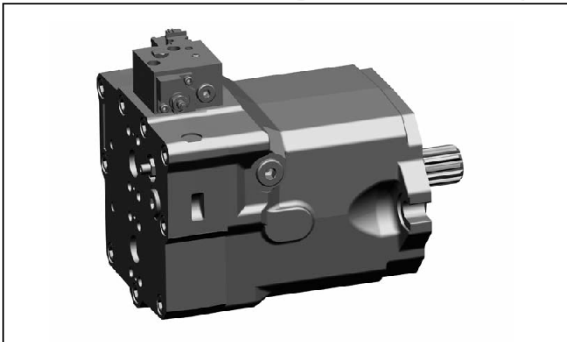

MOTOR TYPES. HMF-02

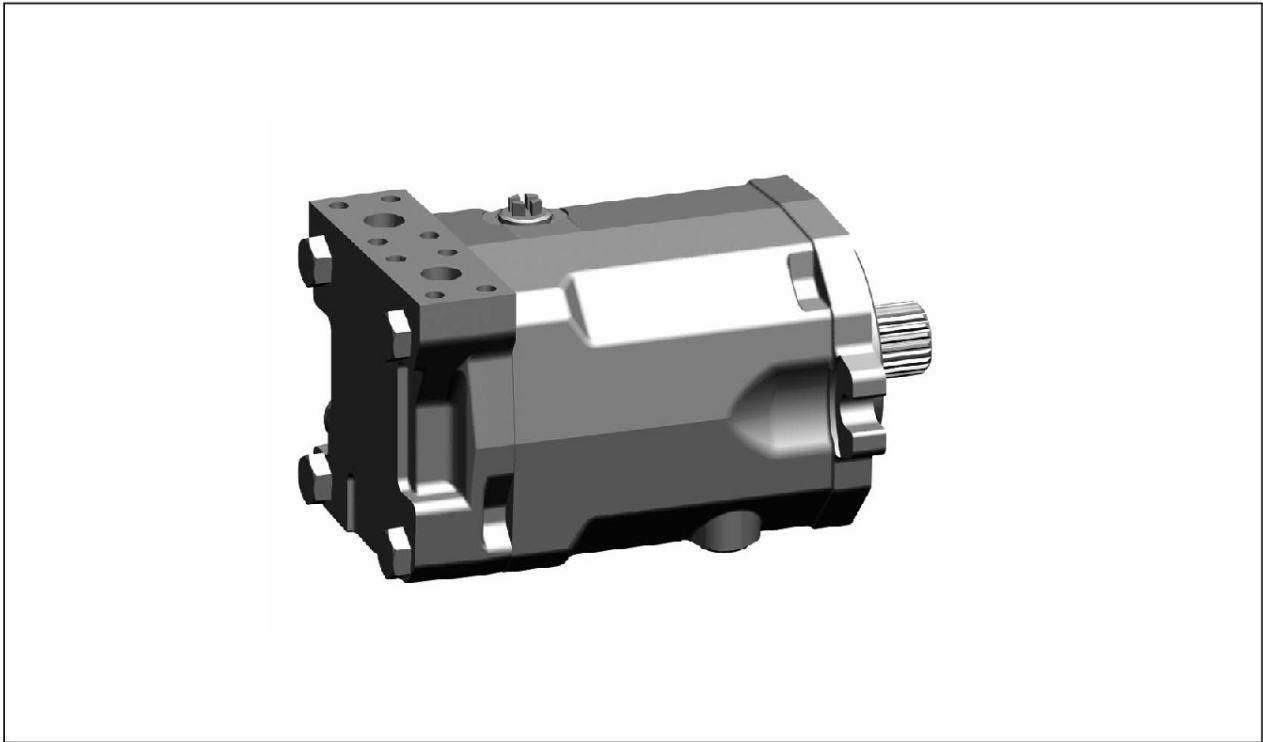

Further features

- >> optimised start-up and low-speed characteristics
- >> optionally with purge valves for purge and case flushing
- >> fixed and dual setting secondary valves optional

Product benefits

- >> smooth low-speed operation
- >> high starting torque
- >> compact design
- >> high power density
- >> high reliability
- >> long service life

MOTOR TYPES. HMF-02

The HMF-02 motor is a high-pressure fixed displacement motor for open and closed loop operation. Secondary valves enable customised definition of soft motor start-up and slowdown. With dual setting secondary valves the maximum acceleration and braking torque is additionally available. The settings and shifting ranges can be adjusted according to project-specific requirements, see sections “Functions. Crossline (secondary) protection” and “HMF-02 P”.

Fixed displacement motor HMF-02

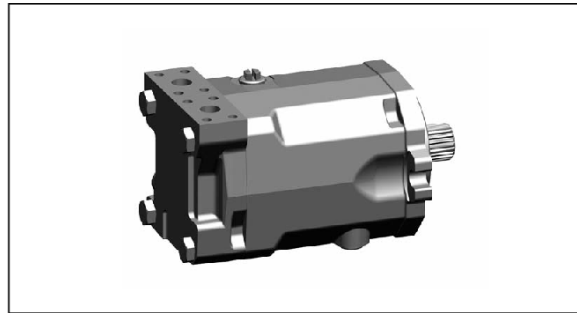
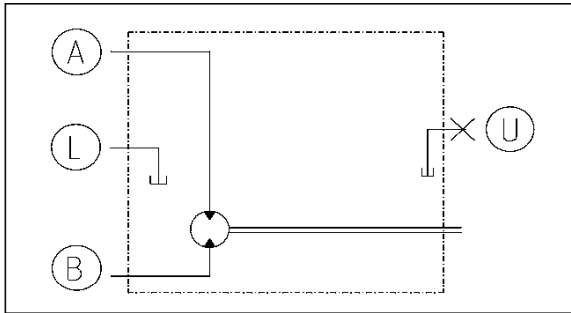

Fixed displacement motor with crossline relief valves fixed setting

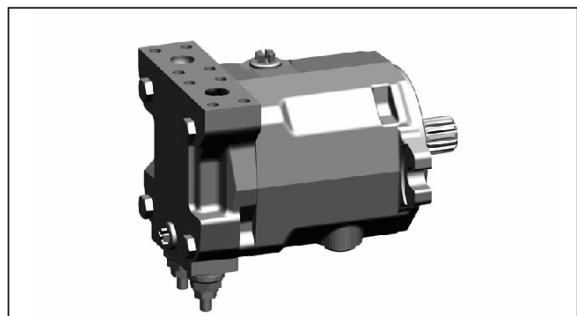
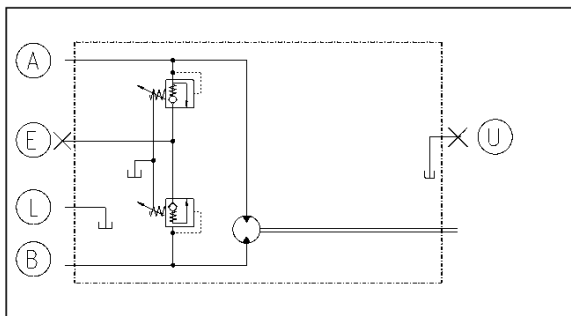

Motor with dual pressure crossline relief valves

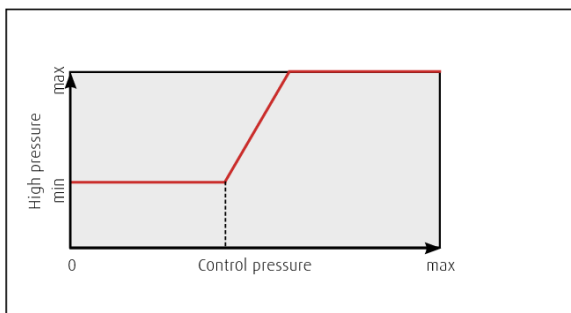
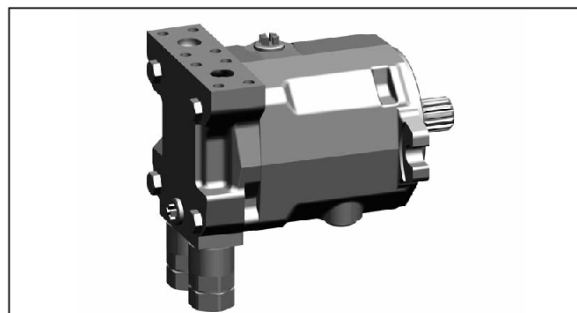
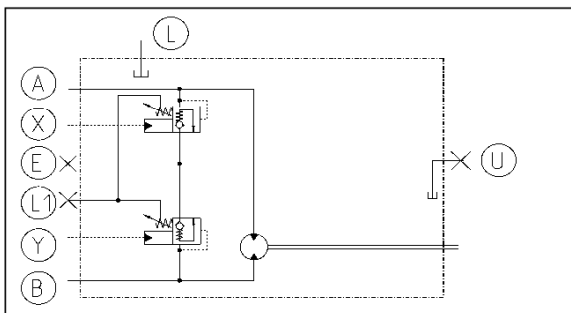

- A, B Work ports
- L, L1, U Case drain / vent connections
- X, Y Control connections for dual pressure crossline relief valve
- E Make up connection



MOTOR TYPES. HMF-02 P

The HMF-02 motor is a high-pressure fixed displacement motor for open loop operation. With integrated LS directional control valve and TC torque control it combines the benefits of the Series 02 with all auxiliary functions typically required for application in swing and winch drives. The HMF-02 P is available in the rated sizes 35, 55, 75 and 105. Differing from the standard HMF, the nominal pressure is 280 bar, the peak pressure is 300 bar.

HMF-02 P with integrated swing function

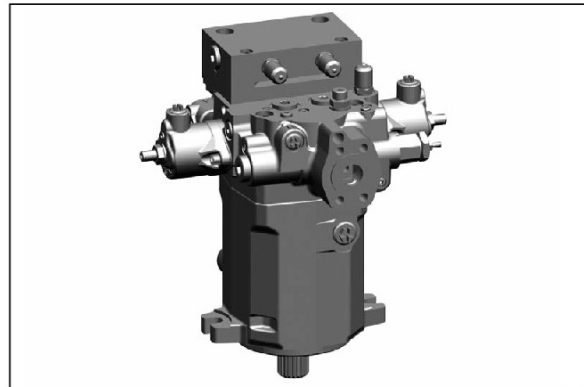
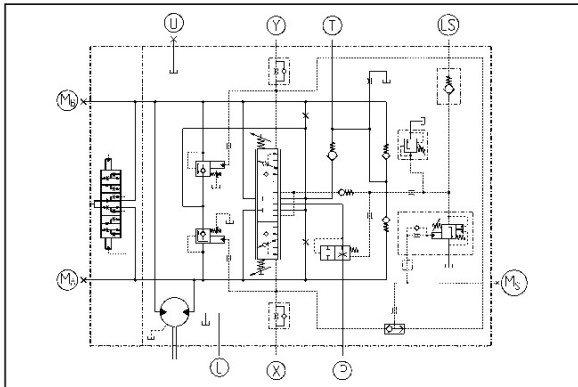

Features

- >> directional control valve function
- >> torque control function
- >> HP valves with controllable characteristic curve
- >> priority function
- >> secondary protection combined with make-up function
- >> purge and case flushing function
- >> anti reaction valve

Product benefits

- >> smooth low-speed operation
- >> high starting torque
- >> torque and speed control
- >> controllable counter-rotation
- >> compact design
- >> high power density
- >> high reliability
- >> long service life

TC function

For powerful and dynamic application in swing drives the TC function enables control pressure-dependent acceleration. Once the maximum rotating speed is reached, torque control is superimposed and pressure level is reduced for energy-saving operation. If the control valve is reset to the neutral position, no additional control signal is generated and the rotary motion slows down uniformly. Active counter-rotation is possible with controllable secondary valves. A counteractive control signal is generated, and the rotary motion is decelerated along the characteristic counter-rotation pressure curve.

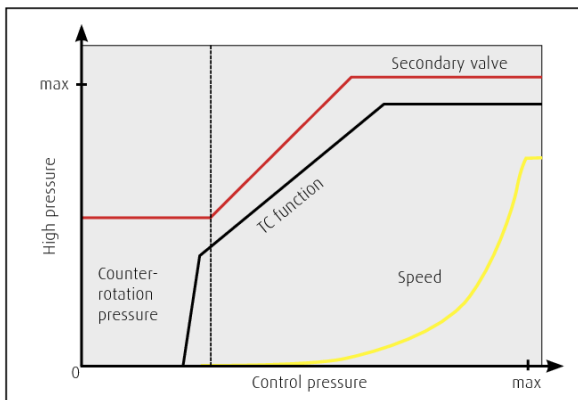

- P, T Work port connections
- L, U Case drain / vent connections
- LS LS-pressure connection
- M Gauge ports



MOTOR TYPES. HMA-02

The HMA-02 motor is a high-pressure motor with adjustable displacement for open and closed loop operation. For application which requires dependent on the situation a reduced or increased displacement, the HMA-02 offers the expected flexibility. Since the displacement can be adjusted on request stepless at a screw. For a well-adjusted torque.

HMA-02 the adjustable fixed displacement motor

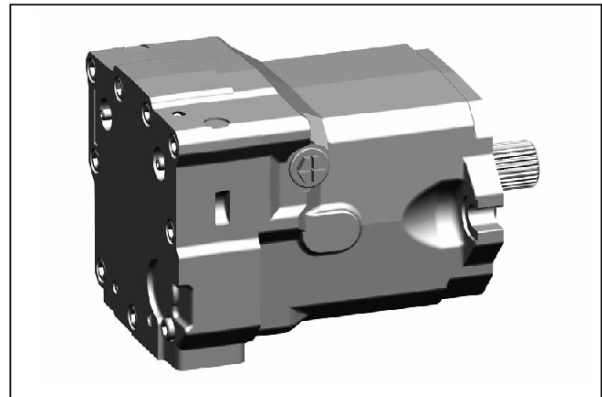
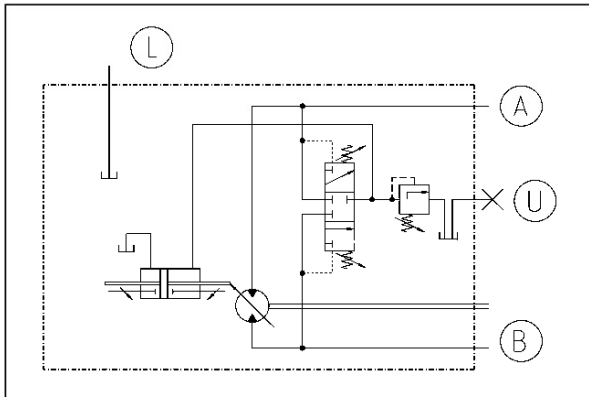

- A, B Work port connections
L, U Case drain / vent connections

DIMENSIONS. HMR-02

Rated size	55	75	105	135	165	210	280
D1 [mm]	127			152.4		165.1	
B1 [mm]	181			228.6		224.5	
B2 [mm]	208			258		269	
B3 [mm]	86	95	96	108	125	134	156
B4 [mm]	95		96	108	125	134	156
B5 [mm]	86	95	96	108	125	*	*
B6 [mm]	85	95	96	108	125	*	*
B7 [mm] with electric override control	-	180	181	193	210	*	*
B8 [mm] with electric override control	-	180	181	193	210	*	*
H1 [mm]	80	86	91	98	98	135	
H2 [mm]	83	93	99	103	98	135	
H3 [mm]	84	93	95	108	120	134	151.5
H4 [mm]	90	105	106	114	132	133	152.5
H5 [mm]	84	93	96	107	118	*	*
H6 [mm]	90	105		114	132	*	*
H7 [mm] with electric override control	-	88			102.5	*	*
H8 [mm] with electric override control	-	92			77.5	*	*
L1 [mm]	41	56		75			
L2 [mm]	212	226	247	270	314	336	381
L3 [mm] control	hydraulic control	33			5	5	8
	electric control	75			58	55	59
L4 [mm]	217	231	252	275	305	*	*
L5 [mm] control	hydraulic control	18			5	*	*
	electric control	70			58	*	*
L6 [mm] with electric override control	-	33			32.5	*	*
L7 [mm] with electric override control	-	28			32.5	*	*
L8 [mm] with electric override control	-	80			80.5	*	*
L, U	M22x1.5			M27x2		M33x2	
E Port for external servo pressure supply	M14x1.5						
X Port for hydraulic control	M14x1.5						
M, M1 Solenoid for electric control	see section Motor types. HMV-02 stepless						
M2 Solenoid for signal selection for pressure regulator	see section Motor types. HMV-02 stepless						

*) Product design on demand

Metric connection thread according to ISO 6149-1

Locking thread for the SAE high pressure-connections, metric according to ISO 261
Hexagon socket head cap screws according to ISO 4762

Further threads, dimensions and versions with speed sensor are available on request



DIMENSIONS. HMR-02

Radial high pressure-connections

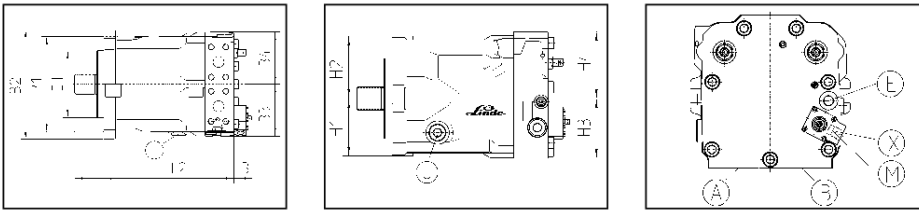

Axial high pressure-connections

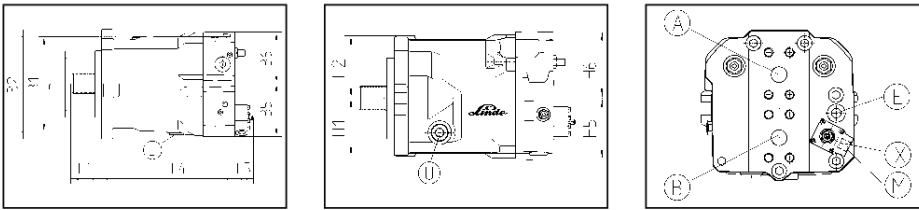

HMV-02 with electric override control

Radial high pressure-connections

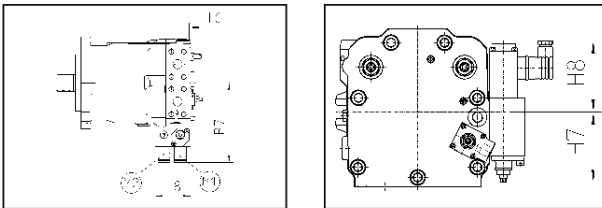

Axial high pressure-connections

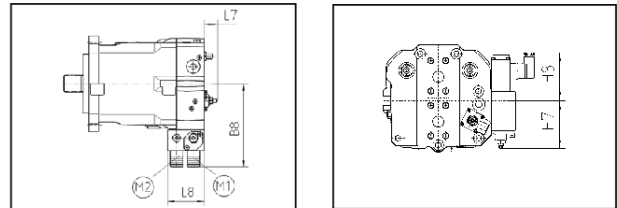

DIMENSIONS. HMR-02

Rated size	75	105	135	165	210	280	
D1 [mm]	127		152.4		165.1	*	
B1 [mm]	181		228.6		224.5	*	
B2 [mm]	208		256		269	*	
B3 [mm] sec. relief valve	without	95	99	108	-	134	*
	with	135	136	140	-	134	*
B4 [mm] sec. relief valve	without	95	105	108	-	134	*
	with	12	105	114	-	134	*
B5 [mm] sec. relief valve	without	95	99	108		*	*
	with	135	139	141	148	*	*
B6 [mm]	102	105	114	125	*	*	
B7 [mm]	pneumatic	74			-	*	*
	hydraulic	62			46	*	*
B8 [mm]	78				*	*	
B9 [mm]	103				108	*	
B10 [mm]	89			169	97.5	*	
B11 [mm]	130			107	97.5	*	
H1 [mm]	86	91	96	98	135.5	*	
H2 [mm]	93	99	100	105	135.5	*	
H3 [mm]	93	98	108	-	134	*	
H4 [mm]	102		110	-	133.5	*	
H5 [mm]	56					*	
H6 [mm]	91	96	107	118	134	*	
H7 [mm]	102	107	109	125	133.5	*	
H8 [mm]	81					*	
H9 [mm]	85			102	168.5	*	
L1 [mm]	56		75			*	
L2 [mm]	229	247	270	-	336	*	
L3 [mm]	231	252	275	304	-	*	
L4 [mm]	53					*	
L5 [mm] regulator with electric maximum displacement override and signal selection for pressure regulator	80					*	
L6 [mm]	127			120	143	*	
L, U	M22x1.5			M27x2	M27x2	*	
X1 port for hyd./pneum. max. displ. override	M14x1.5				M14x1.5	*	
M1 solenoid for electric maximum displacement override	see section Motor types. HMR-02						
M2 solenoid for signal selection for pressure regulator	see section Motor types. HMR-02						

*) Product design on demand

Metric connection thread according to ISO 6149-1

Locking thread for the SAE high pressure-connections, metric according to ISO 261

Hexagon socket head cap screws according to ISO 4762

Further threads, dimensions and versions with speed sensor are available on request



DIMENSIONS. HMR-02

Radial high pressure-connections

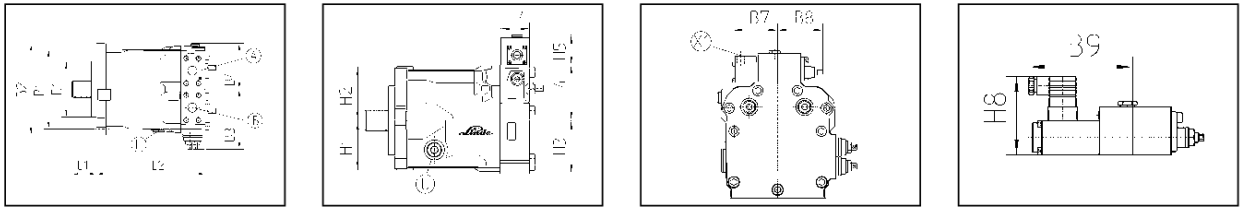

Axial high pressure-connections

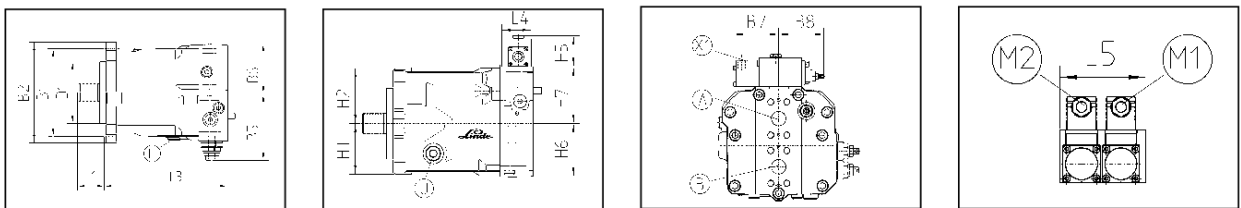

HMR-02 with brake valve. Radial high pressure-connections

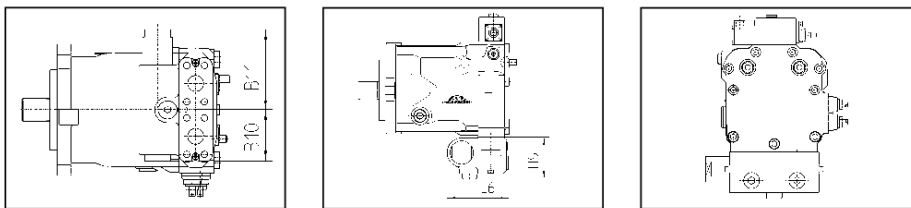

HMR-02 with brake valve. Axial high pressure-connections

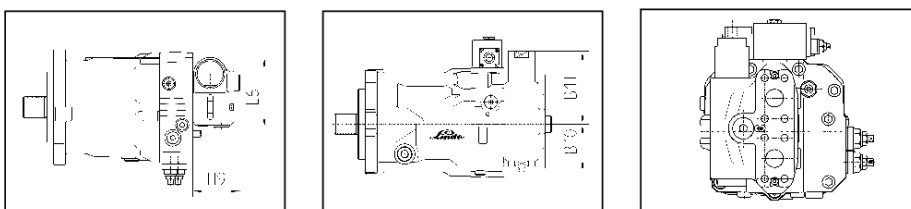

DIMENSIONS. HMF-02

Rated Size	28	35*	50*	75*	105*	135	165 HMA	210 HMA
D1 [mm]	101.6		127			152.4		165.1
B1 [mm]	146		181			228.6		224.5
B2 [mm]	162		200			250	258	269
B3 [mm]	146			166			250	268
B4 [mm]	149			169			250	268
H1 [mm]	61	70	73	82	86	98	135	
H2 [mm]	61	70	73	82	86	98	135	
H3 [mm] crossover relief valves	without	67	72	78	83	89	120	134
	with fixed setting	108	116	119	128	137	-	-
	with dual pressure setting	129	137	140	149	158	-	-
H4 [mm]	69			79	83	88	132	133
H5 [mm]	64	69	75	80	86	132	133	
L1 [mm]	41	56			75			
L2 [mm]	193	202	229	254	277	314	336	
L3 [mm]	191	200	227	252	275	305	336	
L, U	M22x1.5						M27X2	
E connection for anti-cavitation oil supply	M18x1.5			M22x1.5			-	-

*) For dimensions of HMF 35-02 P, 55-02 P, 75-02 P and 105-02 P, please see the installation drawing

Metric connection thread according to ISO 6149-1

Locking thread for the SAE high pressure-connections. Metric according to ISO 261

Hexagon socket head cap screws according to ISO 4762

Further threads are available on request

Radial high pressure-connections

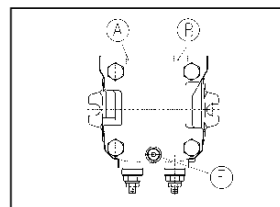
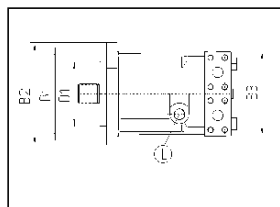
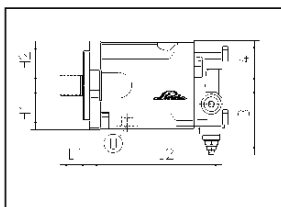

Axial high pressure-connections

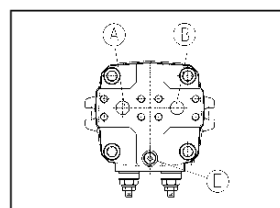
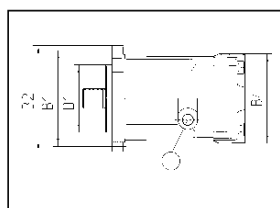
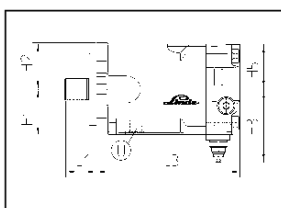

DIMENSIONS.

Connections

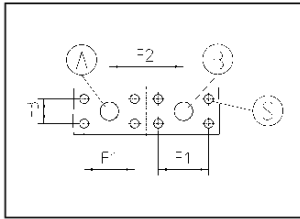

Rated size	28/35	50/55	75	105	135	165	210	280	135D
F1 [mm]	50.8		57.2			66.6		57.2	
F2 [mm]	74		84			102		84	
F3 [mm]	23.8		27.8			31.8		27.8	
A,B [mm]	¾"		1"			1 ¼"		1 ¼"	
S [mm]	M10		M12			M14		M12	

Input flow and drive shaft rotation

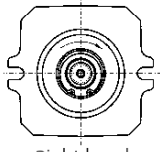
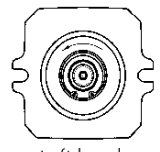
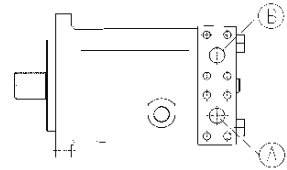
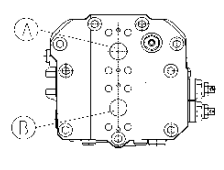
High pressure at port		Shaft output direction of rotation		
			Right hand	Left hand
 	HMV-02	B	A	
	HMV-02 [E6]	A	B	
	HMR-02 HMA-02	B	A	
	HMF-02	A	B	

MODULAR SYSTEM FEATURES.

The Series 02 motors are based on a modular system with the following characteristics. This enables our distribution partners to configure the product according to your requirements. The latest characteristics and available options can be taken from the model code, which is available on our homepage.

- >> V_{min}
- >> Mounting flange
- >> Drive shaft
- >> V_{max} control
- >> Control orifice
- >> Secondary valves
- >> Direction of HP-connections
- >> Purge valve setting
- >> Shuttle valve
- >> Drain port U, L1, L2
- >> Coupling flange
- >> PTO Through-Drive
- >> Port threads
- >> Type of control
- >> Remote control pressure
- >> Start of control
- >> Voltage for E-controls
- >> Connectors for E-controls
- >> Displacement fixing
- >> Speed sensor
- >> Pilot pressure compensation
- >> Surface treatment